

Complex Variables: A Physical Approach

With Applications and MatLab Tutorials

by Steven G. Krantz

To my father, Henry Alfred Krantz: my only true hero.

Table of Contents

Preface	xv
1 Basic Ideas	1
1.1 Complex Arithmetic	1
1.1.1 The Real Numbers	1
1.1.2 The Complex Numbers	1
1.1.3 Complex Conjugate	6
1.2 Algebraic and Geometric Properties	8
1.2.1 Modulus of a Complex Number	8
1.2.2 The Topology of the Complex Plane	10
1.2.3 The Complex Numbers as a Field	12
1.2.4 The Fundamental Theorem of Algebra	15
1.3 The Exponential and Applications	17
1.3.1 The Exponential Function	17
1.3.2 Laws of Exponentiation	19
1.3.3 The Polar Form of a Complex Number	19
1.3.4 Roots of Complex Numbers	22
1.3.5 The Argument of a Complex Number	25
1.3.6 Fundamental Inequalities	25
2 The Relationship of Holomorphic and Harmonic Functions	31
2.1 Holomorphic Functions	31
2.1.1 Continuously Differentiable and C^k Functions	31
2.1.2 The Cauchy-Riemann Equations	32
2.1.3 Derivatives	34
2.1.4 Definition of a Holomorphic Function	36

2.1.5	Examples of Holomorphic Functions	36
2.1.6	The Complex Derivative	38
2.1.7	Alternative Terminology for Holomorphic Functions . .	40
2.2	The Relationship of Holomorphic and Harmonic Functions . .	45
2.2.1	Harmonic Functions	45
2.2.2	Holomorphic and Harmonic Functions	46
2.3	Real and Complex Line Integrals	50
2.3.1	Curves	51
2.3.2	Closed Curves	51
2.3.3	Differentiable and C^k Curves	52
2.3.4	Integrals on Curves	53
2.3.5	The Fundamental Theorem of Calculus along Curves .	54
2.3.6	The Complex Line Integral	54
2.3.7	Properties of Integrals	56
2.4	Complex Differentiability and Conformality	61
2.4.1	Conformality	61
2.5	The Logarithm	66
3	The Cauchy Theory	71
3.1	The Cauchy Integral Theorem and Formula	71
3.1.1	The Cauchy Integral Theorem, Basic Form	71
3.1.2	More General Forms of the Cauchy Theorem	73
3.1.3	Deformability of Curves	75
3.1.4	Cauchy Integral Formula, Basic Form	79
3.1.5	More General Versions of the Cauchy Formula	82
3.2	Variants of the Cauchy Formula	87
3.3	A Coda on the Limitations of the Cauchy Formula	88
4	Applications of the Cauchy Theory	93
4.1	The Derivatives of a Holomorphic Function	93
4.1.1	A Formula for the Derivative	94
4.1.2	The Cauchy Estimates	94
4.1.3	Entire Functions and Liouville's Theorem	96
4.1.4	The Fundamental Theorem of Algebra	97
4.1.5	Sequences of Holomorphic Functions and Their Derivatives	98
4.1.6	The Power Series Representation of a Holomorphic Function	99

4.1.7	Table of Elementary Power Series	104
4.2	The Zeros of a Holomorphic Function	107
4.2.1	The Zero Set of a Holomorphic Function	107
4.2.2	Discrete Sets and Zero Sets	108
4.2.3	Uniqueness of Analytic Continuation	110
5	Isolated Singularities and Laurent Series	115
5.1	The Behavior of a Holomorphic Function near an Isolated Singularity	115
5.1.1	Isolated Singularities	115
5.1.2	A Holomorphic Function on a Punctured Domain	115
5.1.3	Classification of Singularities	116
5.1.4	Removable Singularities, Poles, and Essential Singularities	116
5.1.5	The Riemann Removable Singularities Theorem	117
5.1.6	The Casorati-Weierstrass Theorem	117
5.1.7	Concluding Remarks	118
5.2	Expansion around Singular Points	120
5.2.1	Laurent Series	120
5.2.2	Convergence of a Doubly Infinite Series	121
5.2.3	Annulus of Convergence	121
5.2.4	Uniqueness of the Laurent Expansion	122
5.2.5	The Cauchy Integral Formula for an Annulus	122
5.2.6	Existence of Laurent Expansions	123
5.2.7	Holomorphic Functions with Isolated Singularities	126
5.2.8	Classification of Singularities in Terms of Laurent Series	126
5.3	Examples of Laurent Expansions	129
5.3.1	Principal Part of a Function	129
5.3.2	Algorithm for Calculating the Coefficients of the Laurent Expansion	131
5.4	The Calculus of Residues	135
5.4.1	Functions with Multiple Singularities	135
5.4.2	The Concept of Residue	135
5.4.3	The Residue Theorem	136
5.4.4	Residues	137
5.4.5	The Index or Winding Number of a Curve about a Point	139

5.4.6	Restatement of the Residue Theorem	140
5.4.7	Method for Calculating Residues	141
5.4.8	Summary Charts of Laurent Series and Residues	141
5.5	Applications to the Calculation of Definite Integrals and Sums	146
5.5.1	The Evaluation of Definite Integrals	146
5.5.2	A Basic Example	146
5.5.3	Complexification of the Integrand	149
5.5.4	An Example with a More Subtle Choice of Contour	150
5.5.5	Making the Spurious Part of the Integral Disappear	153
5.5.6	The Use of the Logarithm	155
5.5.7	Summary Chart of Some Integration Techniques	157
5.6	Meromorphic Functions and Singularities at Infinity	161
5.6.1	Meromorphic Functions	161
5.6.2	Discrete Sets and Isolated Points	161
5.6.3	Definition of a Meromorphic Function	161
5.6.4	Examples of Meromorphic Functions	162
5.6.5	Meromorphic Functions with Infinitely Many Poles	162
5.6.6	Singularities at Infinity	162
5.6.7	The Laurent Expansion at Infinity	163
5.6.8	Meromorphic at Infinity	163
5.6.9	Meromorphic Functions in the Extended Plane	164
6	The Argument Principle	167
6.1	Counting Zeros and Poles	167
6.1.1	Local Geometric Behavior of a Holomorphic Function	167
6.1.2	Locating the Zeros of a Holomorphic Function	167
6.1.3	Zero of Order n	168
6.1.4	Counting the Zeros of a Holomorphic Function	170
6.1.5	The Idea of the Argument Principle	171
6.1.6	Location of Poles	173
6.1.7	The Argument Principle for Meromorphic Functions	173
6.2	The Local Geometry of Holomorphic Functions	176
6.2.1	The Open Mapping Theorem	176
6.3	Further Results on the Zeros of Holomorphic Functions	180
6.3.1	Rouché's Theorem	180
6.3.2	Typical Application of Rouché's Theorem	181
6.3.3	Rouché's Theorem and the Fundamental Theorem of Algebra	182

6.3.4	Hurwitz's Theorem	182
6.4	The Maximum Principle	184
6.4.1	The Maximum Modulus Principle	184
6.4.2	Boundary Maximum Modulus Theorem	185
6.4.3	The Minimum Modulus Principle	185
6.5	The Schwarz Lemma	187
6.5.1	Schwarz's Lemma	188
6.5.2	The Schwarz-Pick Lemma	189
7	The Geometric Theory of Holomorphic Functions	193
7.1	The Idea of a Conformal Mapping	193
7.1.1	Conformal Mappings	193
7.1.2	Conformal Self-Maps of the Plane	194
7.2	Conformal Mappings of the Unit Disc	196
7.2.1	Conformal Self-Maps of the Disc	196
7.2.2	Möbius Transformations	197
7.2.3	Self-Maps of the Disc	197
7.3	Linear Fractional Transformations	199
7.3.1	Linear Fractional Mappings	199
7.3.2	The Topology of the Extended Plane	200
7.3.3	The Riemann Sphere	201
7.3.4	Conformal Self-Maps of the Riemann Sphere	202
7.3.5	The Cayley Transform	203
7.3.6	Generalized Circles and Lines	203
7.3.7	The Cayley Transform Revisited	203
7.3.8	Summary Chart of Linear Fractional Transformations	204
7.4	The Riemann Mapping Theorem	206
7.4.1	The Concept of Homeomorphism	206
7.4.2	The Riemann Mapping Theorem	206
7.4.3	The Riemann Mapping Theorem: Second Formulation	206
7.5	Conformal Mappings of Annuli	208
7.5.1	A Mapping Theorem for Annuli	208
7.5.2	Conformal Equivalence of Annuli	208
7.5.3	Classification of Planar Domains	209
7.6	A Compendium of Useful Conformal Mappings	211

8	Applications That Depend on Conformal Mapping	225
8.1	Conformal Mapping	225
8.1.1	The Utility of Conformal Mappings	225
8.2	Application of Conformal Mapping to the Dirichlet Problem	226
8.2.1	The Dirichlet Problem	226
8.2.2	Physical Motivation for the Dirichlet Problem	226
8.3	Physical Examples Solved by Means of Conformal Mapping	231
8.3.1	Steady State Heat Distribution on a Lens-Shaped Region	232
8.3.2	Electrostatics on a Disc	234
8.3.3	Incompressible Fluid Flow around a Post	235
8.4	Numerical Techniques of Conformal Mapping	239
8.4.1	Numerical Approximation of the Schwarz-Christoffel Mapping	240
8.4.2	Numerical Approximation to a Mapping onto a Smooth Domain	245
9	Harmonic Functions	249
9.1	Basic Properties of Harmonic Functions	249
9.1.1	The Laplace Equation	249
9.1.2	Definition of Harmonic Function	250
9.1.3	Real- and Complex-Valued Harmonic Functions	250
9.1.4	Harmonic Functions as the Real Parts of Holomorphic Functions	250
9.1.5	Smoothness of Harmonic Functions	251
9.2	The Mean Value Property and the Maximum Principle	253
9.2.1	The Mean Value Property	253
9.2.2	The Maximum Principle for Harmonic Functions	254
9.2.3	The Minimum Principle for Harmonic Functions	254
9.2.4	Why the Mean Value Property Implies the Maximum Principle	254
9.2.5	The Boundary Maximum and Minimum Principle	255
9.2.6	Boundary Uniqueness for Harmonic Functions	256
9.3	The Poisson Integral Formula	257
9.3.1	The Poisson Integral	257
9.3.2	The Poisson Kernel	257
9.3.3	The Dirichlet Problem	258
9.3.4	The Solution of the Dirichlet Problem on the Disc	258

9.3.5	The Dirichlet Problem on a General Disc	260
10	Transform Theory	263
10.0	Introductory Remarks	263
10.1	Fourier Series	263
10.1.1	Basic Definitions	263
10.1.2	A Remark on Intervals of Arbitrary Length	265
10.1.3	Calculating Fourier Coefficients	266
10.1.4	Calculating Fourier Coefficients Using Complex Analysis	267
10.1.5	Steady State Heat Distribution	268
10.1.6	The Derivative and Fourier Series	270
10.2	The Fourier Transform	274
10.2.1	Basic Definitions	274
10.2.2	Some Fourier Transform Examples That Use Complex Variables	275
10.2.3	Solving a Differential Equation Using the Fourier Transform	284
10.3	The Laplace Transform	287
10.3.1	Prologue	287
10.3.2	Solving a Differential Equation Using the Laplace Transform	288
10.4	A Table of Laplace Transforms	289
10.5	The z -Transform	291
10.5.1	Basic Definitions	291
10.5.2	Population Growth by Means of the z -Transform	292
11	Partial Differential Equations (PDEs) and Boundary Value Problems	295
11.1	Fourier Methods in the Theory of Differential Equations	295
11.1.1	Remarks on Different Fourier Notations	295
11.1.2	The Dirichlet Problem on the Disc	297
11.1.3	The Poisson Integral	302
11.1.4	The Wave Equation	304
12	Computer Packages for Studying Complex Variables	319
12.0	Introductory Remarks	319
12.1	The Software Packages	320

12.1.1	The Software $f(z)^{\text{®}}$	320
12.1.2	Mathematica $^{\text{®}}$	321
12.1.3	Maple $^{\text{®}}$	328
12.1.4	MatLab $^{\text{®}}$	330
12.1.5	Ricci $^{\text{®}}$	330
APPENDICES		333
Solutions to Odd-Numbered Exercises		335
Glossary of Terms from Complex Variable Theory and Analysis		357
List of Notation		399
A Guide to the Literature		403
Bibliography		409
Index		413

Preface

Complex variables is one of the grand old ladies of mathematics. Originally conceived in the pursuit of solutions of polynomial equations, complex variables blossomed in the hands of Euler, Argand, and others into the free-standing subject of complex analysis.

Like the negative numbers and zero, complex numbers were at first viewed with some suspicion. To be sure, they were useful tools for solving certain types of problems. But what were they precisely and where did they come from? What did they correspond to in the real world?

Today we have a much more concrete, and more catholic, view of the matter. First, we now know how to construct the complex numbers using rigorous mathematical techniques. Second, we understand how complex eigenvalues arise in the study of mechanical vibrations, how complex functions model incompressible fluid flow, and how complex variables enable the Fourier transform and the solution of a variety of differential equations that arise from physics and engineering.

It is essential for the modern undergraduate engineering student, as well as the math major and the physics major, to understand the basics of complex variable theory. The need then is for a textbook that presents the elements of the subject while requiring only a solid background in the calculus of one and several variables. This is such a text. There are, of course, other solid books for such a course. The book of Brown and Churchill has stood for many editions. The book of Saff and Snider, a more recent offering, is well-written and incisive. The book of Derrick features stimulating applications. What makes this text distinctive are the following features:

- (1) We work in ideas from physics and engineering beginning in Chapter 1, and continuing throughout the book. Applications are an integral part of the presentation at every stage.

- (2) Every chapter contains exercises that illustrate the applications.
- (3) There are both exercises and text examples that illustrate the use of computer algebra systems in complex analysis.
- (4) A very important attribute (and one not well represented in any other book) is that this text presents the subject of complex analysis as a natural continuation of the calculus. Most complex analysis texts exhibit the subject as a freestanding collection of ideas, independent of other parts of mathematical analysis and having its own body of techniques and tricks. This is in fact a misrepresentation of the discipline and leads to copious misunderstanding and misuse of the ideas. We are able to present complex analysis as part and parcel of the world view that the student has developed in his or her earlier course work. The result is that students can master the material more effectively and use it with good result in other courses in engineering and physics.
- (5) The book has stimulating exercises at the three levels of drill, exploration, and theory. There is a comfortable balance between theory and applications.
- (6) Most sections have examples that illustrate both the theory and the practice of complex variables.
- (7) The book has many illustrations which clarify key concepts from complex variable theory.
- (8) We use differential equations to illustrate important concepts throughout the book.
- (9) We integrate **MatLab** exercises and examples throughout.

The subject of complex variables has many aspects—from the algebraic features of a complete number field, to the analytic properties imposed by the Cauchy integral formula, to the geometric qualities coming from the idea of conformality. The student must be acquainted with all components of the field. This text speaks all the languages, and shows the student how to deal with all the different approaches to complex analysis. The examples illustrate all the key concepts, while the exercises reinforce the basic skills, and provide practice in all the fundamental ideas.

As noted, we shall integrate **MatLab** activities throughout. Computer algebra systems have become an important and central tool in modern mathematical science, and **MatLab** has proved to be of particular utility in the engineering world. **MatLab** is particularly well adapted to use in complex variable theory. Here we show the student, in a natural context, how **MatLab** calculations can play a role in complex variables.

There is too much material in this book for a one-semester course. Some thought must be given as to how to design a course from this book. Any course should cover Chapters 1 through 5. Finishing off with Sections 7.1 through 7.3 and Chapter 8 will give a very basic grounding in the subject. Chapters 10 and 11 are great for applications and instructors can dip into them as time permits.

A more thoroughgoing course would want to cover the remainder of Chapter 7 and at least some of Chapter 6. As noted, Chapters 10 and 11 give the student a detailed glimpse of how complex variables are used in the real world. Chapter 9, on harmonic functions, is more advanced material and should perhaps be saved for a two-term course. Chapter 12 is dessert, for those who want to explore computer tools that can be used in the study of complex variables.

Complex variables is a vibrant area of mathematical research, and it interacts fruitfully with many other parts of mathematics. It is an essential tool in applications. This text will illustrate and teach all facets of the subject in a lively manner that will speak to the needs of modern students. It will give them a powerful toolkit for future work in the mathematical sciences, and will also point to new directions for additional learning.

MATLAB[®] is a trademark of The MathWorks, Inc. and is used with permission. The Mathworks does not warrant the accuracy of the text or exercises in this book. This book's use or discussion of MATLAB[®] software or related products does not constitute endorsement or sponsorship by The Math Works of a particular pedagogical approach or particular use of the MATLAB[®] software.

I conclude by thanking my editor Bob Stern for encouraging me to write this book and providing all needed assistance. He engaged some exceptionally careful and proactive reviewers who provided valuable advice and encouragement. Working with Taylor & Francis is always a pleasure.

Chapter 1

Basic Ideas

1.1 Complex Arithmetic

1.1.1 The Real Numbers

The real number system consists of both the rational numbers (numbers with terminating or repeating decimal expansions) and the irrational numbers (numbers with infinite, nonrepeating decimal expansions). The real numbers are denoted by the symbol \mathbb{R} . We let $\mathbb{R}^2 = \{(x, y) : x \in \mathbb{R}, y \in \mathbb{R}\}$ (Figure 1.1).

1.1.2 The Complex Numbers

The complex numbers \mathbb{C} consist of \mathbb{R}^2 equipped with some special algebraic operations. One defines

$$\begin{aligned}(x, y) + (x', y') &= (x + x', y + y'), \\ (x, y) \cdot (x', y') &= (xx' - yy', xy' + yx').\end{aligned}$$

These operations of $+$ and \cdot are commutative and associative.

EXAMPLE 1 We may calculate that

$$(3, 7) + (2, -4) = (3 + 2, 7 + (-4)) = (5, 3).$$

Also

$$(3, 7) \cdot (2, -4) = (3 \cdot 2 - 7 \cdot (-4), 3 \cdot (-4) + 7 \cdot 2) = (34, 2).$$

□

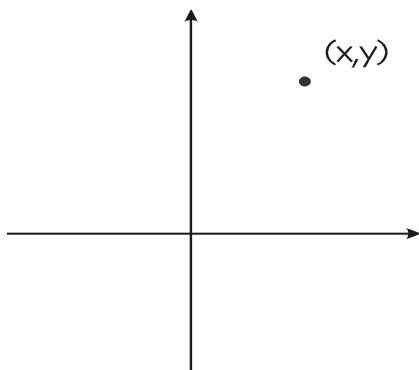


Figure 1.1: A point in the plane.

Of course we sometimes wish to subtract complex numbers. We define

$$z - w = z + (-w).$$

Thus if $z = (11, -6)$ and $w = (1, 4)$ then

$$z - w = z + (-w) = (11, -6) + (-1, -4) = (10, -10).$$

We denote $(1, 0)$ by 1 and $(0, 1)$ by i . We also denote $(0, 0)$ by 0 . If $\alpha \in \mathbb{R}$, then we identify α with the complex number $(\alpha, 0)$. Using this notation, we see that

$$\alpha \cdot (x, y) = (\alpha, 0) \cdot (x, y) = (\alpha x, \alpha y). \quad (1.1)$$

In particular,

$$1 \cdot (x, y) = (1, 0) \cdot (x, y) = (x, y).$$

We may calculate that

$$x \cdot 1 + y \cdot i = (x, 0) \cdot (1, 0) + (y, 0) \cdot (0, 1) = (x, 0) + (0, y) = (x, y).$$

Thus every complex number (x, y) can be written in one and only one fashion in the form $x \cdot 1 + y \cdot i$ with $x, y \in \mathbb{R}$. We usually write the number even more succinctly as $x + iy$.

EXAMPLE 2 The complex number $(-2, 5)$ is usually written as

$$(-2, 5) = -2 + 5i.$$

The complex number $(4, 9)$ is usually written as

$$(4, 9) = 4 + 9i.$$

The complex number $(-3, 0)$ is usually written as

$$(-3, 0) = -3 + 0i = -3.$$

The complex number $(0, 6)$ is usually written as

$$(0, 6) = 0 + 6i = 6i.$$

□

In this more commonly used notation, laws of addition and multiplication become

$$\begin{aligned}(x + iy) + (x' + iy') &= (x + x') + i(y + y'), \\ (x + iy) \cdot (x' + iy') &= (xx' - yy') + i(xy' + yx').\end{aligned}$$

Observe that $i \cdot i = -1$. Indeed,

$$i \cdot i = (0, 1) \cdot (0, 1) = (0 \cdot 0 - 1 \cdot 1) + i(0 \cdot 1 + 1 \cdot 0) = -1 + 0i = -1.$$

This is historically the single most important fact about the complex numbers—that they provide negative numbers with square roots. More generally, the complex numbers provide *any polynomial equation* with roots. We shall develop these ideas in detail below.

Certainly our multiplication law is consistent with the scalar multiplication introduced in line (1.1).

Insight: The multiplicative law presented at the beginning of Section 1.1.2 may at first seem strange and counter-intuitive. Why not take the simplest possible route and define

$$(x, y) \cdot (x', y') = (xx', yy')? \tag{1.2}$$

This would certainly be easier to remember, and is consistent with what one might guess. The trouble is that definition (1.2), while simple, has a number of liabilities. First of all, it would lead to

$$(1, 0) \cdot (0, 1) = (0, 0) = 0.$$

Thus we would have the product of two nonzero numbers equaling zero—an eventuality that we want to always avoid in any arithmetic. Second, the main point of the complex numbers is that we want a negative number to have a square root. That would not happen if (1.2) were our definition of multiplication.

The definition at the start of Section 1.1.2 is in fact a very clever idea that creates a *new number system* with many marvelous new properties. The purpose of this text is to acquaint you with this new world. \square

EXAMPLE 3 The fact that $i \cdot i = -1$ means that the number -1 has a square root. This fact is at first counterintuitive. If we stick to the real number system, then only nonnegative numbers have square roots. In the complex number system, *any* number has a square root—in fact any nonzero number has two of them.¹ For example,

$$(1 + i)^2 = 2i$$

and

$$(-1 - i)^2 = 2i.$$

Later in this chapter we will learn how to find both the square roots, and in fact all the n th roots, of any complex number. \square

EXAMPLE 4 The syntax in `MatLab` for complex number arithmetic is simple and straightforward. Refer to the basic manual [PRA] for key ideas. A complex number in `MatLab` may be written as `a + bi` or `a + b*i`.

In order to calculate $(3 - 2i) \cdot (1 + 4i)$ using `MatLab`, one enters the code

```
>>(3 - 2i)*(1 + 4i)
```

Here `>>` is the standard `MatLab` prompt. `MatLab` instantly gives the answer `11 + 10i`. \square

¹The number 0 has just one square root. It is the only root of the polynomial equation $z^2 = 0$. All other complex numbers α have two distinct square roots. They are the roots of the polynomial equation $z^2 = \alpha$ or $z^2 - \alpha = 0$. The matter will be treated in greater detail below. In particular, we shall be able to put these ideas in the context of the Fundamental Theorem of Algebra.

The symbols z, w, ζ are frequently used to denote complex numbers. We usually take $z = x + iy$, $w = u + iv$, $\zeta = \xi + i\eta$. The real number x is called the *real part* of z and is written $x = \operatorname{Re} z$. The real number y is called the *imaginary part* of z and is written $y = \operatorname{Im} z$.

EXAMPLE 5 The real part of the complex number $z = 4 - 8i$ is 4. We write

$$\operatorname{Re} z = 4.$$

The imaginary part of z is -8 . We write

$$\operatorname{Im} z = -8.$$

□

EXAMPLE 6 Addition of complex numbers corresponds exactly to addition of vectors in the plane. Specifically, if $z = x + iy$ and $w = u + iv$ then

$$z + w = (x + u) + i(y + v).$$

If we make the correspondence

$$z = x + iy \leftrightarrow \mathbf{z} = \langle x, y \rangle$$

and

$$w = u + iv \leftrightarrow \mathbf{w} = \langle u, v \rangle$$

then we have

$$\mathbf{z} + \mathbf{w} = \langle x, y \rangle + \langle u, v \rangle = \langle x + u, y + v \rangle.$$

Clearly

$$(x + u) + i(y + v) \leftrightarrow \langle x + u, y + v \rangle.$$

But complex multiplication *does not* correspond to any standard vector operation. Indeed it cannot. For the standard vector dot product has no concept of multiplicative inverse; and the standard vector cross product has no concept of multiplicative inverse. But one of the main points of the complex number operations is that they turn this number system into a *field*: every nonzero number does indeed have a multiplicative inverse. This is a very special property of two-dimensional space. There is no other Euclidean space (except of course the real line) that can be equipped with commutative operations of addition and multiplication so that **(i)** every number has an additive inverse and **(ii)** every nonzero number has a multiplicative inverse. We shall learn more about these ideas below. □

The complex number $x - iy$ is by definition the complex *conjugate* of the complex number $x + iy$. If $z = x + iy$, then we denote the conjugate² of z with the symbol \bar{z} ; thus $\bar{z} = x - iy$.

1.1.3 Complex Conjugate

Note that $z + \bar{z} = 2x$, $z - \bar{z} = 2iy$. Also

$$\begin{aligned}\overline{z + w} &= \bar{z} + \bar{w}, \\ \overline{z \cdot w} &= \bar{z} \cdot \bar{w}.\end{aligned}$$

A complex number is real (has no imaginary part) if and only if $z = \bar{z}$. It is imaginary (has no real part) if and only if $z = -\bar{z}$.

EXAMPLE 7 Let $z = -7 + 6i$ and $w = 4 - 9i$. Then

$$\bar{z} = -7 - 6i$$

and

$$\bar{w} = 4 + 9i.$$

Notice that

$$\bar{z} + \bar{w} = (-7 - 6i) + (4 + 9i) = -3 + 3i,$$

and that number is exactly the conjugate of

$$z + w = -3 - 3i.$$

Notice also that

$$\bar{z} \cdot \bar{w} = (-7 - 6i) \cdot (4 + 9i) = 26 - 87i,$$

and that number is exactly the conjugate of

$$z \cdot w = 26 + 87i.$$

□

²Rewriting history a bit, we may account for the concept of “conjugate” as follows. If $p(z) = az^2 + bz + c$ is a polynomial with real coefficients, and if $z = x + iy$ is a root of this polynomial, then $\bar{z} = x - iy$ will also be a root of that same polynomial. This assertion is immediate from the quadratic formula, or by direct calculation. Thus $x + iy$ and $x - iy$ are *conjugate roots* of the polynomial p .

EXAMPLE 8 Conjugation of a complex number is a straightforward operation. But `MatLab` can do it for you. The `MatLab` code

```
>>conj(8 - 7i)
```

yields the output

```
8 + 7i.
```

□

Exercises

1. Let $z = 13 + 5i$, $w = 2 - 6i$, and $\zeta = 1 + 9i$. Calculate $z + w$, $w - \zeta$, $z \cdot \zeta$, $w \cdot \zeta$, and $\zeta - z$.
2. Let $z = 4 - 7i$, $w = 1 + 3i$, and $\zeta = 2 + 2i$. Calculate \bar{z} , $\bar{\zeta}$, $\overline{z - w}$, $\overline{\zeta + z}$, $\overline{\zeta \cdot w}$.
3. If $z = 6 - 2i$, $w = 4 + 3i$, and $\zeta = -5 + i$, then calculate $z + \bar{z}$, $z + 2\bar{z}$, $z - \bar{w}$, $z \cdot \bar{\zeta}$, and $w \cdot \bar{\zeta}^2$.
4. If z is a complex number then \bar{z} has the same distance from the origin as z . Explain why.
5. If z is a complex number then \bar{z} and z are situated symmetrically with respect to the x -axis. Explain why.
6. If z is a complex number then $-\bar{z}$ and z are situated symmetrically with respect to the y -axis. Explain why.
7. Explain why addition in the real numbers is a special case of addition in the complex numbers. Explain why the two operations are logically consistent.
8. Explain why multiplication in the real numbers is a special case of multiplication in the complex numbers. Explain why the two operations are logically consistent.
9. Use `MatLab` to calculate the conjugates of $9 + 4i$, $6 - 3i$, and $2 + i$.

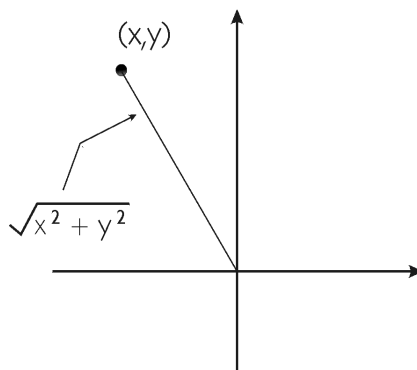


Figure 1.2: Distance to the origin or modulus.

10. Let $z = 10 + 2i$, $w = 4 - 6i$. Use `MatLab` to calculate $z \cdot w$, $\bar{z} \cdot w$, $z + w$, and $z - \bar{w}$.
11. Let $z = a + ib$ and $w = c + id$ be complex numbers. These correspond, in an obvious way, to points (a, b) and (c, d) in the plane, and these in turn correspond to vectors $Z = \langle a, b \rangle$ and $W = \langle c, d \rangle$.

Verify that addition of z and w as complex numbers corresponds in a natural way to addition of the vectors Z and W . What does multiplication of the complex numbers z and w correspond to vis a vis the vectors?

1.2 Algebraic and Geometric Properties

1.2.1 Modulus of a Complex Number

The ordinary Euclidean distance of (x, y) to $(0, 0)$ is $\sqrt{x^2 + y^2}$ (Figure 1.2). We also call this number the *modulus* of the complex number $z = x + iy$ and we write $|z| = \sqrt{x^2 + y^2}$. Note that

$$z \cdot \bar{z} = x^2 + y^2 = |z|^2. \quad (1.3)$$

The distance from z to w is $|z - w|$. We also have the easily verified formulas $|zw| = |z||w|$ and $|\operatorname{Re} z| \leq |z|$ and $|\operatorname{Im} z| \leq |z|$.

The very important *triangle inequality* says that

$$|z + w| \leq |z| + |w|.$$

We shall discuss this relation in greater detail below. For now, the interested reader may wish to square both sides, cancel terms, and see what the inequality reduces to.

EXAMPLE 9 The complex number $z = 7 - 4i$ has modulus given by

$$|z| = \sqrt{7^2 + (-4)^2} = \sqrt{65}.$$

The complex number $w = 2 + i$ has modulus given by

$$|w| = \sqrt{2^2 + 1^2} = \sqrt{5}.$$

Finally, the complex number $z + w = 9 - 3i$ has modulus given by

$$|z + w| = \sqrt{9^2 + (-3)^2} = \sqrt{90}.$$

According to the triangle inequality,

$$|z + w| \leq |z| + |w|,$$

and we may now confirm this arithmetically as

$$\sqrt{90} \leq \sqrt{65} + \sqrt{5}.$$

□

EXAMPLE 10 MatLab can perform modulus calculations quickly and easily. The MatLab code

```
>>abs(6 - 8i)
```

yields the output

```
10.
```

The input

```
>>abs(2 + 7i)
```

yields the output

```
7.2801.
```

□

1.2.2 The Topology of the Complex Plane

If P is a complex number and $r > 0$, then we set

$$D(P, r) = \{z \in \mathbb{C} : |z - P| < r\}$$

and

$$\overline{D}(P, r) = \{z \in \mathbb{C} : |z - P| \leq r\}.$$

The first of these is the *open disc with center P and radius r* ; the second is the *closed disc with center P and radius r* (Figure 1.3). Notice that the closed disc includes its boundary (indicated in the figure with a solid line for the boundary) while the open disc does not (indicated in the figure with a dashed line for the boundary). We often use the simpler symbols D and \overline{D} to denote, respectively, the discs $D(0, 1)$ and $\overline{D}(0, 1)$.

We say that a set $U \subseteq \mathbb{C}$ is *open* if, for each $P \in U$, there is an $r > 0$ such that $D(P, r) \subseteq U$. Thus an open set is one with the property that each point P of the set is surrounded by neighboring points (that is, the points of distance less than r from P) that are still in the set—see Figure 1.4. Of course the number r will depend on P . As examples, $U = \{z \in \mathbb{C} : \operatorname{Re} z > 1\}$ is open, but $F = \{z \in \mathbb{C} : \operatorname{Re} z \leq 1\}$ is not (Figure 1.5). Observe that, in these figures, we use a *solid line* to indicate that the boundary is included in the set; we use a *dotted line* to indicate that the boundary is not included in the set.

A set $E \subseteq \mathbb{C}$ is said to be *closed* if $\mathbb{C} \setminus E \equiv \{z \in \mathbb{C} : z \notin E\}$ (the complement of E in \mathbb{C}) is open. [Note that when the universal set is understood—in this case \mathbb{C} —we sometimes use the notation ${}^c E$ to denote the complement.] The set F in the last paragraph is closed.

It is *not* the case that any given set is either open or closed. For example, the set $W = \{z \in \mathbb{C} : 1 < \operatorname{Re} z \leq 2\}$ is *neither open nor closed* (Figure 1.6).

We say that a set $E \subset \mathbb{C}$ is *connected* if there do not exist nonempty disjoint open sets U and V such that $U \cap E \neq \emptyset$, $V \cap E \neq \emptyset$, and $E = (U \cap E) \cup (V \cap E)$. Refer to Figure 1.7 for these ideas. We say that U and V *separate* E . It is a useful fact that if E is an open set, then E is connected if and only if it is path-connected; this means that any two points of E can be connected by a continuous path or curve that lies entirely in the set. See Figure 1.8.

In practice we recognize a connected set as follows. If $E \subseteq \mathbb{C}$ is a set and there is a proper subset $S \subseteq E$ (proper means that S is not all of E) such

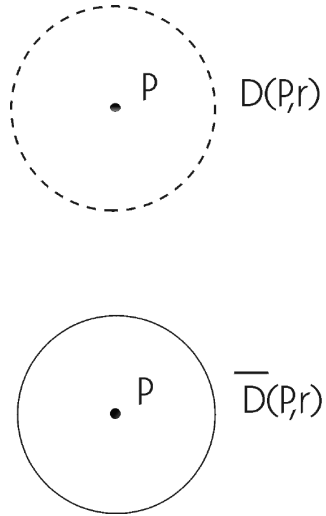


Figure 1.3: An open disc and a closed disc.

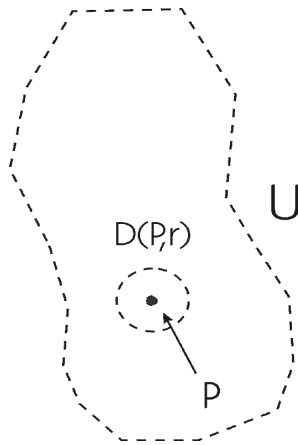


Figure 1.4: An open set.

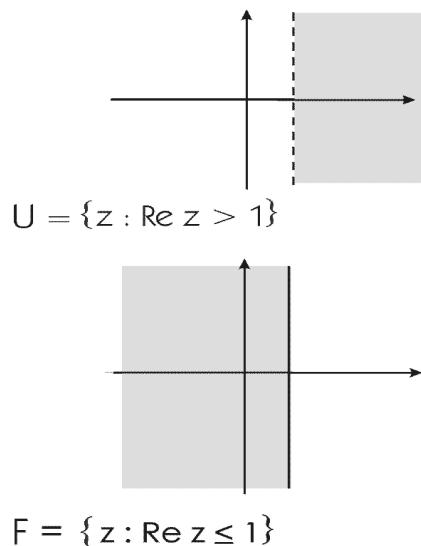


Figure 1.5: An open set and a nonopen set.

that S is both open and closed, then $U = S$ and $V = {}^c S$ are both open and separate E so that E is disconnected. Thus connectedness of E means that *there is no proper subset of E that is both open and closed.*

Much of our analysis in this book will be on domains in the plane. A *domain* is a connected open set. We also use the word *region* alternatively with “domain.”

1.2.3 The Complex Numbers as a Field

Let 0 denote the complex number $0 + i0$. If $z \in \mathbb{C}$, then $z + 0 = z$. Also, letting $-z = -x - iy$, we have $z + (-z) = 0$. So every complex number has an additive inverse, and that inverse is unique. One may also readily verify that $0 \cdot z = z \cdot 0 = 0$ for any complex number z .

Since $1 = 1 + i0$, it follows that $1 \cdot z = z \cdot 1 = z$ for every complex number z . If $z \neq 0$, then $|z|^2 \neq 0$ and

$$z \cdot \left(\frac{\bar{z}}{|z|^2} \right) = \frac{|z|^2}{|z|^2} = 1. \quad (1.4)$$

So every nonzero complex number has a multiplicative inverse, and that

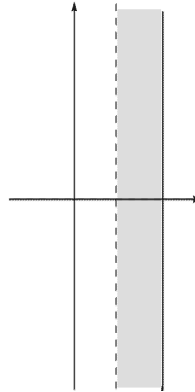


Figure 1.6: A set that is neither open nor closed.

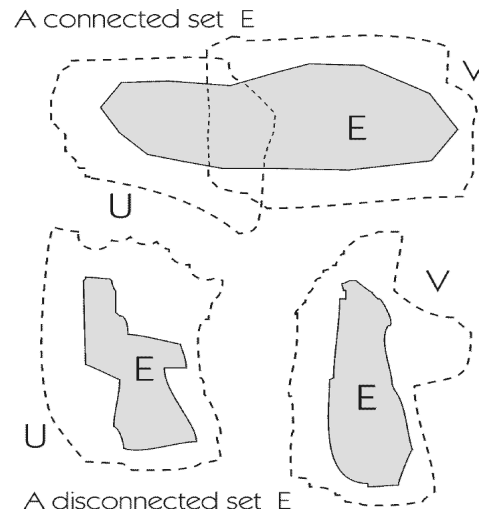


Figure 1.7: A connected set and a disconnected set.

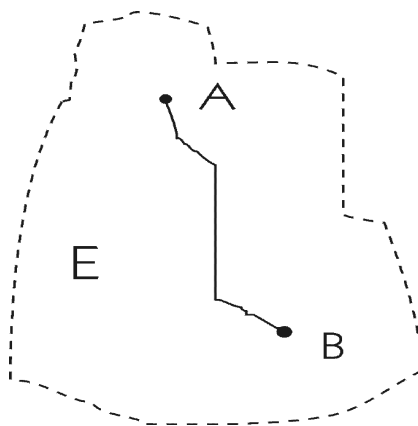


Figure 1.8: An open set is connected if and only if it is path-connected.

inverse is unique. It is natural to define $1/z$ to be the multiplicative inverse $\bar{z}/|z|^2$ of z and, more generally, to define

$$\frac{z}{w} = z \cdot \frac{1}{w} = \frac{z\bar{w}}{|w|^2} \quad \text{for } w \neq 0. \quad (1.5)$$

We also have $\overline{z/w} = \bar{z}/\bar{w}$.

It must be stressed that $1/z$ makes good sense as an intuitive object but *not as a complex number*. A complex number is, by definition, one that is written in the form $x + iy$ —which $1/z$ most definitely is not. But we have declared

$$\frac{1}{z} = \frac{\bar{z}}{|z|^2} = \frac{x - iy}{|z|^2} = \frac{x}{|z|^2} - i \cdot \frac{y}{|z|^2},$$

and this is definitely in the form of a complex number.

EXAMPLE 11 The idea of multiplicative inverse in the complex numbers is at first counterintuitive. So let us look at a specific instance.

Let $z = 2 + 3i$. It is all too easy to say that the multiplicative inverse of z is

$$\frac{1}{z} = \frac{1}{2 + 3i}.$$

The trouble is that, as written, $1/(2 + 3i)$ is *not* a complex number. Recall that a complex number is a number of the form $x + iy$. But our discussion preceding this example enables us to clarify the matter.

Because in fact the multiplicative inverse of $2 + 3i$ is

$$\frac{\bar{z}}{|z|^2} = \frac{2 - 3i}{13}.$$

The advantage of looking at things this way is that the multiplicative inverse is in fact now a complex number; it is

$$\frac{2}{13} - i\frac{3}{13}.$$

And we may check directly that this number does the job:

$$(2+3i) \cdot \left(\frac{2}{13} - i\frac{3}{13} \right) = \left(2 \cdot \frac{2}{13} + 3 \cdot \frac{3}{13} \right) + i \left(2 \cdot \left(-\frac{3}{13} \right) + 3 \cdot \frac{2}{13} \right) = 1 + 0i = 1.$$

□

Multiplication and addition satisfy the usual distributive, associative, and commutative laws. Therefore \mathbb{C} is a *field* (see [HER]). The field \mathbb{C} contains a copy of the real numbers in an obvious way:

$$\mathbb{R} \ni x \mapsto x + i0 \in \mathbb{C}. \quad (1.6)$$

This identification respects addition and multiplication. So we can think of \mathbb{C} as a field extension of \mathbb{R} : it is a larger field which contains the field \mathbb{R} .

1.2.4 The Fundamental Theorem of Algebra

It is not true that every nonconstant polynomial with real coefficients has a real root. For instance, $p(x) = x^2 + 1$ has no real roots. The Fundamental Theorem of Algebra states that every polynomial with complex coefficients has a complex root (see the treatment in Sections 4.1.4, 6.3.3). The complex field \mathbb{C} is the *smallest* field that contains \mathbb{R} and has this so-called algebraic closure property.

Exercises

1. Let $z = 6 - 9i$, $w = 4 + 2i$, $\zeta = 1 + 10i$. Calculate $|z|$, $|w|$, $|z + w|$, $|\zeta - w|$, $|z \cdot w|$, $|z + w|$, $|\zeta \cdot z|$. Confirm directly that

$$|z + w| \leq |z| + |w|,$$

$$|z \cdot w| = |z||w|,$$

$$|\zeta \cdot z| = |\zeta||z|.$$

2. Find complex numbers z, w such that $|z| = 5$, $|w| = 7$, $|z + w| = 9$.
3. Find complex numbers z, w such that $|z| = 1$, $|w| = 1$, and $z/w = i^3$.
4. Let $z = 4 - 6i$, $w = 2 + 7i$. Calculate z/w , w/z , and $1/w$.
5. Sketch these discs on the same set of axes: $D(2 + 3i, 4)$, $D(1 - 2i, 2)$, $\overline{D}(i, 5)$, $\overline{D}(6 - 2i, 5)$.
6. Which of these sets is open? Which is closed? Why or why not?
 - (a) $\{x + iy \in \mathbb{C} : x^2 + 4y^2 \leq 4\}$
 - (b) $\{x + iy \in \mathbb{C} : x < y\}$
 - (c) $\{x + iy \in \mathbb{C} : 2 \leq x + y < 5\}$
 - (d) $\{x + iy \in \mathbb{C} : 4 < \sqrt{x^2 + 3y^2}\}$
 - (e) $\{x + iy \in \mathbb{C} : 5 \leq \sqrt{x^4 + 2y^6}\}$
7. Consider the polynomial $p(z) = z^3 - z^2 + 2z - 2$. How many real roots does p have? How many complex roots? Explain.
8. The polynomial $q(z) = z^3 - 3z + 2$ is of degree three, yet it does *not* have three distinct roots. Explain.
9. Use `MatLab` to calculate $|3 + 6i|$, $|4 - 2i|$, and $|8 + 7i|$.
10. Let $z = 2 - 6i$ and $w = 9 + 3i$. Use `MatLab` to calculate z/w , w/\overline{z}^2 , and $z \cdot (w + \overline{z})/\overline{w}$.
11. Use `MatLab` to test whether any of $-i$, i , or $1 + i$ is a root of the polynomial $p(z) = z^3 - 3z + 4i$.
12. Use `MatLab` to find all the complex roots of the polynomial $p(z) = z^4 - 3z^3 + 2z - 1$. Call the roots $\alpha_1, \alpha_2, \alpha_3, \alpha_4$. Calculate explicitly the product

$$Q(z) = (z - \alpha_1) \cdot (z - \alpha_2) \cdot (z - \alpha_3) \cdot (z - \alpha_4).$$

Observe that $Q(z) = p(z)$. Is this a coincidence?

13. Use `MatLab` if convenient to produce a fourth-degree polynomial that has roots $2 - 3i$, $4 + 7i$, $8 - 2i$, and $6 + 6i$. This polynomial is unique up to a constant multiple. Explain why.
14. Write a fourth degree polynomial $q(z)$ whose roots are 1 , -1 , i , and $-i$. These four numbers are all the fourth roots of 1 . Explain therefore why q has such a simple form.
15. If z is a nonzero complex number, then it has a reciprocal $1/z$ that is also a complex number. Now if Z is the planar vector corresponding to z , then what vector does $1/z$ correspond to? [**Hint:** Think in terms of reflection in a circle.]

1.3 The Exponential and Applications

1.3.1 The Exponential Function

We define the complex exponential as follows:

(1.7) If $z = x$ is real, then

$$e^z = e^x \equiv \sum_{n=0}^{\infty} \frac{x^n}{n!}$$

as in calculus. Here $!$ denotes the usual “factorial” operation:

$$n! = n \cdot (n - 1) \cdot (n - 2) \cdots 3 \cdot 2 \cdot 1.$$

(1.8) If $z = iy$ is pure imaginary, then

$$e^z = e^{iy} \equiv \cos y + i \sin y.$$

[This identity, due to Euler, is discussed below.]

(1.9) If $z = x + iy$, then

$$e^z = e^{x+iy} \equiv e^x \cdot e^{iy} = e^x \cdot (\cos y + i \sin y).$$

This tri-part definition may seem a bit mysterious. But we may justify it formally as follows (a detailed discussion of complex power series will come later). Consider the definition

$$e^z = \sum_{n=0}^{\infty} \frac{z^n}{n!}. \quad (1.10)$$

This is a natural generalization of the familiar definition of the exponential function from calculus.

We may write this out as

$$e^z = 1 + z + \frac{z^2}{2!} + \frac{z^3}{3!} + \frac{z^4}{4!} + \cdots. \quad (1.11)$$

In case $z = x$ is real, this gives the familiar

$$e^x = 1 + x + \frac{x^2}{2!} + \frac{x^3}{3!} + \frac{x^4}{4!} + \cdots.$$

In case $z = iy$ is pure imaginary, then (1.11) gives

$$e^{iy} = 1 + iy - \frac{y^2}{2!} - i\frac{y^3}{3!} + \frac{y^4}{4!} + i\frac{y^5}{5!} - \frac{y^6}{6!} - i\frac{y^7}{7!} + \cdots. \quad (1.12)$$

Grouping the real terms and the imaginary terms we find that

$$e^{iy} = \left[1 - \frac{y^2}{2!} + \frac{y^4}{4!} - \frac{y^6}{6!} + \cdots \right] + i \left[y - \frac{y^3}{3!} + \frac{y^5}{5!} - \frac{y^7}{7!} + \cdots \right] = \cos y + i \sin y. \quad (1.13)$$

This is the same as the definition that we gave above in (1.8).

Part (1.9) of the definition is of course justified by the usual rules of exponentiation.

An immediate consequence of this new definition of the complex exponential is the following complex-analytic definition of the sine and cosine functions:

$$\cos z = \frac{e^{iz} + e^{-iz}}{2}, \quad (1.14)$$

$$\sin z = \frac{e^{iz} - e^{-iz}}{2i}. \quad (1.15)$$

Note that when $z = x + i0$ is real this new definition is consistent³ with the familiar Euler formula from calculus:

$$e^{ix} = \cos x + i \sin x. \quad (1.16)$$

³The key fact here is that, since $e^{ix} = \cos x + i \sin x$ then $e^{-ix} = \cos x - i \sin x$. Thus also $e^{iz} = \cos z + i \sin z$ and $e^{-iz} = \cos z - i \sin z$.

It is sometimes useful to rewrite equation (1.14) as

$$\begin{aligned}
 \cos z &= \frac{e^{iz} + e^{-iz}}{2} \\
 &= \frac{e^{ix-y} + e^{-ix+y}}{2} \\
 &= \frac{(\cos x + i \sin x)e^{-y} + (\cos x - i \sin x)e^y}{2} \\
 &= \cos x \cdot \frac{e^y + e^{-y}}{2} - i \sin x \cdot \frac{e^y - e^{-y}}{2} \\
 &= \cos x \cosh y - i \sin x \sinh y.
 \end{aligned}$$

Similarly, one can show that

$$\sin z = \sin x \cosh y + i \cos x \sinh y.$$

1.3.2 Laws of Exponentiation

The complex exponential satisfies familiar rules of exponentiation:⁴

$$e^{z+w} = e^z \cdot e^w \quad \text{and} \quad (e^z)^w = e^{zw} \quad \text{for } w \text{ an integer.} \quad (1.17)$$

Note that we may rewrite the second of these formulas as

$$(e^z)^n = \underbrace{e^z \cdots e^z}_{n \text{ times}} = e^{nz}. \quad (1.18)$$

1.3.3 The Polar Form of a Complex Number

A consequence of our first definition of the complex exponential—see (1.8)—is that if $\zeta \in \mathbb{C}$, $|\zeta| = 1$, then there is a unique number θ , $0 \leq \theta < 2\pi$, such that $\zeta = e^{i\theta}$ (see Figure 1.9). Here θ is the (signed) angle between the positive x axis and the ray $\overrightarrow{0\zeta}$.

Now if z is any nonzero complex number, then

$$z = |z| \cdot \left(\frac{z}{|z|} \right) \equiv |z| \cdot \zeta \quad (1.19)$$

⁴The formula $(e^z)^w$ requires further elucidation. The expression *does* make sense for w not an integer, but the complex logarithm function must be used in the process. See the development below.

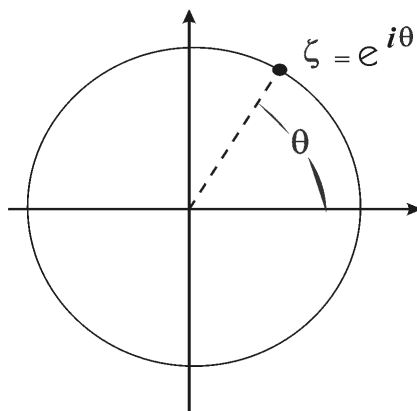


Figure 1.9: Polar coordinates of a point in the plane.

where $\zeta \equiv z/|z|$ has modulus 1. Again, letting θ be the angle between the positive real axis and $\vec{0\zeta}$, we see that

$$\begin{aligned} z &= |z| \cdot \zeta \\ &= |z|e^{i\theta} \\ &= re^{i\theta}, \end{aligned} \tag{1.20}$$

where $r = |z|$. This form is called the *polar* representation for the complex number z . (Note that some classical books write the expression $z = re^{i\theta} = r(\cos \theta + i \sin \theta)$ as $z = r \operatorname{cis} \theta$. The reader should be aware of this notation, though we shall not use it in the present book.)

EXAMPLE 12 Let $z = 1 + \sqrt{3}i$. Then $|z| = \sqrt{1^2 + (\sqrt{3})^2} = 2$. Hence

$$z = 2 \cdot \left(\frac{1}{2} + i \frac{\sqrt{3}}{2} \right). \tag{1.21}$$

The number in parentheses is of unit modulus and subtends an angle of $\pi/3$ with the positive x -axis. Therefore

$$1 + \sqrt{3}i = z = 2 \cdot e^{i\pi/3}. \tag{1.22}$$

□

It is often convenient to allow angles that are greater than or equal to 2π in the polar representation; when we do so, the polar representation is no longer unique. For if k is an integer, then

$$\begin{aligned} e^{i\theta} &= \cos \theta + i \sin \theta \\ &= \cos(\theta + 2k\pi) + i \sin(\theta + 2k\pi) \\ &= e^{i(\theta + 2k\pi)}. \end{aligned} \tag{1.23}$$

Remark: Of course the inverse of the exponential function is the (complex) logarithm. This is a rather subtle idea, and will be investigated in Section 2.5.

Exercises

1. Calculate (with your answer in the form $a + ib$) the values of $e^{\pi i}$, $e^{(\pi/3)i}$, $5e^{-i(\pi/4)}$, $2e^i$, $7e^{-3i}$.
2. Write these complex numbers in polar form: $2 + 2i$, $1 + \sqrt{3}i$, $\sqrt{3} - i$, $\sqrt{2} - i\sqrt{2}$, i , $-1 - i$.
3. If $e^z = 2 - 2i$ then what can you say about z ? [**Hint:** There is more than one answer.]
4. If $w^5 = z$ and $|z| = 3$ then what can you say about $|w|$?
5. If $w^5 = z$ and z subtends an angle of $\pi/4$ with the positive x -axis, then what can you say about the angle that w subtends with the positive x -axis? [**Hint:** There is more than one answer to this question.]
6. Calculate that $|e^z| = e^x$. Also $|\cos z|^2 = \cos^2 x \cosh^2 y + \sin^2 x \sinh^2 y$ and $|\sin z|^2 = \sin^2 x \cosh^2 y + \cos^2 x \sinh^2 y$.
7. If $w^2 = z^3$ then how are the polar forms of z and w related?
8. Write all the polar forms of the complex number $-\sqrt{2} + i\sqrt{6}$.
9. If $z = re^{i\theta}$ and $w = se^{i\psi}$ then what can you say about the polar form of $z + w$? What about $z \cdot w$?

10. Use `MatLab` to calculate $e^{i\pi/3}$, e^{1-i} , and $e^{-3\pi i/4}$. [**Hint:** The `MatLab` symbol for π is `pi`. The symbol for exponentiation is `^`. Be sure to use `*` for multiplication when appropriate.]
11. Use `MatLab` functions to calculate the polar form of the complex numbers $2-5i$, $3+7i$, $6+4i$. [**Hint:** The trigonometric functions in `MatLab` are given by `sin()`, `cos()`, `tan()` and the inverse trigonometric functions by `asin()`, `acos()`, and `atan()`.]
12. Use `MatLab` to convert these complex numbers in polar form to standard rectilinear form: $4e^{5i}$, $-6e^{-3i}$, $2e^{\pi^2 i}$.
13. Use `MatLab` to calculate the rectangular form of the complex numbers $\sqrt{3}e^{i\pi/3}$, $\sqrt{8}e^{-2\pi/3}$, $\sqrt{5}e^{i\pi/6}$, and $\sqrt{2}e^{-\pi/3}$.
14. Let $w = 3e^{i\pi/3}$. Calculate w^2 , w^3 , $1/w$ and $w + 1$. Use `MatLab` if you wish.
15. Explain why there is no complex number z such that $e^z = 0$.
16. Suppose that z and w are complex numbers that are related by the formula $z = e^w$. Each of z and w corresponds to a vector in the plane. How are these vectors related?

1.3.4 Roots of Complex Numbers

The properties of the exponential operation can be used, together with the polar representation, to find the n^{th} roots of a complex number.

EXAMPLE 13 To find all sixth roots of 2, we let $re^{i\theta}$ be an arbitrary sixth root of 2 and solve for r and θ . If

$$(re^{i\theta})^6 = 2 = 2 \cdot e^{i0} \quad (1.24)$$

or

$$r^6 e^{i6\theta} = 2 \cdot e^{i0}, \quad (1.25)$$

then it follows that $r = 2^{1/6} \in \mathbb{R}$ and $\theta = 0$ solve this equation. So the real number $2^{1/6} \cdot e^{i0} = 2^{1/6}$ is a sixth root of two. This is not terribly surprising, but we are not finished.

We may also solve

$$r^6 e^{i6\theta} = 2 = 2 \cdot e^{2\pi i}. \quad (1.26)$$

Notice that we are taking advantage of the ambiguity built into the polar representation: The number 2 may be written as $2 \cdot e^{i0}$, but it may also be written as $2 \cdot e^{2\pi i}$ or as $2 \cdot e^{4\pi i}$, and so forth.

Hence

$$r = 2^{1/6}, \quad \theta = 2\pi/6 = \pi/3. \quad (1.27)$$

This gives us the number

$$2^{1/6} e^{i\pi/3} = 2^{1/6} (\cos \pi/3 + i \sin \pi/3) = 2^{1/6} \left(\frac{1}{2} + i \frac{\sqrt{3}}{2} \right) \quad (1.28)$$

as a sixth root of two. Similarly, we can solve

$$\begin{aligned} r^6 e^{i6\theta} &= 2 \cdot e^{4\pi i} \\ r^6 e^{i6\theta} &= 2 \cdot e^{6\pi i} \\ r^6 e^{i6\theta} &= 2 \cdot e^{8\pi i} \\ r^6 e^{i6\theta} &= 2 \cdot e^{10\pi i} \end{aligned}$$

to obtain the other four sixth roots of 2:

$$2^{1/6} \left(-\frac{1}{2} + i \frac{\sqrt{3}}{2} \right) \quad (1.29)$$

$$-2^{1/6} \quad (1.30)$$

$$2^{1/6} \left(-\frac{1}{2} - i \frac{\sqrt{3}}{2} \right) \quad (1.31)$$

$$2^{1/6} \left(\frac{1}{2} - i \frac{\sqrt{3}}{2} \right). \quad (1.32)$$

These are in fact all the sixth roots of 2. □

Remark: Notice that, in the last example, the process must stop after six roots. For if we solve

$$r^6 e^{i6\theta} = 2 \cdot e^{12\pi i},$$

then we find that $r = 2^{1/6}$ as usual and $\theta = 2\pi$. This yields the complex root

$$z = 2^{1/6} \cdot e^{2\pi i} = 1^{1/6},$$

and that simply repeats the first root that we found. If we were to continue with $14\pi i$, $16\pi i$, and so forth, we would just repeat the other roots.

EXAMPLE 14 Let us find all third roots of i . We begin by writing i as

$$i = e^{i\pi/2}. \quad (1.33)$$

Solving the equation

$$(re^{i\theta})^3 = i = e^{i\pi/2} \quad (1.34)$$

then yields $r = 1$ and $\theta = \pi/6$.

Next, we write $i = e^{i5\pi/2}$ and solve

$$(re^{i\theta})^3 = e^{i5\pi/2} \quad (1.35)$$

to obtain that $r = 1$ and $\theta = 5\pi/6$.

Finally we write $i = e^{i9\pi/2}$ and solve

$$(re^{i\theta})^3 = e^{i9\pi/2} \quad (1.36)$$

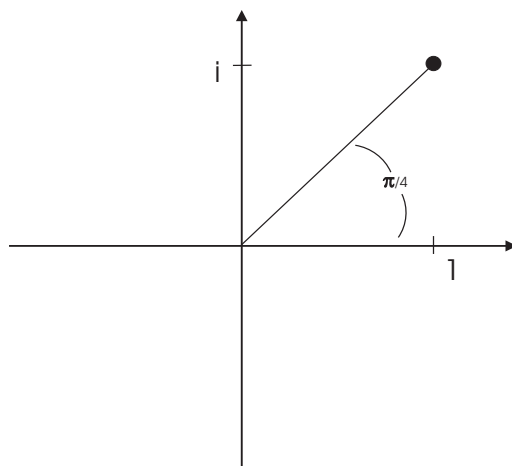
to obtain that $r = 1$ and $\theta = 9\pi/6 = 3\pi/2$.

In summary, the three cube roots of i are

$$\begin{aligned} e^{i\pi/6} &= \frac{\sqrt{3}}{2} + i\frac{1}{2}, \\ e^{i5\pi/6} &= -\frac{\sqrt{3}}{2} + i\frac{1}{2}, \\ e^{i3\pi/2} &= -i. \end{aligned}$$

□

It is worth taking the time to sketch the six sixth roots of 2 (from Example 13) on a single set of axes. Also sketch all the third roots of i on a single set of axes. Observe that the six sixth roots of 2 are equally spaced about a circle that is centered at the origin and has radius $2^{1/6}$. Likewise, the three cube roots of i are equally spaced about a circle that is centered at the origin and has radius 1.

Figure 1.10: The argument of $1 + i$.

1.3.5 The Argument of a Complex Number

The (nonunique) angle θ associated to a complex number $z \neq 0$ is called its *argument*, and is written $\arg z$. For instance, $\arg(1 + i) = \pi/4$. See Figure 1.10. But it is also correct to write $\arg(1 + i) = 9\pi/4, 17\pi/4, -7\pi/4$, etc. We generally choose the argument θ to satisfy $0 \leq \theta < 2\pi$. This is the *principal branch* of the argument—see Sections 2.5, 5.5 where the idea is applied to good effect.

Under multiplication of complex numbers (in polar form), arguments are additive and moduli multiply. That is, if $z = re^{i\theta}$ and $w = se^{i\psi}$, then

$$z \cdot w = re^{i\theta} \cdot se^{i\psi} = (rs) \cdot e^{i(\theta+\psi)}. \quad (1.37)$$

1.3.6 Fundamental Inequalities

We next record a few inequalities.

The Triangle Inequality: If $z, w \in \mathbb{C}$, then

$$|z + w| \leq |z| + |w|. \quad (1.38)$$

More generally,

$$\left| \sum_{j=1}^n z_j \right| \leq \sum_{j=1}^n |z_j|. \quad (1.39)$$

For the verification of (1.38), square both sides. We obtain

$$|z + w|^2 \leq (|z| + |w|)^2$$

or

$$(z + w) \cdot \overline{(z + w)} \leq (|z| + |w|)^2.$$

Multiplying this out yields

$$|z|^2 + z\bar{w} + w\bar{z} + |w|^2 \leq |z|^2 + 2|z||w| + |w|^2.$$

Cancelling like terms yields

$$2\operatorname{Re}(z\bar{w}) \leq 2|z||w|$$

or

$$\operatorname{Re}(z\bar{w}) \leq |z||w|.$$

It is convenient to rewrite this as

$$\operatorname{Re}(z\bar{w}) \leq |z\bar{w}|. \quad (1.40)$$

But it is true, for any complex number ζ , that $|\operatorname{Re} \zeta| \leq |\zeta|$. Our argument runs both forward and backward. So (1.40) implies (1.38). This establishes the basic triangle inequality.

To give an idea of why the more general triangle inequality is true, consider just three terms. We have

$$\begin{aligned} |z_1 + z_2 + z_3| &= |z_1 + (z_2 + z_3)| \\ &\leq |z_1| + |z_2 + z_3| \\ &\leq |z_1| + (|z_2| + |z_3|), \end{aligned}$$

thus establishing the general result for three terms. The full inequality for n terms is proved similarly.

The Cauchy-Schwarz Inequality: If z_1, \dots, z_n and w_1, \dots, w_n are complex numbers, then

$$\left| \sum_{j=1}^n z_j w_j \right|^2 \leq \left[\sum_{j=1}^n |z_j|^2 \right] \cdot \left[\sum_{j=1}^n |w_j|^2 \right]. \quad (1.41)$$

To understand why this inequality is true, let us begin with some special cases. For just one summand, the inequality says that

$$|z_1 w_1|^2 \leq |z_1|^2 |w_1|^2,$$

which is clearly true. For two summands, the inequality asserts that

$$|z_1 w_1 + z_2 w_2|^2 \leq (|z_1|^2 + |z_2|^2) \cdot (|w_1|^2 + |w_2|^2).$$

Multiplying this out yields

$$|z_1 w_1|^2 + 2\operatorname{Re}(z_1 w_1 \overline{z_2 w_2}) + |z_2 w_2|^2 \leq |z_1|^2 |w_1|^2 + |z_1|^2 |w_2|^2 + |z_2|^2 |w_1|^2 + |z_2|^2 |w_2|^2.$$

Cancelling like terms, we have

$$2\operatorname{Re}(z_1 w_1 \overline{z_2 w_2}) \leq |z_1|^2 |w_2|^2 + |z_2|^2 |w_1|^2.$$

But it is always true, for $a, b \geq 0$, that $2ab \leq a^2 + b^2$. Hence

$$2\operatorname{Re}(z_1 w_1 \overline{z_2 w_2}) \leq 2|z_1 w_2| |z_2 w_1| \leq |z_1 w_2|^2 + |z_2 w_1|^2.$$

The result for n terms is proved similarly.

Exercises

1. Find all the third roots of $3i$.
2. Find all the sixth roots of -1 .
3. Find all the fourth roots of $-5i$.
4. Find all the fifth roots of $-1 + i$.
5. Find all third roots of $3 - 6i$.

6. Find all arguments of each of these complex numbers: i , $1+i$, $-1+i\sqrt{3}$, $-2-2i$, $\sqrt{3}-i$.

7. If z is any complex number then explain why

$$|z| \leq |\operatorname{Re} z| + |\operatorname{Im} z|.$$

8. If z is any complex number then explain why

$$|\operatorname{Re} z| \leq |z| \quad \text{and} \quad |\operatorname{Im} z| \leq |z|.$$

9. If z, w are any complex numbers then explain why

$$|z+w| \geq |z| - |w|.$$

10. If $\sum_n |z_n|^2 < \infty$ and $\sum_n |w_n|^2 < \infty$ then explain why $\sum_n |z_n w_n| < \infty$.

11. Use **MatLab** to find all cube roots of i . Now calculate those roots by hand. [**Hint:** Use a fractional power, together with \wedge , to determine the roots of any number.] Use **MatLab** to take suitable third powers to check your work.

12. Use **MatLab** to find all the square roots and all the fourth roots of $1+i$. Now perform the same calculation by hand. Use **MatLab** to take suitable second and fourth powers to check your work.

13. Use **MatLab** to calculate

$$\sqrt{1-4i+\sqrt[3]{3-i}}.$$

It would be quite complicated to calculate this number in the form $a+ib$ by hand, but you may wish to try. [**Hint:** There is a complication lurking in the background here. Any complex number except 0 has multiple roots. This is because of a built-in ambiguity in the definition of the logarithm—see Section 2.5. You need not worry about this subtlety now, but it may affect the answer(s) that **MatLab** gives you.]

14. Use **MatLab** to calculate the square root of

$$z = e^{i\pi/3} + 2e^{-i\pi/4}.$$

15. Find the polar form of the complex number $z = -1$. Find all fourth roots of -1 .
16. The Cauchy-Schwarz inequality has an interpretation in terms of vectors. What is it? What does the inequality say about the cosine of an angle?

Chapter 2

The Relationship of Holomorphic and Harmonic Functions

2.1 Holomorphic Functions

2.1.1 Continuously Differentiable and C^k Functions

Holomorphic functions are a generalization of complex polynomials. But they are more flexible objects than polynomials. The collection of all polynomials is closed under addition and multiplication. However, the collection of all holomorphic functions is closed under reciprocals, division, inverses, exponentiation, logarithms, square roots, and many other operations as well.

There are several different ways to introduce the concept of holomorphic function. They can be defined by way of power series, or using the complex derivative, or using partial differential equations. We shall touch on all these approaches; but our initial definition will be by way of partial differential equations.

If $U \subseteq \mathbb{R}^2$ is a region and $f : U \rightarrow \mathbb{R}$ is a continuous function, then f is called C^1 (or *continuously differentiable*) on U if $\partial f/\partial x$ and $\partial f/\partial y$ exist and are *continuous* on U . We write $f \in C^1(U)$ for short.

More generally, if $k \in \{0, 1, 2, \dots\}$, then a real-valued function f on U is called C^k (k times continuously differentiable) if all partial derivatives of f up to and including order k exist and are continuous on U . We write in this case $f \in C^k(U)$. In particular, a C^0 function is just a continuous function.

We say that a function is C^∞ if it is C^k for every k . Such a function is called *infinitely differentiable*.

EXAMPLE 15 Let $D \subseteq \mathbb{C}$ be the unit disc, $D = \{z \in \mathbb{C} : |z| < 1\}$. The function $\varphi(z) = |z|^2 = x^2 + y^2$ is C^k for every k . This is so just because we may differentiate φ as many times as we please, and the result is continuous. In this circumstance we sometimes write $\varphi \in C^\infty$.

By contrast, the function $\psi(z) = |z|$ is not even C^1 . For the restriction of ψ to the real axis is $\tilde{\psi}(x) = |x|$, and this function is well known not to be differentiable at $x = 0$. \square

A function $f = u + iv : U \rightarrow \mathbb{C}$ is called C^k if both u and v are C^k .

2.1.2 The Cauchy-Riemann Equations

If f is *any* complex-valued function, then we may write $f = u + iv$, where u and v are real-valued functions.

EXAMPLE 16 Consider

$$f(z) = z^2 = (x^2 - y^2) + i(2xy); \quad (2.1)$$

in this example $u = x^2 - y^2$ and $v = 2xy$. We refer to u as the *real part* of f and denote it by $\operatorname{Re} f$; we refer to v as the *imaginary part* of f and denote it by $\operatorname{Im} f$. \square

Now we formulate the notion of “holomorphic function” in terms of the real and imaginary parts of f :

Let $U \subseteq \mathbb{C}$ be a region and $f : U \rightarrow \mathbb{C}$ a C^1 function. Write

$$f(z) = u(x, y) + iv(x, y), \quad (2.2)$$

with u and v real-valued functions. Of course $z = x + iy$ as usual. If u and v satisfy the equations

$$\frac{\partial u}{\partial x} = \frac{\partial v}{\partial y} \quad \frac{\partial u}{\partial y} = -\frac{\partial v}{\partial x} \quad (2.3)$$

at every point of U , then the function f is said to be *holomorphic* (see Section 2.1.4, where a more formal definition of “holomorphic” is provided). The first order, linear partial differential equations in (2.3) are called the *Cauchy-Riemann equations*. A practical method for checking whether a given function is holomorphic is to check whether it satisfies the Cauchy-Riemann equations. Another practical method is to check that the function can be expressed in terms of z alone, with no \bar{z} 's present (see Section 2.1.3).

EXAMPLE 17 Let $f(z) = z^2 - z$. Then we may write

$$f(z) = (x + iy)^2 - (x + iy) = (x^2 - y^2 - x) + i(2xy - y) \equiv u(x, y) + iv(x, y).$$

Then we may check directly that

$$\frac{\partial u}{\partial x} = 2x - 1 = \frac{\partial v}{\partial y}$$

and

$$\frac{\partial v}{\partial x} = 2y = -\frac{\partial u}{\partial y}.$$

We see, then, that f satisfies the Cauchy-Riemann equations so it is holomorphic. Also observe that f may be expressed in terms of z alone, with no \bar{z} 's. \square

EXAMPLE 18 Define

$$g(z) = |z|^2 - 4z + 2\bar{z} = z \cdot \bar{z} - 4z + 2\bar{z} = (x^2 + y^2 - 2x) + i(-6y) \equiv u(x, y) + iv(x, y).$$

Then

$$\frac{\partial u}{\partial x} = 2x - 2 \neq -6 = \frac{\partial v}{\partial y}.$$

Also

$$\frac{\partial v}{\partial x} = 0 \neq -2y = -\frac{\partial u}{\partial y}.$$

We see that *both* Cauchy-Riemann equations fail. So g is not holomorphic. We may also observe that g is expressed both in terms of z and \bar{z} —another sure indicator that this function is not holomorphic. \square

2.1.3 Derivatives

We define, for $f = u + iv : U \rightarrow \mathbb{C}$ a C^1 function,

$$\frac{\partial}{\partial z} f \equiv \frac{1}{2} \left(\frac{\partial}{\partial x} - i \frac{\partial}{\partial y} \right) f = \frac{1}{2} \left(\frac{\partial u}{\partial x} + \frac{\partial v}{\partial y} \right) + \frac{i}{2} \left(\frac{\partial v}{\partial x} - \frac{\partial u}{\partial y} \right) \quad (2.4)$$

and

$$\frac{\partial}{\partial \bar{z}} f \equiv \frac{1}{2} \left(\frac{\partial}{\partial x} + i \frac{\partial}{\partial y} \right) f = \frac{1}{2} \left(\frac{\partial u}{\partial x} - \frac{\partial v}{\partial y} \right) + \frac{i}{2} \left(\frac{\partial v}{\partial x} + \frac{\partial u}{\partial y} \right). \quad (2.5)$$

If $z = x + iy$, $\bar{z} = x - iy$, then one can check directly that

$$\frac{\partial}{\partial z} z = 1, \quad \frac{\partial}{\partial z} \bar{z} = 0, \quad (2.6)$$

$$\frac{\partial}{\partial \bar{z}} z = 0, \quad \frac{\partial}{\partial \bar{z}} \bar{z} = 1. \quad (2.7)$$

In traditional multivariable calculus, the partial derivatives $\partial/\partial x$ and $\partial/\partial y$ span all directions in the plane: *any* directional derivative can be expressed in terms of $\partial/\partial x$ and $\partial/\partial y$. Put in other words, if f is a continuously differentiable function in the plane, if $\partial f/\partial x \equiv 0$ and $\partial f/\partial y \equiv 0$, then *all* directional derivatives of f are identically 0. Hence f is constant. So it is with $\partial/\partial z$ and $\partial/\partial \bar{z}$. If $\partial f/\partial z \equiv 0$ and $\partial f/\partial \bar{z} \equiv 0$ then *all* directional derivatives of f are identically 0. Hence f is constant.

The partial derivatives $\partial/\partial z$ and $\partial/\partial \bar{z}$ are most convenient for complex analysis because they interact naturally with the complex coordinate functions z and \bar{z} (as noted above). And, because of the Cauchy-Riemann equations, they characterize holomorphic functions. Just as a function that satisfies $\partial f/\partial x \equiv 0$ is a function that is independent of x , so it is the case that a function that satisfies $\partial f/\partial \bar{z} \equiv 0$ is independent of \bar{z} ; it only depends on z . Thus it is holomorphic.

Of course

$$x = \frac{z + \bar{z}}{2} \quad \text{and} \quad y = \frac{z - \bar{z}}{2i}.$$

We may use this information, together with

$$\frac{\partial}{\partial z} = \frac{\partial x}{\partial z} \cdot \frac{\partial}{\partial x} + \frac{\partial y}{\partial z} \cdot \frac{\partial}{\partial y},$$

to derive the formula for $\partial/\partial z$ and likewise for $\partial/\partial \bar{z}$.

If a C^1 function f satisfies $\partial f/\partial z \equiv 0$ on an open set U , then f does not depend on z (but it *can* depend on \bar{z}). If instead f satisfies $\partial f/\partial \bar{z} \equiv 0$ on an open set U , then f does not depend on \bar{z} (but it *does* depend on z). The condition $\partial f/\partial \bar{z} \equiv 0$ is just a reformulation of the Cauchy-Riemann equations—see Section 2.1.2. Thus $\partial f/\partial \bar{z} \equiv 0$ if and only if f is holomorphic. We work out the details of this claim in Section 2.1.4. Now we look at some examples to illustrate the new ideas.

EXAMPLE 19 Review Example 17. Now let us examine that same function using our new criterion with the operator $\partial/\partial \bar{z}$. We have

$$\frac{\partial}{\partial \bar{z}} f(z) = \frac{\partial}{\partial \bar{z}} (z^2 - z) = 2z \frac{\partial z}{\partial \bar{z}} - \frac{\partial z}{\partial \bar{z}} = 0 - 0 = 0.$$

We conclude that f is holomorphic. \square

EXAMPLE 20 Review Example 18. Now let us examine that same function using our new criterion with the operator $\partial/\partial \bar{z}$. We have

$$\frac{\partial}{\partial \bar{z}} g(z) = \frac{\partial}{\partial \bar{z}} (|z|^2 - 4z + 2\bar{z}) = \frac{\partial}{\partial \bar{z}} (z \cdot \bar{z} - 4z + 2\bar{z}) = z + 2 \neq 0.$$

We conclude that g is *not* holomorphic. \square

It is sometimes useful to express the derivatives $\partial/\partial z$ and $\partial/\partial \bar{z}$ in polar coordinates. Recall that

$$r^2 = x^2 + y^2, \quad x = r \cos \theta, \quad y = r \sin \theta.$$

Now notices that

$$\frac{\partial}{\partial x} = \frac{\partial r}{\partial x} \cdot \frac{\partial}{\partial r} + \frac{\partial \theta}{\partial x} \cdot \frac{\partial}{\partial \theta} = \frac{x}{r} \cdot \frac{\partial}{\partial r} - \frac{y}{r^2} \cdot \frac{\partial}{\partial \theta} = \cos \theta \frac{\partial}{\partial r} - \frac{\sin \theta}{r} \cdot \frac{\partial}{\partial \theta}.$$

A similar calculation shows that

$$\frac{\partial}{\partial y} = \sin \theta \cdot \frac{\partial}{\partial r} + \frac{\cos \theta}{r} \cdot \frac{\partial}{\partial \theta}.$$

As a result, we see that

$$\frac{\partial}{\partial z} = \frac{1}{2} \left(\cos \theta \cdot \frac{\partial}{\partial r} - \frac{\sin \theta}{r} \cdot \frac{\partial}{\partial \theta} \right) - \frac{i}{2} \left(\sin \theta \cdot \frac{\partial}{\partial r} + \frac{\cos \theta}{r} \cdot \frac{\partial}{\partial \theta} \right)$$

and

$$\frac{\partial}{\partial \bar{z}} = \frac{1}{2} \left(\cos \theta \cdot \frac{\partial}{\partial r} - \frac{\sin \theta}{r} \cdot \frac{\partial}{\partial \theta} \right) + \frac{i}{2} \left(\sin \theta \cdot \frac{\partial}{\partial r} + \frac{\cos \theta}{r} \cdot \frac{\partial}{\partial \theta} \right).$$

We invite the reader to write $z = re^{i\theta} = r \cos \theta + ir \sin \theta$ and check directly (in polar coordinates) that $\partial z/\partial z \equiv 1$. Likewise verify that $\partial \bar{z}/\partial \bar{z} \equiv 1$.

2.1.4 Definition of a Holomorphic Function

Functions f that satisfy $(\partial/\partial\bar{z})f \equiv 0$ are the main concern of complex analysis. A continuously differentiable (C^1) function $f : U \rightarrow \mathbb{C}$ defined on an open subset U of \mathbb{C} is said to be *holomorphic* if

$$\frac{\partial f}{\partial \bar{z}} = 0 \quad (2.8)$$

at every point of U . Note that this last equation is just a reformulation of the Cauchy-Riemann equations (Section 2.1.2). To see this, we calculate:

$$\begin{aligned} 0 &= \frac{\partial}{\partial \bar{z}} f(z) \\ &= \frac{1}{2} \left(\frac{\partial}{\partial x} + i \frac{\partial}{\partial y} \right) [u(z) + iv(z)] \\ &= \left[\frac{\partial u}{\partial x} - \frac{\partial v}{\partial y} \right] + i \left[\frac{\partial u}{\partial y} + \frac{\partial v}{\partial x} \right]. \end{aligned} \quad (2.9)$$

Of course the far right-hand side cannot be identically zero unless each of its real and imaginary parts is identically zero. It follows that

$$\frac{\partial u}{\partial x} - \frac{\partial v}{\partial y} = 0 \quad (2.10)$$

and

$$\frac{\partial u}{\partial y} + \frac{\partial v}{\partial x} = 0. \quad (2.11)$$

These are the Cauchy-Riemann equations (2.3).

EXAMPLE 21 The function $h(z) = z^3 - 4z^2 + z$ is holomorphic because

$$\frac{\partial}{\partial \bar{z}} h(z) = 3z^2 \frac{\partial z}{\partial \bar{z}} - 4 \cdot 2z \frac{\partial z}{\partial \bar{z}} + \frac{\partial z}{\partial \bar{z}} = 0.$$

□

2.1.5 Examples of Holomorphic Functions

Certainly any polynomial in z (*without* \bar{z}) is holomorphic. And the reciprocal of any polynomial is holomorphic, as long as we restrict attention to a region where the polynomial does not vanish.

Earlier in this book we have discussed the complex function

$$e^z = \sum_{n=0}^{\infty} \frac{z^n}{n!}.$$

One may calculate directly, just differentiating the power series term-by-term, that

$$\frac{\partial}{\partial z} e^z = e^z.$$

In addition,

$$\frac{\partial}{\partial \bar{z}} e^z = 0,$$

so the exponential function is holomorphic.

Of course we know, and we have already noted, that

$$e^{x+iy} = e^x(\cos y + i \sin y).$$

When $x = 0$ this gives Euler's famous formula

$$e^{iy} = \cos y + i \sin y.$$

It follows immediately that

$$\cos y = \frac{e^{iy} + e^{-iy}}{2}$$

and

$$\sin y = \frac{e^{iy} - e^{-iy}}{2i}.$$

We explore other derivations of Euler's formula in the exercises.

In analogy with these basic formulas from calculus, we now define complex-analytic versions of the trigonometric functions:

$$\cos z = \frac{e^{iz} + e^{-iz}}{2}$$

and

$$\sin z = \frac{e^{iz} - e^{-iz}}{2i}.$$

The other trigonometric functions are defined in the usual way. For example,

$$\tan z = \frac{\sin z}{\cos z}.$$

We may calculate directly that

- (a) $\frac{\partial}{\partial z} \sin z = \cos z$;
- (b) $\frac{\partial}{\partial z} \cos z = -\sin z$;
- (c) $\frac{\partial}{\partial z} \tan z = \frac{1}{\cos^2 z} \equiv \sec^2 z$.

All of the trigonometric functions are holomorphic on their domains of definition. We invite the reader to verify this assertion.

It is straightforward to check that sums, products, and quotients of holomorphic functions are holomorphic (provided that we do not divide by 0). Any convergent power series—in powers of z only—defines a holomorphic function (just differentiate under the summation sign). We shall see later that holomorphic functions may be defined with integrals as well. So we now have a considerable panorama of holomorphic functions.

2.1.6 The Complex Derivative

Let $U \subseteq \mathbb{C}$ be open, $P \in U$, and $g : U \setminus \{P\} \rightarrow \mathbb{C}$ a function. We say that

$$\lim_{z \rightarrow P} g(z) = \ell, \quad \ell \in \mathbb{C}, \quad (2.12)$$

if, for any $\epsilon > 0$ there is a $\delta > 0$ such that when $z \in U$ and $0 < |z - P| < \delta$ then $|g(z) - \ell| < \epsilon$. Notice that, in this definition of limit, the point z may approach P in an arbitrary manner—from any direction. See Figure 2.1. Of course the function g is *continuous* at $P \in U$ if $\lim_{z \rightarrow P} g(z) = g(P)$.

We say that f possesses the *complex derivative* at P if

$$\lim_{z \rightarrow P} \frac{f(z) - f(P)}{z - P} \quad (2.13)$$

exists. In that case we denote the limit by $f'(P)$ or sometimes by

$$\frac{df}{dz}(P) \quad \text{or} \quad \frac{\partial f}{\partial z}(P). \quad (2.14)$$

This notation is consistent with that introduced in Section 2.1.3: for a *holomorphic function*, the complex derivative calculated according to formula (2.13) or according to formula (2.4) is just the same. We shall say more about the complex derivative in Section 2.2.1 and Section 2.2.2.

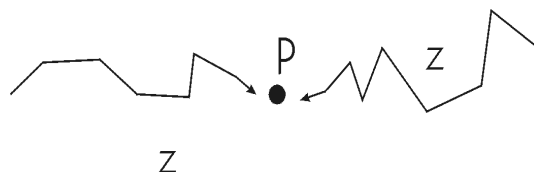


Figure 2.1: The point z may approach P arbitrarily.

We repeat that, in calculating the limit in (2.13), z must be allowed to approach P from *any* direction (refer to Figure 2.1). As an example, the function $g(x, y) = x - iy$ —equivalently, $g(z) = \bar{z}$ —does *not* possess the complex derivative at 0. To see this, calculate the limit

$$\lim_{z \rightarrow P} \frac{g(z) - g(P)}{z - P} \quad (2.15)$$

with z approaching $P = 0$ through values $z = x + i0$. The answer is

$$\lim_{x \rightarrow 0} \frac{x - 0}{x - 0} = 1. \quad (2.16)$$

If instead z is allowed to approach $P = 0$ through values $z = iy$, then the value is

$$\lim_{z \rightarrow P} \frac{g(z) - g(P)}{z - P} = \lim_{y \rightarrow 0} \frac{-iy - 0}{iy - 0} = -1. \quad (2.17)$$

Observe that the two answers do not agree. *In order for the complex derivative to exist, the limit must exist and assume only one value no matter how z approaches P .* Therefore this example g does not possess the complex derivative at $P = 0$. In fact a similar calculation shows that this function g does *not* possess the complex derivative at any point.

If a function f possesses the complex derivative at every point of its open domain U , then f is holomorphic. This definition is equivalent to definitions given in Section 2.1.4. We repeat some of these ideas in Section 2.2. In fact, from an historical perspective, it is important to recall a theorem of Goursat (see the Appendix in [GRK]). Goursat's theorem has great historical and philosophical significance, though it rarely comes up as a practical matter in complex function theory. We present it here in order to give the student some perspective. Goursat's result says that if a function f possesses the complex derivative at each point of an open region $U \subseteq \mathbb{C}$ then f is in fact

continuously differentiable¹ on U . One may then verify the Cauchy-Riemann equations, and it follows that f is holomorphic by any of our definitions thus far.

2.1.7 Alternative Terminology for Holomorphic Functions

Some books use the word “analytic” instead of “holomorphic.” Still others say “differentiable” or “complex differentiable” instead of “holomorphic.” The use of the term “analytic” derives from the fact that a holomorphic function has a local power series expansion about each point of its domain (see Section 4.1.6). In fact this power series property is a complete characterization of holomorphic functions; we shall discuss it in detail below. The use of “differentiable” derives from properties related to the complex derivative. These pieces of terminology and their significance will all be sorted out as the book develops. Somewhat archaic terminology for holomorphic functions, which may be found in older texts, are “regular” and “monogenic.”

Another piece of terminology that is applied to holomorphic functions is “conformal” or “conformal mapping.” “Conformality” is an important geometric property of holomorphic functions that make these functions useful for modeling incompressible fluid flow (Sections 8.2.2 and 8.3.3) and other physical phenomena. We shall discuss conformality in Section 2.4.1 and Chapter 7. We shall treat physical applications of conformality in Chapter 8.

Exercises

1. Verify that each of these functions is holomorphic wherever it is defined:

$$(a) \quad f(z) = \sin z - \frac{z^2}{z+1}$$

¹A more classical formulation of the result is this. If f possesses the complex derivative at each point of the region U , then f satisfies the Cauchy integral theorem (see Section 3.1.1 below). This is sometimes called the *Cauchy-Goursat theorem*. That in turn implies the Cauchy integral formula (Section 3.1.4). And this result allows us to prove that f is continuously differentiable (indeed infinitely differentiable).

(b) $g(z) = e^{2z-z^3} - z^2$

(c) $h(z) = \frac{\cos z}{z^2 + 1}$

(d) $k(z) = z(\tan z + z)$

2. Verify that each of these functions is *not* holomorphic:

(a) $f(z) = |z|^4 - |z|^2$

(b) $g(z) = \frac{\bar{z}}{z^2 + 1}$

(c) $h(z) = z(\bar{z}^2 - z)$

(d) $k(z) = \bar{z} \cdot (\sin z) \cdot (\cos \bar{z})$

3. For each function f , calculate $\partial f / \partial z$:

(a) $2z(1 - z^3)$

(b) $(\cos z) \cdot (1 + \sin^2 z)$

(c) $(\sin \bar{z})(1 + \bar{z} \cos z)$

(d) $|z|^4 - |z|^2$

4. For each function g , calculate $\partial g / \partial \bar{z}$:

(a) $2\bar{z}(1 - z^3)$

(b) $(\sin \bar{z}) \cdot (1 + \sin^2 \bar{z})$

(c) $(\cos z) \cdot (1 + z \cos \bar{z})$

(d) $|z|^2 - |z|^4$

5. Verify the equations

$$\frac{\partial}{\partial z} z = 1, \quad \frac{\partial}{\partial z} \bar{z} = 0,$$

$$\frac{\partial}{\partial \bar{z}} z = 0, \quad \frac{\partial}{\partial \bar{z}} \bar{z} = 1.$$

6. Show that, in polar coordinates, the Cauchy-Riemann equations take the form

$$r \cdot u_r = v_\theta \quad \text{and} \quad r v_r = -u_\theta.$$

Here, of course, subscripts denote derivatives.

7. It is known that the solution y of a second order, linear ordinary differential equation with constant coefficients and satisfying $y(0) = 1$ and $y'(0) = i$ is unique. Let the differential equation be $y'' = -y$. Verify that the function $f(x) = e^{ix}$ satisfies all three conditions. Also verify that the function $g(x) = \cos x + i \sin x$ satisfies all three conditions. By uniqueness, $f(x) \equiv g(x)$. That gives another proof of Euler's formula.
8. Both of the expressions $f(x) = e^{ix}$ and $g(x) = \cos x + i \sin x$ take the value 1 at 0. Also both expressions are invariant under rotations in a certain sense. From this it must follow that $f \equiv g$. This gives another proof of Euler's formula. Fill in the details of this argument.
9. Calculate the derivative

$$\frac{\partial}{\partial z} [\tan z - e^{3z}].$$

10. Calculate the derivative

$$\frac{\partial}{\partial \bar{z}} [\sin \bar{z} - z\bar{z}^2].$$

11. Find a function g such that

$$\frac{\partial g}{\partial z} = z\bar{z}^2 - \sin z.$$

12. Find a function h such that

$$\frac{\partial h}{\partial \bar{z}} = \bar{z}^2 z^3 + \cos \bar{z}.$$

13. Find a function k such that

$$\frac{\partial^2 k}{\partial z \partial \bar{z}} = |z|^2 - \sin z + \bar{z}^3.$$

14. From the definition (line (2.13)), calculate

$$\frac{d}{dz} (z^3 - \bar{z}^2).$$

15. From the definition (line (2.13)), calculate

$$\frac{d}{dz}(\sin z - e^z).$$

16. The software `MatLab` does not know the partial differential operators

$$\frac{\partial}{\partial z} \quad \text{and} \quad \frac{\partial}{\partial \bar{z}}.$$

But you may define `MatLab` functions (see [PRA, p. 35]) to calculate them as follows:

```
function [zderiv] = ddz(f,x,y,z)

syms x y real;
syms z complex;

z = x + i*y;

z_deriv = (diff(f, 'x'))/2 - (diff(f, 'y'))*i/2
```

and

```
function [zbardderiv] = ddzbar(f)

syms x y real;
syms z complex;

z = x + i*y;

zbar_deriv = (diff(f, 'x'))/2 + (diff(f, 'y'))*i/2
```

You must give the first macro file the name `ddz.m` and the second macro file the name `ddzbar.m`. With these macros in place you can proceed as follows. At the `MatLab` prompt `>>`, type these commands (following each one by `<Enter>`):

```
>> syms x y real
>> syms z complex
>> z = x + i*y
```

This gives **MatLab** the information it needs in order to do complex calculus. Now let us define a function:

```
>> f = z^2
```

Finally type `ddz(f)` and press `<Enter>`. **MatLab** will produce an answer (that is equivalent to) `2*(x + iy)`. What you have just done is differentiated z^2 with respect to z and obtained the answer $2z$. If instead you type, at the **MatLab** prompt, `ddzbar(f)`, you will obtain an answer (that is equivalent to) `0`. That is because the macro `ddzbar` performs differentiation with respect to \bar{z} .

For practice, use your new **MatLab** macros to calculate several other complex derivatives. [Remember that the **MatLab** command for \bar{z} is `conj(z)`.] For example, try

$$\frac{\partial}{\partial z} z^2 \cdot \bar{z}^3, \quad \frac{\partial}{\partial z} \sin(z \cdot \bar{z}), \quad \frac{\partial}{\partial \bar{z}} \cos(z^2 \cdot \bar{z}^3), \quad \frac{\partial}{\partial \bar{z}} e^{z \cdot \bar{z}^2}.$$

17. The function $f(z) = z^2 - z^3$ is holomorphic. Why? It has real part u that describes a steady state flow of heat on the unit disc. Calculate this real part. Verify that u satisfies the partial differential equation

$$\frac{\partial}{\partial z} \frac{\partial}{\partial \bar{z}} u(z) \equiv 0.$$

This is the *Laplace equation*. We shall study it in greater detail as the book progresses.

18. Do the last exercise with “real part” u replaced by “imaginary part” v .

2.2 The Relationship of Holomorphic and Harmonic Functions

2.2.1 Harmonic Functions

A C^2 (twice continuously differentiable) function u is said to be *harmonic* if it satisfies the equation

$$\left(\frac{\partial^2}{\partial x^2} + \frac{\partial^2}{\partial y^2} \right) u = 0. \quad (2.18)$$

This partial differential equation is called *Laplace's equation*, and is frequently abbreviated as

$$\Delta u = 0. \quad (2.19)$$

EXAMPLE 22 The function $u(x, y) = x^2 - y^2$ is harmonic. This assertion may be verified directly:

$$\Delta u = \left(\frac{\partial^2}{\partial x^2} + \frac{\partial^2}{\partial y^2} \right) u = \left(\frac{\partial^2}{\partial x^2} \right) x^2 - \left(\frac{\partial^2}{\partial y^2} \right) y^2 = 2 - 2 = 0.$$

A similar calculation shows that $v(x, y) = 2xy$ is harmonic. For

$$\Delta v = \left(\frac{\partial^2}{\partial x^2} + \frac{\partial^2}{\partial y^2} \right) 2xy = 0 + 0 = 0.$$

□

EXAMPLE 23 The function $\tilde{u}(x, y) = x^3$ is *not* harmonic. For

$$\Delta \tilde{u} = \left(\frac{\partial^2}{\partial x^2} + \frac{\partial^2}{\partial y^2} \right) u = \left(\frac{\partial^2}{\partial x^2} + \frac{\partial^2}{\partial y^2} \right) x^3 = 6x \neq 0.$$

Likewise, the function $\tilde{v}(x, y) = \sin x - \cos y$ is *not* harmonic. For

$$\Delta \tilde{v} = \left(\frac{\partial^2}{\partial x^2} + \frac{\partial^2}{\partial y^2} \right) \tilde{v} = \left(\frac{\partial^2}{\partial x^2} + \frac{\partial^2}{\partial y^2} \right) [\sin x - \cos y] = -\sin x + \cos y \neq 0.$$

□

2.2.2 Holomorphic and Harmonic Functions

If f is a holomorphic function and $f = u + iv$ is the expression of f in terms of its real and imaginary parts, then both u and v are harmonic. The easiest way to see this is to begin with the equation

$$\frac{\partial}{\partial \bar{z}} f = 0 \quad (2.20)$$

and to apply $\partial/\partial z$ to both sides. The result is

$$\frac{\partial}{\partial z} \frac{\partial}{\partial \bar{z}} f = 0 \quad (2.21)$$

or

$$\left(\frac{1}{2} \left[\frac{\partial}{\partial x} - i \frac{\partial}{\partial y} \right] \right) \left(\frac{1}{2} \left[\frac{\partial}{\partial x} + i \frac{\partial}{\partial y} \right] \right) [u + iv] = 0. \quad (2.22)$$

Multiplying through by 4, and then multiplying out the derivatives, we find that

$$\left(\frac{\partial^2}{\partial x^2} + \frac{\partial^2}{\partial y^2} \right) [u + iv] = 0. \quad (2.23)$$

We may now distribute the differentiation and write this as

$$\left(\frac{\partial^2}{\partial x^2} + \frac{\partial^2}{\partial y^2} \right) u + i \left(\frac{\partial^2}{\partial x^2} + \frac{\partial^2}{\partial y^2} \right) v = 0. \quad (2.24)$$

The only way that the left-hand side can be zero is if its real part is zero and its imaginary part is zero. We conclude then that

$$\left(\frac{\partial^2}{\partial x^2} + \frac{\partial^2}{\partial y^2} \right) u = 0 \quad (2.25)$$

and

$$\left(\frac{\partial^2}{\partial x^2} + \frac{\partial^2}{\partial y^2} \right) v = 0. \quad (2.26)$$

Thus u and v are each harmonic.

EXAMPLE 24 Let $f(z) = (z + z^2)^2$. Then f is certainly holomorphic because it is defined using only z s, and no \bar{z} s. Notice that

$$\begin{aligned} f(z) &= z^4 + 2z^3 + z^2 \\ &= [x^4 - 6x^2y^2 + y^4 + 2x^3 - 6xy^2 + x^2 - y^2] \\ &\quad + i[-4xy^3 + 4x^3y + 6x^2y - 2y^3 + 2xy] \\ &\equiv u + iv. \end{aligned}$$

We may check directly that

$$\Delta u = 0 \quad \text{and} \quad \Delta v = 0.$$

Hence the real and imaginary parts of f are each harmonic. \square

A sort of converse to (2.25) and (2.26) is true provided the functions involved are defined on a domain with no holes:

If \mathcal{R} is an open rectangle (or open disc) and if u is a real-valued harmonic function on \mathcal{R} , then there is a holomorphic function F on \mathcal{R} such that $\operatorname{Re} F = u$. In other words, for such a function u there exists another harmonic function v defined on \mathcal{R} such that $F \equiv u + iv$ is holomorphic on \mathcal{R} . Any two such functions v must differ by a real constant.

More generally, if U is a region with no holes (a *simply connected* region—see Section 3.1.4), and if u is harmonic on U , then there is a holomorphic function F on U with $\operatorname{Re} F = u$. In other words, for such a function u there exists a harmonic function v defined on U such that $F \equiv u + iv$ is holomorphic on U . Any two such functions v must differ by a constant. We call the function v a *harmonic conjugate* for u .

The displayed statement is false on a domain with a hole, such as an annulus. For example, the harmonic function $u = \log(x^2 + y^2)$, defined on the annulus $U = \{z : 1 < |z| < 2\}$, has no harmonic conjugate on U . See also Section 2.2.2. Let us give an example to illustrate the notion of harmonic conjugate, and then we shall discuss why the displayed statement is true.

EXAMPLE 25 Consider the function $u(x, y) = x^2 - y^2 - x$ on the square $U = \{(x, y) : |x| < 1, |y| < 1\}$. Certainly U is simply connected. And one may verify directly that $\Delta u \equiv 0$ on U . To solve for v a harmonic conjugate of u , we use the Cauchy-Riemann equations:

$$\begin{aligned} \frac{\partial v}{\partial y} &= \frac{\partial u}{\partial x} = 2x - 1, \\ \frac{\partial v}{\partial x} &= -\frac{\partial u}{\partial y} = 2y. \end{aligned}$$

The first of these equations indicates that $v(x, y) = 2xy - y + \varphi(x)$, for some unknown function $\varphi(x)$. Then

$$2y = \frac{\partial v}{\partial x} = 2y - \varphi'(x).$$

It follows that $\varphi'(x) = 0$ so that $\varphi(x) \equiv C$ for some real constant C .

In conclusion,

$$v(x, y) = 2xy - y + C.$$

In other words, $h(x, y) = u(x, y) + iv(x, y) = [x^2 - y^2 - x] + i[2xy - y + C]$ should be holomorphic. We may verify this claim immediately by writing h as

$$h(z) = z^2 - z + iC.$$

□

You may also verify that the function h in the last example is holomorphic by checking the Cauchy-Riemann equations.

We may verify the displayed statement above just by using multivariable calculus. Suppose that U is a region with no holes and u is a harmonic function on U . We wish to solve the system of equations

$$\begin{aligned} \frac{\partial v}{\partial x} &= -\frac{\partial u}{\partial y} \\ \frac{\partial v}{\partial y} &= \frac{\partial u}{\partial x}. \end{aligned} \tag{2.27}$$

These are the Cauchy-Riemann equations.

Now we know from calculus that this system of equations can be solved on U precisely when

$$\frac{\partial}{\partial y} \left[-\frac{\partial u}{\partial y} \right] = \frac{\partial}{\partial x} \left[\frac{\partial u}{\partial x} \right],$$

that is, when

$$\frac{\partial^2 u}{\partial x^2} + \frac{\partial^2 u}{\partial y^2} = 0.$$

Thus we see that we can solve the required system of equations (2.27) provided only that u is harmonic. Of course we are *assuming* that u is harmonic. Thus the system (2.27) gives us the needed function v , and (2.27) also guarantees that $F = u + iv$ is holomorphic as desired.

Exercises

1. Verify that each of these functions is harmonic:

(a) $f(z) = \operatorname{Re} z$

(b) $g(z) = x^3 - 3xy^2$

(c) $h(z) = |z|^2 - 2x^2$

(d) $k(z) = e^x \cos y$

2. Verify that each of these functions is *not* harmonic:

(a) $f(z) = |z|^2$

(b) $g(z) = |z|^4 - |z|^2$

(c) $h(z) = \bar{z} \sin z$

(d) $k(z) = e^{\bar{z} \cos z}$

3. For each of these (real-valued) harmonic functions u , find a (real-valued) harmonic function v such that $u + iv$ is holomorphic.

(a) $u(z) = e^x \sin y$

(b) $u(z) = 3x^2y - y^3$

(c) $u(z) = e^{2y} \sin x \cos x$

(d) $u(z) = x - y$

4. Use the chain rule to express the Laplace operator Δ in terms of polar coordinates (r, θ) .

5. Let $\rho(x, y)$ be a rotation of the plane. Thus ρ is given by a 2×2 matrix with each row a unit vector and the two rows orthogonal to each other. Further, the determinant of the matrix is 1. Prove that, for any C^2 function f ,

$$\Delta(f \circ \rho) = (\Delta f) \circ \rho.$$

6. Let $a \in \mathbb{R}^2$ and let λ_a be the operator $\lambda_a(x, y) = (x, y) + a$. This is translation by a . Verify that, for any C^2 function f ,

$$\Delta(f \circ \lambda_a) = (\Delta f) \circ \lambda_a.$$

7. A function u is *biharmonic* if $\Delta^2 u = 0$. Verify that the function $x^4 - y^4$ is biharmonic. Give two distinct other examples of non-constant biharmonic functions. [Note that biharmonic functions are useful in the study of charge-transfer reactions in physics.]
8. Calculate the real and imaginary parts of the holomorphic function

$$f(z) = z^2 \cos z - e^{z^3 - z}$$

and verify directly that each of these functions is harmonic.

9. Create a `MatLab` function, called `lap1`, that will calculate the Laplacian of a given function. [**Hint:** You will find it useful to know that the `MatLab` command `diff(f, 'x', 2)` differentiates the function f two times in the x variable.] Your macro should calculate the Laplacian of a function whether it is expressed in terms of x, y or z, \bar{z} . Use your macro to calculate the Laplacians of these functions

$$f(x, y) = x^2 + y^2, \quad f(x, y) = x^2 - y^2, \quad f(x, y) = e^x \cdot \cos y, \quad f(x, y) = e^{-y} \cdot \sin x,$$

$$g(z) = z \cdot \bar{z}^2, \quad g(z) = \frac{z}{\bar{z}}, \quad g(z) = z^2 - \bar{z}^2.$$

10. Consider a unit disc made of some heat-conducting metal like aluminum. Imagine an initial heat distribution φ on the boundary of this disc, and let the heat flow to the interior of the disc. The *steady state heat distribution* turns out to be a harmonic function $u(x, y)$ with boundary function φ . We shall study this matter in greater detail in Chapter 8. See also Chapter 9.

Suppose that $\varphi(e^{it}) = \cos 2t$. Determine what u must be. [**Hint:** Consider the function $\Phi(e^{it}) = \cos 2t + i \sin 2t = e^{2it}$.]

Now answer the same question for $\varphi(e^{it}) = \sin 3t$.

2.3 Real and Complex Line Integrals

In this section we shall recast the line integral from multivariable calculus in complex notation. The result will be the complex line integral.

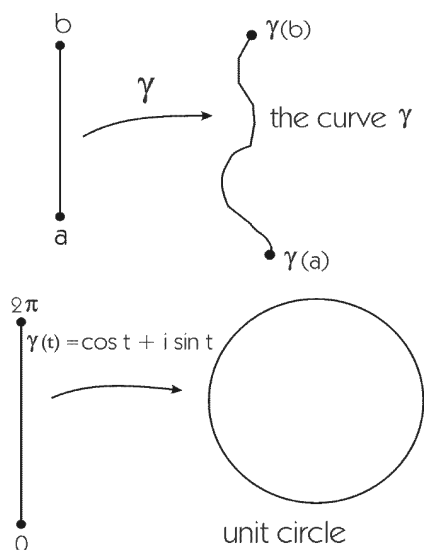


Figure 2.2: Two curves in the plane, one closed.

2.3.1 Curves

It is convenient to think of a *curve* as a (continuous) function γ from a closed interval $[a, b] \subseteq \mathbb{R}$ into $\mathbb{R}^2 \approx \mathbb{C}$. In practice it is useful *not* to distinguish between the *function* γ and the image (or set of points that make up the curve) given by $\{\gamma(t) : t \in [a, b]\}$. In the case that $\gamma(a) = \gamma(b)$, then we say that the curve is *closed*. Refer to Figure 2.2.

It is often convenient to write

$$\gamma(t) = (\gamma_1(t), \gamma_2(t)) \quad \text{or} \quad \gamma(t) = \gamma_1(t) + i\gamma_2(t). \quad (2.28)$$

For example, $\gamma(t) = (\cos t, \sin t) = \cos t + i \sin t$, $t \in [0, 2\pi]$, describes the unit circle in the plane. The circle is traversed in a counterclockwise manner as t increases from 0 to 2π . This curve is closed. Refer to Figure 2.3.

2.3.2 Closed Curves

We have already noted that the curve $\gamma : [a, b] \rightarrow \mathbb{C}$ is called *closed* if $\gamma(a) = \gamma(b)$. It is called *simple, closed* (or *Jordan*) if the restriction of γ to the interval $[a, b)$ (which is commonly written $\gamma|_{[a, b)}$) is one-to-one *and*

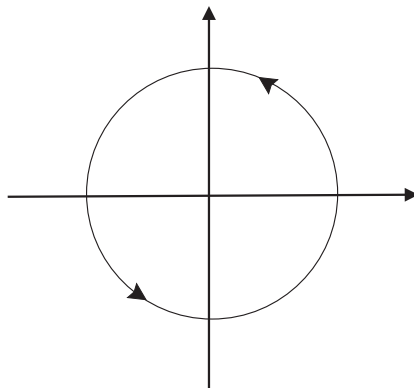


Figure 2.3: A simple, closed curve.

$\gamma(a) = \gamma(b)$ (Figures 2.3, 2.4). Intuitively, a simple, closed curve is a curve with no self-intersections, except of course for the closing up at $t = a, b$.

In order to work effectively with γ we need to impose on it some differentiability properties.

2.3.3 Differentiable and C^k Curves

A function $\varphi : [a, b] \rightarrow \mathbb{R}$ is called *continuously differentiable* (or C^1), and we write $\varphi \in C^1([a, b])$, if

- (2.29) φ is continuous on $[a, b]$;
- (2.30) φ' exists on (a, b) ;
- (2.31) φ' has a continuous extension to $[a, b]$.

In other words, we require that

$$\lim_{t \rightarrow a^+} \varphi'(t) \quad \text{and} \quad \lim_{t \rightarrow b^-} \varphi'(t) \quad (2.32)$$

both exist.

Note that, under these circumstances,

$$\varphi(b) - \varphi(a) = \int_a^b \varphi'(t) dt, \quad (2.33)$$

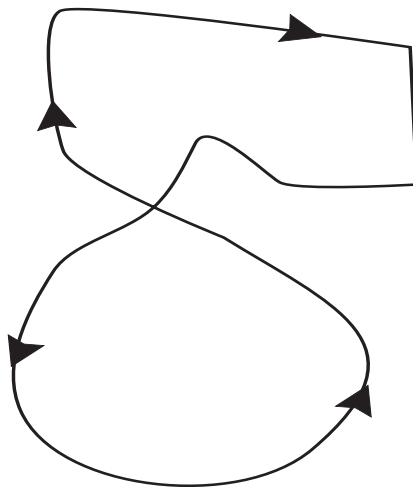


Figure 2.4: A closed curve that is not simple.

so that the Fundamental Theorem of Calculus holds for $\varphi \in C^1([a, b])$.

A curve $\gamma : [a, b] \rightarrow \mathbb{C}$, with $\gamma(t) = \gamma_1(t) + i\gamma_2(t)$ is said to be *continuous* on $[a, b]$ if both γ_1 and γ_2 are. The curve is *continuously differentiable* (or C^1) on $[a, b]$, and we write

$$\gamma \in C^1([a, b]), \quad (2.34)$$

if γ_1, γ_2 are continuously differentiable on $[a, b]$. Under these circumstances we will write

$$\frac{d\gamma}{dt} = \frac{d\gamma_1}{dt} + i \frac{d\gamma_2}{dt}. \quad (2.35)$$

We also sometimes write $\gamma'(t)$ or $\dot{\gamma}(t)$ for $d\gamma/dt$.

2.3.4 Integrals on Curves

Let $\psi : [a, b] \rightarrow \mathbb{C}$ be continuous on $[a, b]$. Write $\psi(t) = \psi_1(t) + i\psi_2(t)$. Then we define

$$\int_a^b \psi(t) dt \equiv \int_a^b \psi_1(t) dt + i \int_a^b \psi_2(t) dt \quad (2.36)$$

We summarize the ideas presented thus far by noting that, if $\gamma \in C^1([a, b])$

is complex-valued, then

$$\gamma(b) - \gamma(a) = \int_a^b \gamma'(t) dt. \quad (2.37)$$

2.3.5 The Fundamental Theorem of Calculus along Curves

Now we state the Fundamental Theorem of Calculus (see [BLK]) along curves.

Let $U \subseteq \mathbb{C}$ be a domain and let $\gamma : [a, b] \rightarrow U$ be a C^1 curve. If $f \in C^1(U)$, then

$$f(\gamma(b)) - f(\gamma(a)) = \int_a^b \left(\frac{\partial f}{\partial x}(\gamma(t)) \cdot \frac{d\gamma_1}{dt} + \frac{\partial f}{\partial y}(\gamma(t)) \cdot \frac{d\gamma_2}{dt} \right) dt. \quad (2.38)$$

Note that this formula is a part of calculus, *not* complex analysis.

2.3.6 The Complex Line Integral

When f is holomorphic, then formula (2.38) may be rewritten (using the Cauchy-Riemann equations) as

$$f(\gamma(b)) - f(\gamma(a)) = \int_a^b \frac{\partial f}{\partial z}(\gamma(t)) \cdot \frac{d\gamma}{dt}(t) dt, \quad (2.39)$$

where, as earlier, we have taken $d\gamma/dt$ to be $d\gamma_1/dt + id\gamma_2/dt$. The reader may write out the right-hand side of (2.39) and see that it agrees with (2.38).

This latter result plays much the same role for holomorphic functions as does the Fundamental Theorem of Calculus for functions from \mathbb{R} to \mathbb{R} . The expression on the right of (2.39) is called the *complex line integral of $\partial f/\partial z$ along γ* and is denoted

$$\oint_{\gamma} \frac{\partial f}{\partial z}(z) dz. \quad (2.40)$$

The small circle through the integral sign \oint tells us that this is a complex line integral, and has the meaning (2.39).

More generally, if g is *any* continuous function (not necessarily holomorphic) whose domain contains the curve γ , then the complex line integral of

g along γ is defined to be

$$\oint_{\gamma} g(z) dz \equiv \int_a^b g(\gamma(t)) \cdot \frac{d\gamma}{dt}(t) dt. \quad (2.41)$$

This is the *complex line integral of g along γ* . Compare with line (2.39).

EXAMPLE 26 Let $f(z) = z^2 - 2z$ and let $\gamma(t) = (\cos t, \sin t) = \cos t + i \sin t$, $0 \leq t \leq \pi$. Then $\gamma'(t) = -\sin t + i \cos t$. This curve γ traverses the upper half of the unit circle from the initial point $(1, 0)$ to the terminal point $(-1, 0)$. We may calculate that

$$\begin{aligned} \oint_{\gamma} f(z) dz &= \int_0^{\pi} f(\cos t + i \sin t) \cdot (-\sin t + i \cos t) dt \\ &= \int_0^{\pi} [(\cos t + i \sin t)^2 - 2(\cos t + i \sin t)] \cdot (-\sin t + i \cos t) dt \\ &= \int_0^{\pi} 4 \cos t \sin t - 3 \sin t \cos^2 t - 2i \cos 2t \\ &\quad - 3i \sin^2 t \cos t + \sin^3 t + i \cos^3 t dt \\ &= \left[2 \sin^2 t + \cos^3 t - i \sin 2t - i \sin^3 t \right. \\ &\quad \left. - \cos t + i \sin t + \frac{\cos^3 t}{3} - i \frac{\sin^3 t}{3} \right]_0^{\pi} \\ &= -\frac{2}{3}. \end{aligned}$$

□

EXAMPLE 27 If we integrate the holomorphic function f from the last example around the closed curve $\eta(t) = (\cos t, \sin t)$, $0 \leq t \leq 2\pi$, then we

obtain

$$\begin{aligned}
 \oint_{\eta} f(z) dz &= \int_0^{2\pi} f(\cos t + i \sin t) \cdot (-\sin t + i \cos t) dt \\
 &= \int_0^{2\pi} [(\cos t + i \sin t)^2 - 2(\cos t + i \sin t)] \cdot (-\sin t + i \cos t) dt \\
 &= \int_0^{2\pi} 4 \cos t \sin t - 3 \sin t \cos^2 t - 2i \cos 2t \\
 &\quad - 3i \sin^2 t \cos t + \sin^3 t + i \cos^3 t dt \\
 &= \left[2 \sin^2 t + \cos^3 t - i \sin 2t - i \sin^3 t \right. \\
 &\quad \left. - \cos t + i \sin t + \frac{\cos^3 t}{3} - \frac{\sin^3 t}{3} \right]_0^{2\pi} \\
 &= 0.
 \end{aligned}$$

□

The whole concept of complex line integral is central to our further considerations in later sections. We shall use integrals like the one on the right of (2.39) or (2.41) even when f is not holomorphic; but we can be sure that the equality (2.39) holds *only when* f is holomorphic.

EXAMPLE 28 Let $g(z) = |z|^2$ and let $\mu(t) = t + it$, $0 \leq t \leq 1$. Let us calculate

$$\oint_{\mu} g(z) dz.$$

We have

$$\oint_{\mu} g(z) dz = \int_0^1 g(t + it) \cdot \mu'(t) dt = \int_0^1 2t^2 \cdot (1 + i) dt = \frac{2t^3}{3} (1 + i) \Big|_0^1 = \frac{2 + 2i}{3}.$$

□

2.3.7 Properties of Integrals

We conclude this section with some easy but useful facts about integrals.

(A) If $\varphi : [a, b] \rightarrow \mathbb{C}$ is continuous, then

$$\left| \int_a^b \varphi(t) dt \right| \leq \int_a^b |\varphi(t)| dt.$$

(B) If $\gamma : [a, b] \rightarrow \mathbb{C}$ is a C^1 curve and φ is a continuous function on the curve γ , then

$$\left| \oint_{\gamma} \varphi(z) dz \right| \leq \left[\max_{t \in [a, b]} |\varphi(t)| \right] \cdot \ell(\gamma), \quad (2.42)$$

where

$$\ell(\gamma) \equiv \int_a^b |\varphi'(t)| dt$$

is the *length* of γ .

(C) The calculation of a complex line integral is independent of the way in which we parametrize the path:

Let $U \subseteq \mathbb{C}$ be an open set and $F : U \rightarrow \mathbb{C}$ a continuous function. Let $\gamma : [a, b] \rightarrow U$ be a C^1 curve. Suppose that $\varphi : [c, d] \rightarrow [a, b]$ is a one-to-one, onto, increasing C^1 function with a C^1 inverse. Let $\tilde{\gamma} = \gamma \circ \varphi$. Then

$$\oint_{\tilde{\gamma}} f dz = \oint_{\gamma} f dz.$$

This last statement implies that one can use the idea of the integral of a function f along a curve γ when the curve γ is described geometrically but without reference to a specific parametrization. For instance, “the integral of \bar{z} *counterclockwise* around the unit circle $\{z \in \mathbb{C} : |z| = 1\}$ ” is now a phrase that makes sense, even though we have not indicated a specific parametrization of the unit circle. Note, however, that the direction counts: The integral of \bar{z} counterclockwise around the unit circle is $2\pi i$. If the direction is reversed, then the integral changes sign: The integral of \bar{z} *clockwise* around the unit circle is $-2\pi i$.

EXAMPLE 29 Let $g(z) = z^2 - z$ and $\gamma(t) = t^2 - it$, $0 \leq t \leq 1$. Then

$$\begin{aligned}
 \oint_{\gamma} g(z) dz &= \int_0^1 g(t^2 - it) \cdot \gamma'(t) dt \\
 &= \int_0^1 [(t^2 - it)^2 - (t^2 - it)] \cdot (2t - i) dt \\
 &= \int_0^1 [t^4 - 2it^3 - 2t^2 + it] \cdot (2t - i) dt \\
 &= \int_0^1 2t^5 - 5it^4 - 6t^3 + 4it^2 + t dt \\
 &= \left[\frac{2t^6}{6} - \frac{5it^5}{5} - \frac{6t^4}{4} + \frac{4it^3}{3} + \frac{t^2}{2} \right]_0^1 \\
 &= \frac{1}{3} - i - \frac{3}{2} + \frac{4i}{3} + \frac{1}{2} \\
 &= -\frac{2}{3} + \frac{i}{3}.
 \end{aligned}$$

If instead we replace γ by $-\gamma$ (which amounts to parametrizing the curve from 1 to 0 instead of from 0 to 1) then we obtain

$$\begin{aligned}
 \oint_{-\gamma} g(z) dz &= \int_1^0 g(t^2 - it) \cdot \gamma'(t) dt \\
 &= \int_1^0 [(t^2 - it)^2 - (t^2 - it)] \cdot (2t - i) dt \\
 &= \int_1^0 [t^4 - 2it^3 - 2t^2 + it] \cdot (2t - i) dt \\
 &= \int_1^0 2t^5 - 5it^4 - 6t^3 + 4it^2 + t dt \\
 &= \left[\frac{2t^6}{6} - \frac{5it^5}{5} - \frac{6t^4}{4} + \frac{4it^3}{3} + \frac{t^2}{2} \right]_1^0 \\
 &= -\left(\frac{1}{3} - i - \frac{3}{2} + \frac{4i}{3} + \frac{1}{2} \right) \\
 &= \frac{2}{3} - \frac{i}{3}.
 \end{aligned}$$

□

Exercises

1. In each of the following problems, calculate the complex line integral of the given function f along the given curve γ :

(a) $f(z) = z\bar{z}^2 - \cos z$, $\gamma(t) = \cos 2t + i \sin 2t$, $0 \leq t \leq \pi/2$

(b) $f(z) = \bar{z}^2 - \sin z$, $\gamma(t) = t + it^2$, $0 \leq t \leq 1$

(c) $f(z) = z^3 + \frac{z}{z+1}$, $\gamma(t) = e^t + ie^{2t}$, $1 \leq t \leq 2$

(d) $f(z) = e^z - e^{-z}$, $\gamma(t) = t - i \log t$, $1 \leq t \leq e$

2. Calculate the complex line integral of the holomorphic function $f(z) = z^2$ along the counterclockwise-oriented square of side 2, with sides parallel to the axes, centered at the origin.
3. Calculate the complex line integral of the function $g(z) = 1/z$ along the counterclockwise-oriented square of side 2, with sides parallel to the axes, centered at the origin.
4. Calculate the complex line integral of the holomorphic function $f(z) = z^k$, $k = 0, 1, 2, \dots$, along the curve $\gamma(t) = \cos t + i \sin t$, $0 \leq t \leq \pi$. Now calculate the complex line integral of the same function along the curve $\mu(t) = \cos t - i \sin t$, $0 \leq t \leq \pi$. Verify that, for each fixed k , the two answers are the same.
5. Verify that the conclusion of the last exercise is *false* if we take $k = -1$.
6. Verify that the conclusion of Exercise 4 is still true if we take $k = -2, -3, -4, \dots$.
7. Suppose that f is a continuous function with complex antiderivative F . This means that $\partial F / \partial z = f$ on the domain of definition. Let γ be a continuously differentiable, closed curve in the domain of f . Prove that

$$\oint_{\gamma} f(z) dz = 0.$$

8. If f is a function and γ is a curve and $\oint_{\gamma} f(z) dz = 0$ then does it follow that $\oint f^2(z) dz = 0$?
9. Use the script

```

function [w] = cplxln(f,g,a,b)

syms t real;
syms z complex;

gd = diff(g, 't');

fg = subs(f, z, g);

xyz = fg*gd;

cplxlineint = int(xyz,t,a,b)

```

to create a function that calculates the complex line integral of the complex function f over the curve parametrized by g . Notice the following:

- The complex function is called f ;
- The curve is $g : [a, b] \rightarrow \mathbb{C}$.
- The file must be called `cplxln.m`.

After you have this code entered and the file installed, test it out by entering

```

>> syms t real;
>> syms z complex;
>> f = z^2
>> g = cos(t) + i*sin(t)
>> a = 0
>> b = 2*pi
>> cplxln(f,g,a,b)

```

Notice that we are entering the function $f(z) = z^2$ and integrating over the curve $g : [0, 2\pi] \rightarrow \mathbb{C}$ given by $g(t) = \cos t + i \sin t$. You should obtain the answer 0 because the f that you have entered is holomorphic.

Now try `f = conj(z)`. This time you will obtain the answer `2*pi*i` because f is now the conjugate holomorphic function \bar{z} . Finally, apply

the function cplxln to the function $f = 1/z$ on the same curve. What answer do you obtain? Why?

10. If \mathbf{F} is a vector field in the plane and γ a curve then $\int_{\gamma} \mathbf{F} \, d\mathbf{r}$ represents the work performed while traveling along the curve and resisting the force \mathbf{F} . Interpret the complex line integral in this language.

2.4 Complex Differentiability and Conformality

2.4.1 Conformality

Now we make some remarks about “conformality.” Stated loosely, a function is *conformal* at a point $P \in \mathbb{C}$ if the function “preserves angles” at P and “stretches equally in all directions” at P . Both of these statements must be interpreted infinitesimally; we shall learn to do so in the discussion below. Holomorphic functions enjoy both properties:

Let f be holomorphic in a neighborhood of $P \in \mathbb{C}$. Let w_1, w_2 be complex numbers of unit modulus. Consider the directional derivatives

$$D_{w_1} f(P) \equiv \lim_{t \rightarrow 0} \frac{f(P + tw_1) - f(P)}{t} \quad (2.43)$$

and

$$D_{w_2} f(P) \equiv \lim_{t \rightarrow 0} \frac{f(P + tw_2) - f(P)}{t}. \quad (2.44)$$

Then

$$(2.45) \quad |D_{w_1} f(P)| = |D_{w_2} f(P)|.$$

$$(2.46) \quad \text{If } |f'(P)| \neq 0, \text{ then the directed angle from } w_1 \text{ to } w_2 \text{ equals the directed angle from } D_{w_1} f(P) \text{ to } D_{w_2} f(P).$$

Statement (2.45) is the analytical formulation of “stretching equally in all directions.” Statement (2.46) is the analytical formulation of “preserves angles.”

In fact let us now give a discursive description of why conformality works. Either of these two properties actually characterizes holomorphic functions.

It is worthwhile to picture the matter in the following manner: Let f be holomorphic on the open set $U \subseteq \mathbb{C}$. Fix a point $P \in U$. Write $f = u + iv$ as usual. Thus we may write the mapping f as $(x, y) \mapsto (u, v)$. Then the (real) Jacobian matrix of the mapping is

$$J(P) = \begin{pmatrix} u_x(P) & u_y(P) \\ v_x(P) & v_y(P) \end{pmatrix},$$

where subscripts denote derivatives. We may use the Cauchy-Riemann equations to rewrite this matrix as

$$J(P) = \begin{pmatrix} u_x(P) & u_y(P) \\ -u_y(P) & u_x(P) \end{pmatrix}$$

Factoring out a numerical coefficient, we finally write this two-dimensional derivative as

$$\begin{aligned} J(P) &= \sqrt{u_x(P)^2 + u_y(P)^2} \cdot \begin{pmatrix} \frac{u_x(P)}{\sqrt{u_x(P)^2 + u_y(P)^2}} & \frac{u_y(P)}{\sqrt{u_x(P)^2 + u_y(P)^2}} \\ \frac{-u_y(P)}{\sqrt{u_x(P)^2 + u_y(P)^2}} & \frac{u_x(P)}{\sqrt{u_x(P)^2 + u_y(P)^2}} \end{pmatrix} \\ &\equiv h(P) \cdot \mathcal{J}(P). \end{aligned}$$

The matrix $\mathcal{J}(P)$ is of course a special orthogonal matrix (that is, its rows form an orthonormal basis of \mathbb{R}^2 , and it is oriented positively—so it has determinant 1). Of course a special orthogonal matrix represents a *rotation*. Thus we see that the derivative of our mapping is a rotation $\mathcal{J}(P)$ (which preserves angles) followed by a positive “stretching factor” $h(P)$ (which also preserves angles). Of course a rotation stretches equally in all directions (in fact it does not stretch at all); and our stretching factor, or dilation, stretches equally in all directions (it simply multiplies by a positive factor). So we have established (2.45) and (2.46).

In fact the second characterization of conformality (in terms of preservation of directed angles) has an important converse: If (2.46) holds at points near P , then f has a complex derivative at P . If (2.45) holds at points near P , then either f or \bar{f} has a complex derivative at P . Thus a function that is conformal (in either sense) at all points of an open set U must possess the complex derivative at each point of U . By the discussion in Section 2.1.6,

the function f is therefore holomorphic if it is C^1 . Or, by Goursat's theorem, it would then follow that the function is holomorphic on U , with the C^1 condition being automatic.

Exercises

1. Consider the holomorphic function $f(z) = z^2$. Calculate the derivative of f at the point $P = 1 + i$. Write down the Jacobian matrix of f at P , thought of as a 2×2 real matrix operator. Verify directly (by imitating the calculations presented in this section) that this Jacobian matrix is the composition of a special orthogonal matrix and a dilation.
2. Repeat the first exercise with the function $g(z) = \sin z$ and $P = \pi + (\pi/2)i$.
3. Repeat the first exercise with the function $h(z) = e^z$ and $P = 2 - i$.
4. Discuss, in physical language, why the surface motion of an incompressible fluid flow should be conformal.
5. Verify that the function $g(z) = \bar{z}^2$ has the property that (at all points not equal to 0) it stretches equally in all directions, but it reverses angles. We say that such a function is *anticonformal*.
6. The function $h(z) = z + 2\bar{z}$ is *not* conformal. Explain why.
7. If a continuously differentiable function is conformal then it is holomorphic. Explain why.
8. If f is conformal then any positive integer power of f is conformal. Explain why.
9. If f is conformal then e^f is conformal. Explain why.
10. Let $\Omega \subseteq \mathbb{C}$ is a domain and $\varphi : \Omega \rightarrow \mathbb{R}$ is a function. Explain why φ , no matter how smooth or otherwise well behaved, could not possibly be conformal.
11. Use the following script to create a `MatLab` function that will detect whether a given complex function is acting conformally:

```

function [conformal_map] = conf(f,v1,v2,P)

syms x y cos1 cos2 real
syms z complex

z = x + i*y;

digits(5)

u = real(f);
v = imag(f);

p = real(P);
q = imag(P);

a11 = diff(u, 'x');
a12 = diff(u, 'y');
a21 = diff(v, 'x');
a22 = diff(v, 'y');

aa11 = subs(a11, {x,y}, {p,q});
aa12 = subs(a12, {x,y}, {p,q});
aa21 = subs(a21, {x,y}, {p,q});
aa22 = subs(a22, {x,y}, {p,q});

A = [aa11 aa12 ; aa21 aa22];

w1 = A*(v1');
w2 = A*(v2');

d1 = dot(v1,w1);
d2 = dot(v2,w2);
n1 = (dot(v1,v1))^(1/2);
n2 = (dot(v2,v2))^(1/2);
m1 = (dot(w1,w1))^(1/2);
m2 = (dot(w2,w2))^(1/2);

ccos1 = d1/(n1 * m1);

```

```

ccos2 = d2/(n2 * m2);

simplify(ccos1)
simplify(ccos2)

disp('The first number is the cosine of the angle')
disp('between the vector v1 and its image under')
disp('the Jacobian of the mapping.')
disp('      ')
disp('The second number is the cosine of the angle')
disp('between the vector v2 and its image under')
disp('the Jacobian of the mapping.')
disp('      ')
disp('If these numbers are equal then the mapping')
disp('is moving each vector v1 and v2 by the same angle.')
disp('Thus the mapping is acting in a conformal manner.')
disp('      ')
disp('If these numbers are unequal then the mapping')
disp('is moving the vectors v1 and v2 by different angles.')
disp('Thus the mapping is NOT acting in a conformal manner.')

```

This macro file must be called `conf.m`.

Your input for this function will be as follows:

```

>> syms x y real
>> syms z complex
>> z = x + i*y
>> f = z^2
>> v1 = [1 1]
>> v2 = [0 1]
>> P = 3 + 2*i
>> conf(f,v1,v2,P)

```

In this sample input we have used the function $f(z) = z^2$ and vectors $v_1 = \langle 1, 1 \rangle$ and $v_2 = \langle 0, 1 \rangle$. The base point is $P = 3 + 2i$. The `MatLab` output will explain to you how conformality is being measured.

Test this new function macro on these data sets:

- $f(z) = z^3$, $v_1 = \langle 2, 1 \rangle$, $v_2 = \langle 1, 3 \rangle$, $P = 2 + 4i$;

- $f(z) = z \cdot \bar{z}$, $v_1 = \langle 2, 2 \rangle$, $v_2 = \langle 2, 3 \rangle$, $P = 2 - 3i$;
- $f(z) = \bar{z}^2$, $v_1 = \langle 1, 1 \rangle$, $v_2 = \langle 1, 4 \rangle$, $P = 1 - 5i$;
- $f(z) = z$, $v_1 = \langle 1, 1 \rangle$, $v_2 = \langle -1, 3 \rangle$, $P = 1 + 4i$.

12. Let

$$\Phi(x, y) = (x^2 - y^2, 2xy).$$

Let P be the point $(1, 0)$. Calculate the directional derivatives at P of Φ in the directions $\mathbf{w}_1 = (1, 0)$ and $\mathbf{w}_2 = (1/\sqrt{2}, 1/\sqrt{2})$. Confirm that the *magnitudes* of these directional derivatives are the same. This is an instance of conformality. What holomorphic mapping is Φ ?

13. Refer to the preceding exercise. The angle between \mathbf{w}_1 and \mathbf{w}_2 is $\pi/4$. Calculate the angle between the directional derivative of Φ at P in the direction \mathbf{w}_1 and the directional derivative of Φ at P in the direction \mathbf{w}_2 . It should also be $\pi/4$.
14. The surface of an incompressible fluid flow represents conformal motion. An air flow does not. Explain why.

2.5 The Logarithm

It is convenient to record here the basic properties of the complex logarithm.

Let $D = D(0, 1)$ be the unit disc and let f be a nonvanishing, holomorphic function on D . We define, for $z \in D$,

$$\mathcal{F}(z) = \int_0^z \frac{f'(\zeta)}{f(\zeta)} d\zeta.$$

This is understood to be a complex line integral along a path connecting 0 to z . The standard Cauchy theory (see Section 3.1.2) shows that the result is independent of the choice of path. Notice that $\mathcal{F}'(z) = f'(z)/f(z)$.

Now fix attention on the case $f(z) = z + 1$. Let $G(z) = e^z - 1$. And consider $\mathcal{F} \circ G$. We see that

$$(\mathcal{F} \circ G)' = \mathcal{F}'(G(z)) \cdot G'(z) = \frac{1}{e^z} \cdot e^z \equiv 1.$$

We conclude from this that

$$\mathcal{F} \circ G = z + C.$$

By adding a constant to \mathcal{F} (which is easily arranged by moving the base point from 0 to some other element of the disc), we may arrange that $C = 0$. Thus \mathcal{F} is the inverse function for G . In other words

$$\mathcal{F}(z) = \log(z + 1).$$

In sum, we have constructed the logarithm function. It is plainly holomorphic by design.

Another way to think about the logarithm is as follows: Write

$$\log w = \log [|w|e^{i \arg w}] = \log |w| + i \arg w.$$

It follows that

$$\operatorname{Re} \log w = \log |w|$$

and

$$\operatorname{Im} \log w = \arg w.$$

This gives us a concrete way to calculate the logarithm. The circle of ideas is best illustrated with some examples.

EXAMPLE 30 Let us find all complex logarithms of the complex number $z = e$. We have

$$\operatorname{Re} \log e = \log |e| = \log e = 1$$

and

$$\operatorname{Im} \log e = \arg e = 2k\pi.$$

Of course, as we know, the argument function has a built-in ambiguity.

In summary,

$$\log e = 1 + 2k\pi i.$$

□

EXAMPLE 31 Let us find all complex logarithms of the complex number $z = 1 + i$. We note that $|z| = \sqrt{2}$ and $\arg z = \pi/4 + 2k\pi$. As a result,

$$\log z = \log(1 + i) = \log \sqrt{2} + \left[\frac{\pi}{4} + 2k\pi \right] i = \frac{1}{2} \log 2 + \left[\frac{\pi}{4} + 2k\pi \right] i.$$

□

It is frequently convenient to select a particular logarithm from among the infinitely many choices provided by the ambiguity in the argument. The *principal branch* of the logarithm is that for which the argument θ satisfies $0 \leq \theta < 2\pi$. We often denote the principal branch of the logarithm by $\text{Log } z$.

EXAMPLE 32 Let us find the principal branch for the logarithm of $z = -3$. We note that $|z| = 3$ and $\arg z = \pi$. We have selected that value for the argument that lies between 0 and 2π so that we may obtain the principal branch. The result is

$$\log z = \log(-3) = \log 3 + i\pi.$$

□

Of course the logarithm is a useful device for defining powers. Indeed, if z, w are complex numbers then

$$z^w \equiv e^{w \log z}.$$

As an example,

$$i^i = e^i \log i = e^{i(i\pi/2)} = e^{-\pi/2}.$$

Note that we have used the principal branch of the logarithm.

We conclude this section by noting that in each of the three examples we may check our work:

$$e^{1+2k\pi i} = e^1 \cdot e^{2k\pi i} = e;$$

$$e^{\log \sqrt{2} + i[\pi/4 + 2k\pi]} = e^{\log \sqrt{2}} \cdot e^{i[\pi/4 + 2k\pi]} = \sqrt{2} \cdot e^{i\pi/4} = 1 + i;$$

and

$$e^{\log 3 + i\pi} = e^{\log 3} \cdot e^{i\pi} = 3 \cdot (-1) = -3.$$

Exercises

1. Calculate the complex logarithm of each of the following complex numbers:
 - (a) $3 - 3i$
 - (b) $-\sqrt{3} + i$
 - (c) $-\sqrt{2} - \sqrt{2}i$

- (d) $1 - \sqrt{3}i$
 - (e) $-i$
 - (f) $\sqrt{3} - \sqrt{3}i$
 - (g) $-1 + 3i$
 - (h) $2 + 6i$
2. Calculate the principal branch of the logarithm of each of the following complex numbers:
- (a) $2 + 2i$
 - (b) $3 - 3\sqrt{3}i$
 - (c) $-4 + 4i$
 - (d) $-1 - i$
 - (e) $-i$
 - (f) -1
 - (g) $1 + \sqrt{3}i$
 - (h) $-2 - 2\sqrt{2}i$
3. Calculate $(1 + i)^{1-i}$, i^{1-i} , $(1 - i)^i$, and $(-3)^{4-i}$.
4. Write a `MatLab` routine to find the principle branch of the logarithm of a given complex number. Use it to evaluate $\log(2 + 2\sqrt{3}i)$, $\log(4 - 4\sqrt{2}i)$.
5. Explain why there is no well-defined logarithm of the complex number 0.
6. It is not possible to give a succinct, unambiguous definition to the logarithm function on all of $\mathbb{C} \setminus \{0\}$. Explain why. We typically define the logarithm on $\mathbb{C} \setminus \{x + i0 : x \leq 0\}$. Explain why this restricted domain removes any ambiguities.
7. Consider the function $f(z) = \log(\log(\log z))$. For which values of z is this function well defined and holomorphic. Refer to the preceding exercise.

8. Consider the mapping $z \mapsto \log z$ applied to the annulus $A = \{z \in \mathbb{C} : 1 < |z| < e\}$. What is the image of this mapping? What physical interpretation can you give to this mapping? [**Hint:** You may find it useful to consider the inverse mapping, which is an exponential. You may take the domain of the inverse mapping to be an entire vertical strip.]

Chapter 3

The Cauchy Theory

3.1 The Cauchy Integral Theorem and Formula

3.1.1 The Cauchy Integral Theorem, Basic Form

If f is a holomorphic function on an open disc W in the complex plane, and if $\gamma : [a, b] \rightarrow W$ is a C^1 curve in W with $\gamma(a) = \gamma(b)$, then

$$\oint_{\gamma} f(z) dz = 0. \quad (3.1)$$

This is the *Cauchy integral theorem*. It is central and fundamental to the theory of complex functions. All of the principal results about holomorphic functions stem from this simple integral formula. We shall spend a good deal of our time in this text studying the Cauchy theorem and its consequences.

We now indicate a proof of this result. In fact it turns out that the Cauchy integral theorem, properly construed, is little more than a restatement of Green's theorem from calculus. Recall (see [BLK]) that Green's theorem says that if u, v are continuously differentiable on a bounded region U in the plane having C^2 boundary, then

$$\int_{\partial U} u dx + v dy = \iint_U \left(\frac{\partial v}{\partial x} - \frac{\partial u}{\partial y} \right) dx dy. \quad (3.2)$$

In the proof that we are about to present, we shall for simplicity assume that the curve γ is simple, closed. That is, γ does not cross itself, so it

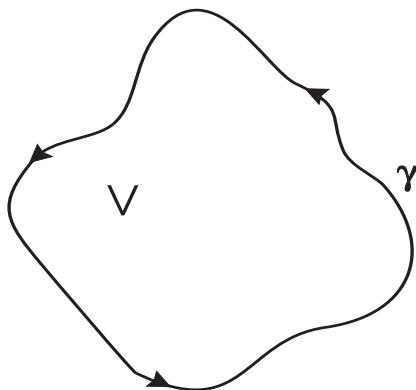


Figure 3.1: The curve γ surrounds the region V .

surrounds a region V . See Figure 3.1. Thus $\gamma = \partial V$. We take γ to be oriented counterclockwise. Let us write

$$\oint_{\gamma} f dz = \oint_{\gamma} (u + iv) [dx + idy] = \left(\oint_{\gamma} u dx - v dy \right) + i \left(\oint_{\gamma} v dx + u dy \right).$$

Each of these integrals is clearly a candidate for application of Green's theorem (3.2). Thus

$$\oint_{\gamma} f dz = \oint_{\partial V} f dz = \iint_V \left(\frac{\partial(-v)}{\partial x} - \frac{\partial u}{\partial y} \right) dx dy + i \iint_V \left(\frac{\partial u}{\partial x} - \frac{\partial v}{\partial y} \right) dx dy.$$

But, according to the Cauchy-Riemann equations, each of the integrands vanishes. We learn then that

$$\oint_{\gamma} f dz = 0.$$

That is Cauchy's theorem.

An important converse of Cauchy's theorem is called *Morera's theorem*:

Let f be a continuous function on a connected open set $U \subseteq \mathbb{C}$.

If

$$\oint_{\gamma} f(z) dz = 0 \tag{3.3}$$

for every simple, closed curve γ in U , then f is holomorphic on U .

In the statement of Morera's theorem, the phrase "every simple, closed curve" may be replaced by "every triangle" or "every square" or "every circle."

The verification of Morera's theorem also uses Green's theorem. Assume for simplicity that f is continuously differentiable. Then the same calculation as above shows that if

$$\oint_{\gamma} f(z) dz = 0$$

for every simple, closed curve γ , then

$$\iint_U \left(\frac{\partial(-v)}{\partial x} - \frac{\partial u}{\partial y} \right) + i \left(\frac{\partial u}{\partial x} - \frac{\partial v}{\partial y} \right) dx dy = 0$$

for the region U that γ surrounds. This is true for every possible region U ! It follows that the integrand must be identically zero. But this simply says that f satisfies the Cauchy-Riemann equations. So it is holomorphic.¹

3.1.2 More General Forms of the Cauchy Theorem

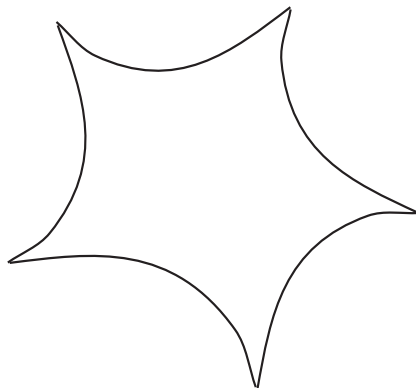
Now we present the very useful general statement of the Cauchy integral theorem. First we need a piece of terminology. A curve $\gamma : [a, b] \rightarrow \mathbb{C}$ is said to be *piecewise C^k* if

$$[a, b] = [a_0, a_1] \cup [a_1, a_2] \cup \cdots \cup [a_{m-1}, a_m] \quad (3.4)$$

with $a = a_0 < a_1 < \cdots < a_m = b$ and the curve $\gamma|_{[a_{j-1}, a_j]}$ is C^k for $1 \leq j \leq m$. In other words, γ is piecewise C^k if it consists of finitely many C^k curves chained end to end. See Figure 3.2.

Piecewise C^k curves will come up both explicitly and implicitly in many of our ensuing discussions. When we deform, and cut and paste, curves then the curves created will often be piecewise C^k . We can be confident that we can integrate along such curves, and that the Cauchy theory is valid for such curves. They are part of our toolkit in basic complex analysis.

¹For convenience, we have provided this simple proof of Morera's theorem only when the function is continuously differentiable. But it is of definite interest—and useful later—to know that Morera's theorem is true for functions that are only continuous.

Figure 3.2: A piecewise C^k curve.

Cauchy Integral Theorem: Let $f : U \rightarrow \mathbb{C}$ be holomorphic with $U \subseteq \mathbb{C}$ an open set. Then

$$\oint_{\gamma} f(z) dz = 0 \quad (3.5)$$

for each piecewise C^1 closed curve γ in U that can be deformed in U through closed curves to a point in U —see Figure 3.3. We call such a curve *homotopic to 0*. From the topological point of view, such a curve is trivial.

EXAMPLE 33 Let U be the region consisting of the disc $\{z \in \mathbb{C} : |z| < 2\}$ with the closed disc $\{z \in \mathbb{C} : |z - i| < 1/3\}$ removed. Let $\gamma : [0, 1] \rightarrow U$ be the curve $\gamma(t) = \cos t + [i/4] \sin t$. See Figure 3.4. If f is any holomorphic function on U then

$$\oint_{\gamma} f(z) dz = 0.$$

Perhaps more interesting is the following fact. Let P, Q be points of U . Let $\gamma : [0, 1] \rightarrow U$ be a curve that begins at P and ends at Q . Let $\mu : [0, 1] \rightarrow U$ be some other curve that begins at P and ends at Q . The requirement that we impose on these curves is that they do not surround any holes in U —in other words, the curve formed with γ followed by (the

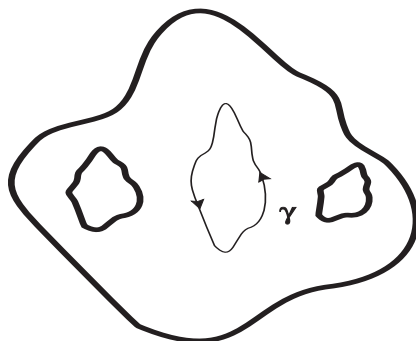


Figure 3.3: A curve γ on which the Cauchy integral theorem is valid.

reverse of) μ is homotopic to 0. Refer to Figure 3.5. If f is any holomorphic function on U then

$$\oint_{\gamma} f(z) dz = \oint_{\mu} f(z) dz .$$

The reason is that the curve τ that consists of γ followed by the reverse of μ is a closed curve in U . It is homotopic to 0. Thus the Cauchy integral theorem applies and

$$\oint_{\tau} f(z) dz = 0 .$$

Writing this out gives

$$\oint_{\gamma} f(z) dz - \oint_{\mu} f(z) dz = 0 .$$

That is our claim. □

3.1.3 Deformability of Curves

A central fact about the complex line integral is the deformability of curves. Let $\gamma : [a, b] \rightarrow U$ be a closed, piecewise C^1 curve in a region U of the complex plane. Let f be a holomorphic function on U . The value of the complex line integral

$$\oint_{\gamma} f(z) dz \tag{3.6}$$

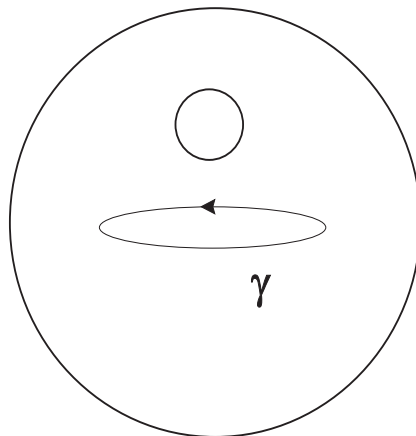


Figure 3.4: A curve γ on which the generalized Cauchy integral theorem is valid.

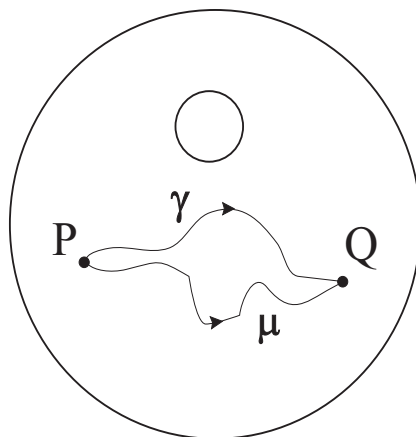


Figure 3.5: Two curves with equal complex line integrals.

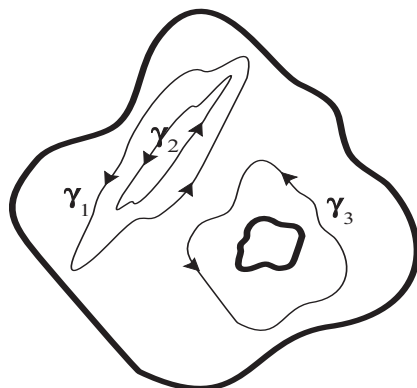


Figure 3.6: Deformation of curves.

does not change if the curve γ is smoothly deformed within the region U . Note that, in order for this statement to be valid, the curve γ must remain inside the region of holomorphicity U of f while it is being deformed, and it must remain a closed curve while it is being deformed. Figure 3.6 shows curves γ_1, γ_2 that *can* be deformed to one another, and a curve γ_3 that can be deformed to neither of the first two (because of the hole inside γ_3).

The reasoning behind the deformability principle is simplicity itself. Examine Figure 3.7. It shows a solid curve γ and a dashed curve $\tilde{\gamma}$. The latter should be thought of as a deformation of the former. Now let us examine the *difference* of the integrals over the two curves—see Figure 3.8. We see that this difference is in fact the integral of the holomorphic function f over a closed curve that *can be continuously deformed to a point*. Of course, by the Cauchy integral theorem, that integral is equal to 0. Thus the difference of the integral over γ and the integral over $\tilde{\gamma}$ is 0. That is the deformability principle.

A topological notion that is special to complex analysis is simple connectivity. We say that a domain $U \subseteq \mathbb{C}$ is *simply connected* if any closed curve in U can be continuously deformed to a point. See Figure 3.9. Simple connectivity is a mathematically rigorous condition that corresponds to the intuitive notion that the region U has no holes. Figure 3.10 shows a domain that is *not* simply connected. If U is simply connected, and γ is a closed curve in U , then it follows that γ can be continuously deformed to lie inside a disc in U . It follows that Cauchy's theorem applies to γ . To summarize:

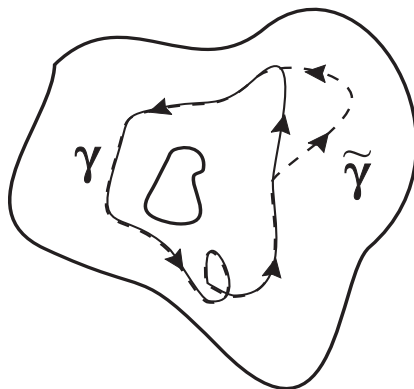


Figure 3.7: Deformation of curves.

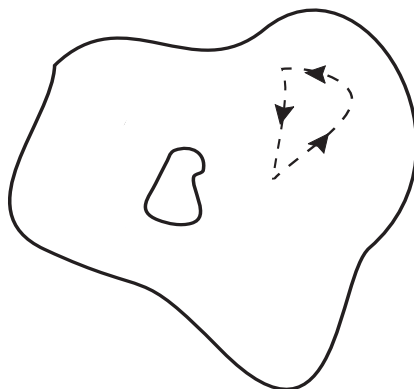


Figure 3.8: The difference of the integrals.

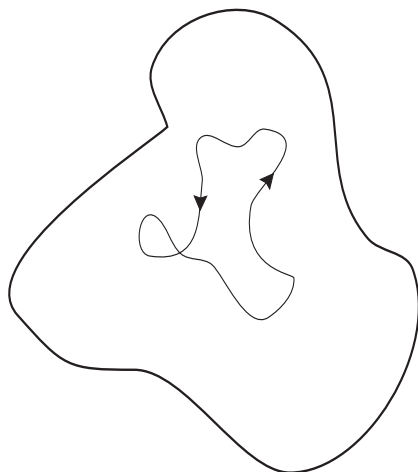


Figure 3.9: A simply connected domain.

on a simply connected region, Cauchy's theorem applies (without any further hypotheses) to any closed curve in U . Likewise, on a simply connected region U , Cauchy's integral formula (to be developed below) applies to any simple, closed curve that is oriented counterclockwise and to any point z that is inside that curve.

3.1.4 Cauchy Integral Formula, Basic Form

The Cauchy integral formula is derived from the Cauchy integral theorem. It tells us that we can express the value of a holomorphic function f in terms of a sort of average of its values around the boundary. This assertion is really quite profound; it turns out that the formula is key to many of the most important properties of holomorphic functions. We begin with a simple enunciation of Cauchy's idea.

Let $U \subseteq \mathbb{C}$ be a domain and suppose that $\overline{D}(P, r) \subseteq U$. Let $\gamma : [0, 1] \rightarrow \mathbb{C}$ be the C^1 parametrization $\gamma(t) = P + r \cos(2\pi t) + ir \sin(2\pi t)$. Then, for each $z \in D(P, r)$,

$$f(z) = \frac{1}{2\pi i} \oint_{\gamma} \frac{f(\zeta)}{\zeta - z} d\zeta. \quad (3.7)$$

Before we indicate the proof, we impose some simplifications. First, we may as well translate coordinates and assume that $P = 0$. Thus the Cauchy

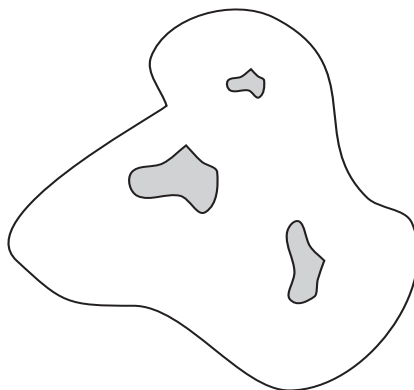


Figure 3.10: A domain that is *not* simply connected.

formula becomes

$$f(z) = \frac{1}{2\pi i} \oint_{\partial D(0,r)} \frac{f(\zeta)}{\zeta - z} d\zeta.$$

Our strategy is to apply the Cauchy integral *theorem* to the function

$$g(\zeta) = \frac{f(\zeta) - f(z)}{\zeta - z}.$$

In fact it can be checked—using Morera’s theorem for example—that g is still holomorphic.² Thus we may apply Cauchy’s theorem to see that

$$\oint_{\partial D(0,r)} g(\zeta) d\zeta = 0$$

or

$$\oint_{\partial D(0,r)} \frac{f(\zeta) - f(z)}{\zeta - z} d\zeta = 0.$$

But this just says that

$$\frac{1}{2\pi i} \oint_{\partial D(0,r)} \frac{f(z)}{\zeta - z} d\zeta = \frac{1}{2\pi i} \oint_{\partial D(0,r)} \frac{f(\zeta)}{\zeta - z} d\zeta. \quad (3.8)$$

²First, $\lim_{\zeta \rightarrow z} g(\zeta)$ exists because f is holomorphic. So g extends to be a continuous function on $D(0, r)$. We know that the integral of g over any curve that *does not* surround z must be zero—by the Cauchy integral theorem. And the integral over a curve that *does* pass through or surround z will therefore also be zero by a simple limiting argument.

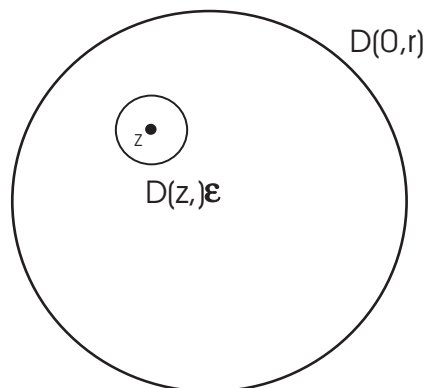


Figure 3.11: The deformation principle.

It remains to examine the left-hand side.

Now

$$\frac{1}{2\pi i} \oint_{\partial D(0,r)} \frac{f(z)}{\zeta - z} d\zeta = \frac{f(z)}{2\pi i} \oint_{\partial D(0,r)} \frac{1}{\zeta - z} d\zeta \quad (3.9)$$

and we must evaluate the integral. It is convenient to use deformation of curves to move the boundary $\partial D(0, r)$ to $\partial D(z, \epsilon)$, where $\epsilon > 0$ is chosen so small that $D(z, \epsilon) \subseteq D(0, r)$. See Figure 3.11. Then we have

$$\oint_{\partial D(0,r)} \frac{1}{\zeta - z} d\zeta = \oint_{\partial D(z,\epsilon)} \frac{1}{\zeta - z} d\zeta = \oint_{\partial D(0,\epsilon)} \frac{1}{\zeta} d\zeta. \quad (3.10)$$

In the last equality we used a simple change of variable.

Introducing the parametrization $t \mapsto \epsilon e^{it}$, $0 \leq t \leq 2\pi$, for the curve, we find that our integral is

$$\int_0^{2\pi} \frac{1}{e^{it}} i e^{it} dt = \int_0^{2\pi} i dt = 2\pi i.$$

Putting this information together with (3.8) and (3.9), we find that

$$f(z) = \frac{1}{2\pi i} \oint_{\partial D(0,r)} \frac{f(\zeta)}{\zeta - z} d\zeta.$$

That is the Cauchy integral formula when the domain is a disc.

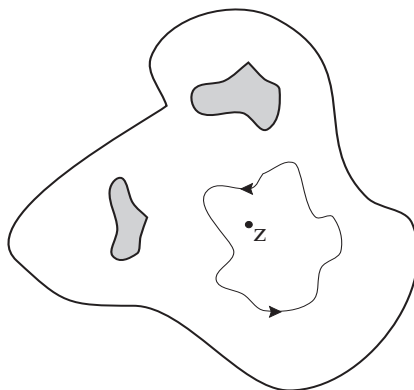


Figure 3.12: A curve that *can* be deformed to a point.

We shall see in Section 4.1.1 that the Cauchy integral formula gives an easy proof that a holomorphic function is infinitely differentiable. Thus the Cauchy-Goursat theorem is swept under the rug: holomorphic functions are as smooth as can be, and we can differentiate them at will.

3.1.5 More General Versions of the Cauchy Formula

A more general version of the Cauchy formula—the one that is typically used in practice—is this:

THEOREM 1 *Let $U \subseteq \mathbb{C}$ be a domain. Let $\gamma : [0, 1] \rightarrow U$ be a simple, closed curve that can be continuously deformed to a point inside U . See Figure 3.12. If f is holomorphic on U and z lies in the region interior to γ , then*

$$f(z) = \frac{1}{2\pi i} \oint_{\gamma} \frac{f(\zeta)}{\zeta - z} d\zeta.$$

The proof is nearly identical to the one that we have presented above in the special case. We omit the details.

EXAMPLE 34 Let $U = \{z = x + iy \in \mathbb{C} : -2 < x < 2, 0 < y < 3\} \setminus \overline{D}(-1 + (7/4)i, 1/10)$. Let $\gamma(t) = \cos t + i(3/2 + \sin t)$. Then the curve γ lies in U . The curve γ can certainly be deformed to a point inside U . Thus if f is any

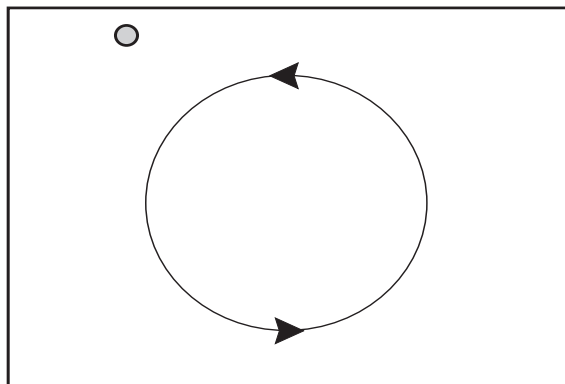


Figure 3.13: Illustration of the Cauchy integral formula.

holomorphic function on U then, for z inside the curve (see Figure 3.13),

$$f(z) = \frac{1}{2\pi i} \oint_{\gamma} \frac{f(\zeta)}{\zeta - z} d\zeta.$$

□

Exercises

1. Let $f(z) = z^2 - z$ and $\gamma(t) = (\cos t, \sin t)$, $0 \leq t \leq 2\pi$. Confirm the statement of the Cauchy integral theorem for this f and this γ by actually calculating the appropriate complex line integral.
2. The points $\pm \frac{1}{\sqrt{2}} \pm i \frac{1}{\sqrt{2}}$ lie on the unit circle. Let $\eta(t)$ be the counterclockwise-oriented, square path for which they are the vertices. Verify the conclusion of the Cauchy integral theorem for *this* path and the function $f(z) = z^2 - z$. Compare with Exercise 1.
3. The Cauchy integral theorem fails for the function $f(z) = \cot z$ on the annulus $\{z \in \mathbb{C} : 1 < |z| < 2\}$. Calculate the relevant complex line integral and verify that the value of the integral is *not* zero. What hypothesis of the Cauchy integral theorem is lacking?

4. Let u be a harmonic function in a neighborhood of the closed unit disc

$$\overline{D}(0, 1) = \{z \in \mathbb{C} : |z| \leq 1\}.$$

For each $P = (p_1, p_2) \in \partial D(0, 1)$, let $\nu(P) = \langle p_1, p_2 \rangle$ be the unit outward normal vector. Use Green's theorem to prove that

$$\int_{\partial D(0,1)} \frac{\partial}{\partial \nu} u(z) ds(z) = 0.$$

[**Hint:** Be sure to note that this is *not* a complex line integral. It is instead a standard calculus integral with respect to arc length.]

5. It is a fact (Morera's theorem) that if f is a continuously differentiable function on a domain Ω and if $\oint_{\gamma} f(z) dz = 0$ for every continuously differentiable, closed curve in Ω , then f is holomorphic on Ω . Restrict attention to curves that bound closed discs that lie in Ω . Apply Green's theorem to the hypothesis that we have formulated. Conclude that the two-dimensional integral of $\partial f / \partial \bar{z}$ is 0 on any disc in Ω . What does this tell you about $\partial f / \partial \bar{z}$?
6. Let f be holomorphic on a domain Ω and let P, Q be points of Ω . Let γ_1 and γ_2 be continuously differentiable curves in Ω that each begin at P and end at Q . What conditions on γ_1 , γ_2 , and Ω will guarantee that $\int_{\gamma_1} f(z) dz = \int_{\gamma_2} f(z) dz$?
7. Let Ω be a domain and suppose that γ is a simple, closed curve in Ω that is continuously differentiable. Suppose that $\oint_{\gamma} f(z) dz = 0$ for every holomorphic function f on Ω . What can you conclude about the domain Ω and the curve γ ?
8. Let D be the unit disc and suppose that $\gamma : [0, 1] \rightarrow D$ is a curve that circles the origin *twice* in the counterclockwise direction. Let f be holomorphic on D . What can you say about the value of

$$\oint_{\gamma} \frac{f(\zeta)}{\zeta - 0} d\zeta?$$

9. Suppose that the curve in the last exercise circles the origin twice in the clockwise direction. Then what can you say about the value of the integral

$$\oint_{\gamma} \frac{f(\zeta)}{\zeta - 0} d\zeta?$$

10. Let the domain D be the unit disc and let g be a *conjugate holomorphic function* on D (that is, \bar{g} is holomorphic). Then there exists a simple, closed, continuously differentiable curve γ in D such that $\oint_{\gamma} g(\zeta) d\zeta \neq 0$. Prove this assertion.
11. Let $U = \{z \in \mathbb{C} : 1 < |z| < 4\}$. Let $\gamma(t) = 3 \cos t + 3i \sin t$. Let $f(z) = 1/z$. Let $P = 2 + i0$. Verify with a direct calculation that

$$f(P) \neq \frac{1}{2\pi i} \oint_{\gamma} \frac{f(\zeta)}{\zeta - P} d\zeta.$$

12. In the preceding exercise, replace f with $g(\zeta) = \zeta^2$. Now verify that

$$g(P) = \frac{1}{2\pi i} \oint_{\gamma} \frac{g(\zeta)}{\zeta - P} d\zeta.$$

Explain why the answer to this exercise is different from the answer to the earlier exercise.

13. Let $U = D(0, 2)$ and let $\gamma(t) = \cos t + i \sin t$. Verify by a direct calculation that, for any $z \in D(0, 1)$,

$$1 = \frac{1}{2\pi i} \oint_{\gamma} \frac{1}{\zeta - z} d\zeta.$$

Now derive the same identity immediately using the Cauchy integral formula with the function $f(z) \equiv 1$.

14. Let $U = \{z \in \mathbb{C} : -4 < x < 4, -4 < y < 4\}$. Let $\gamma(t) = \cos t + i \sin t$. Let $\mu(t) = 2 \cos t + 3 \sin t$. Finally set $f(z) = z^2$. Of course each of the two curves lies in U . Draw a picture. Let $P = 1/2 + i/2$. Calculate

$$\frac{1}{2\pi i} \oint_{\gamma} \frac{f(\zeta)}{\zeta - P} d\zeta$$

and

$$\frac{1}{2\pi i} \oint_{\mu} \frac{f(\zeta)}{\zeta - P} d\zeta.$$

The answers that you obtain should be the same. Explain why.

15. Use the `MatLab` utility `cplxln.m` that you created in Exercise 13 of Section 1.5.7 to test the Cauchy integral theorem and formula in the following ways:

- (a) Let $f(z) = z^2$, $g(z) = \bar{z}$, and $h(z) = z \cdot \bar{z}$. Use `cplxln.m` to calculate the complex line integral of each of these functions along the curve $\gamma(t) = e^{it}$, $0 \leq t \leq 2\pi$. How do you account for the answers that you obtain?
- (b) Let $k(z) = \bar{z}^2$ and $m(z) = 1/z^2$. Use the curve γ from part (a). Clearly neither of these functions is holomorphic on $\overline{D}(0, 1)$. Nonetheless, you can use the utility `cplxln.m` to calculate that $\oint_{\gamma} k(z) dz = 0$ and $\oint_{\gamma} m(z) dz = 0$. How can you account for this?
- (c) Let γ be as in part (a). Calculate, using the `MatLab` utility `cplxln.m`, the integrals

- $\oint_{\gamma} \frac{1}{z} dz$,
- $\oint_{\gamma} \frac{1}{z - 1/2} dz$,
- $\oint_{\gamma} \frac{1}{z - (1/3 + i/4)} dz$,
- $\oint_{\gamma} \frac{1}{z - 0.999999} dz$.

You should obtain the same answer in all four cases. Explain why.

- (d) Let $p(z) = e^z$. Let the curve γ be as in part (a). Use the `MatLab` utility `cplxln.m` to calculate

- $\frac{1}{2\pi i} \oint_{\gamma} \frac{p(z)}{z} dz$,
- $\frac{1}{2\pi i} \oint_{\gamma} \frac{p(z)}{z - 1/2} dz$,
- $\frac{1}{2\pi i} \oint_{\gamma} \frac{p(z)}{z - (1/3 + i/4)} dz$.

The answers you get should be, respectively, $p(0)$, $p(1/2)$, and $p(1/3 + i/4)$. Verify this assertion.

3.2 Variants of the Cauchy Formula

The Cauchy formula is a remarkably flexible tool that can be applied even when the domain U in question is *not* simply connected. Rather than attempting to formulate a general result, we illustrate the ideas here with some examples.

EXAMPLE 35 Let $U = \{z \in \mathbb{C} : 1 < |z| < 4\}$. Let $\gamma_1(t) = 2 \cos t + 2i \sin t$ and $\gamma_2(t) = 3 \cos t + 3i \sin t$. See Figure 3.14. If f is any holomorphic function on U and if the point z satisfies $2 < |z| < 3$ (again, see Figure 3.14) then

$$f(z) = \frac{1}{2\pi i} \oint_{\gamma_2} \frac{f(\zeta)}{\zeta - z} d\zeta - \frac{1}{2\pi i} \oint_{\gamma_1} \frac{f(\zeta)}{\zeta - z} d\zeta. \quad (3.11)$$

The beauty of this result is that it can be established with a simple diagram. Refer to Figure 3.15. We see that integration over γ_2 and $-\gamma_1$, as indicated in formula (3.11), is just the same as integrating over a single contour γ^* . And, with a slight deformation, we see that that contour is equivalent—for the purposes of integration—with integration over a contour $\tilde{\gamma}^*$ that is homotopic to zero. Thus, with a bit of manipulation, we see that the integrations in (3.11) are equivalent to integration over a curve for which we know that the Cauchy formula holds.

That establishes formula (3.11). \square

EXAMPLE 36 Consider the region

$$U = D(0, 6) \setminus [\overline{D}(-3 + 0i, 2) \cup \overline{D}(3 + 0i, 2)].$$

It is depicted in Figure 3.16. We also show in the figure *three* contours of integration: $\gamma_1, \gamma_2, \gamma_3$. We deliberately do not give formulas for these curves, because we want to stress that the reasoning here is geometric and does *not* depend on formulas.

Now suppose that f is a holomorphic function on U . We want to write a Cauchy integral formula—for the function f and the point z —that will be valid in this situation. It turns out that the correct formula is

$$f(z) = \frac{1}{2\pi i} \oint_{\gamma_1} \frac{f(\zeta)}{\zeta - z} d\zeta - \frac{1}{2\pi i} \oint_{\gamma_2} \frac{f(\zeta)}{\zeta - z} d\zeta - \frac{1}{2\pi i} \oint_{\gamma_3} \frac{f(\zeta)}{\zeta - z} d\zeta.$$

The justification, parallel to that in the last example, is shown in Figure 3.17.

\square

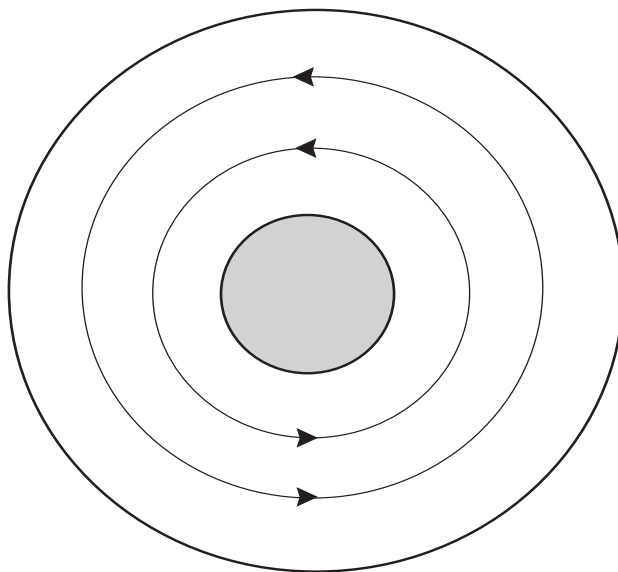


Figure 3.14: A variant of the Cauchy integral formula.

3.3 A Coda on the Limitations of the Cauchy Integral Formula

If f is any continuous function on the boundary of the unit disc $D = D(0, 1)$, then the Cauchy integral

$$F(z) \equiv \frac{1}{2\pi i} \oint_{\partial D} \frac{f(\zeta)}{\zeta - z} d\zeta \quad (3.12)$$

defines a holomorphic function $F(z)$ on D (use Morera's theorem, for example, to confirm this assertion). What does the new function F have to do with the original function f ? In general, not much.

For example, if $f(\zeta) = \bar{\zeta}$, then $F(z) \equiv 0$ (exercise). In no sense is the original function f any kind of “boundary limit” of the new function F . The question of which functions f are “natural boundary functions” for holomorphic functions F (in the sense that F is a continuous extension of f to the closed disc) is rather subtle. Its answer is well understood, but is best formulated in terms of Fourier series and the so-called Hilbert transform. The complete story is given in [KRA1].

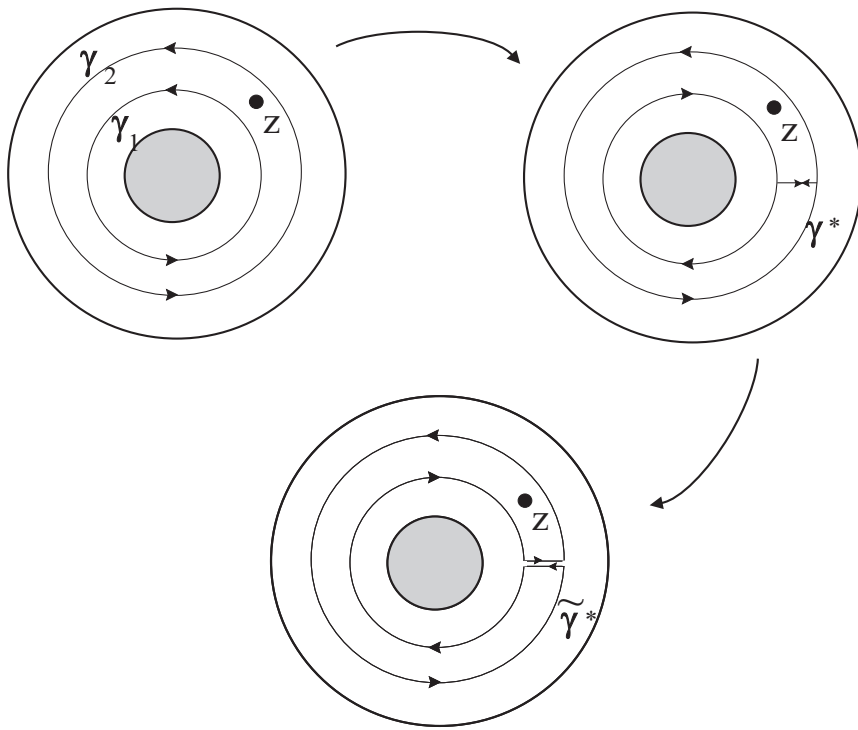


Figure 3.15: Turning two contours into one.

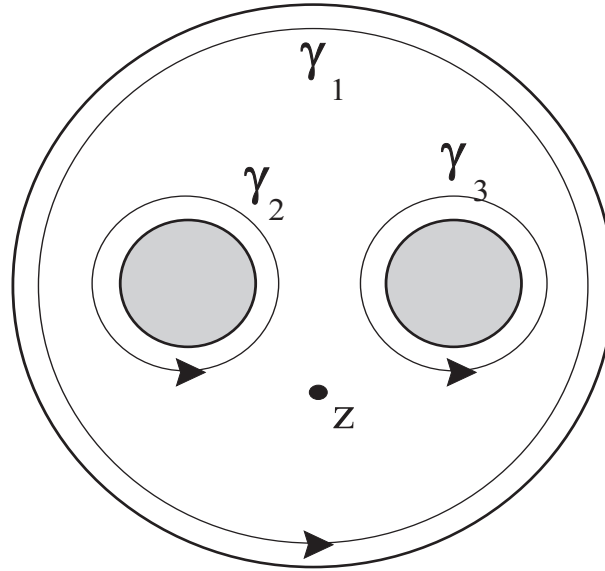


Figure 3.16: A triply connected domain.

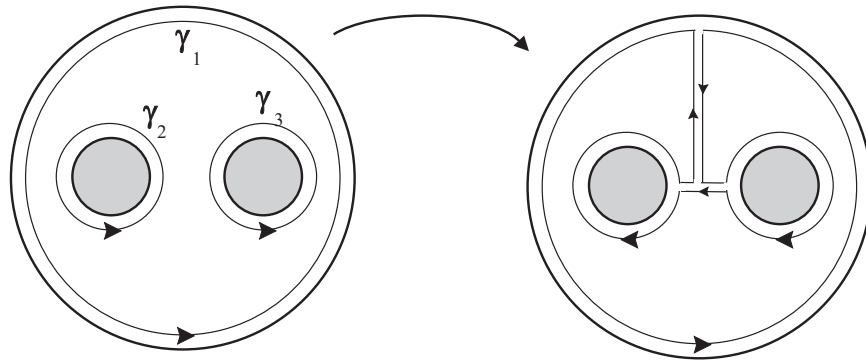


Figure 3.17: Turning three contours into one.

Contrast this situation for holomorphic functions with the much more succinct and clean situation for harmonic functions (Section 9.3).

Exercises

1. Let

$$\varphi(e^{i\theta}) = \begin{cases} 1 & \text{if } 0 \leq \theta \leq \pi \\ -1 & \text{if } \pi < \theta \leq 2\pi. \end{cases}$$

Let $\gamma(t) = e^{it}$, $0 \leq t \leq 2\pi$. Use the `MatLab` utility `cplxln.m` to calculate

$$\Phi(a) = \oint_{\gamma} \frac{\varphi(z)}{z-a} dz,$$

for $a = 0, 1/2, i/3$. Calculate the value of the integral for **(i)** a sequence of a 's tending to 1, **(ii)** a sequence of a 's tending to i , and **(iii)** a sequence of a 's tending to $1/\sqrt{2} + i/\sqrt{2}$. What can you conclude about the relationship (if any) between the values of the function Φ in the interior of the disc with the values of the function φ on the boundary of the disc?

2. Repeat the first exercise with the function φ replaced by

$$\psi(z) = \bar{z}.$$

3. Repeat the first exercise with the function φ replaced by

$$\eta(z) = \frac{1}{z}.$$

4. Repeat the first exercise with the function φ replaced by

$$\mu(z) = \frac{1}{z^2}.$$

5. Use the `MatLab` utility `cplxln.m` to calculate the Cauchy integral $\frac{1}{2\pi i} \oint_{\partial D} \frac{f(\zeta)}{\zeta-z} d\zeta$ for these functions f on the boundary ∂D of the unit disc D :

(a) $f(\zeta) = \frac{1}{\zeta^2}$

- (b) $f(\zeta) = \zeta^2$
- (c) $f(\zeta) = \zeta \cdot \bar{\zeta}$
- (d) $f(\zeta) = \frac{\zeta}{3+\zeta}$
- (e) $f(\zeta) = \frac{\zeta}{\bar{\zeta}}$
- (f) $f(\zeta) = \frac{\bar{\zeta}^2}{\zeta}$

In each instance, comment on the relationship between the holomorphic function you have created on the interior D of the disc and the original function f on the boundary of the disc.

6. Let f be a continuous, complex-valued function on the boundary of the unit disc D . Let F be its Cauchy integral. Interpret f as a force field. In the case when F agrees with f at the boundary, what does this say about the force field? In the case when F *does not* agree with f at the boundary, what does *that* say about the force field?

Chapter 4

Applications of the Cauchy Theory

4.1 The Derivatives of a Holomorphic Function

One of the remarkable features of holomorphic function theory is that we can express the derivative of a holomorphic function in terms of the function itself. Nothing of the sort is true for real functions. One upshot is that we can obtain powerful estimates for the derivatives of holomorphic functions.

We shall explore this phenomenon in the present section.

EXAMPLE 37 On the real line \mathbb{R} , let

$$f_k(x) = \sin(kx).$$

Then of course $|f_k(x)| \leq 1$ for all k and all x . Yet $f'_k(x) = k \cos(kx)$ and $|f'_k(0)| = k$. So there is no sense, and no hope, of bounding the derivative of a function by means of the function itself. We will find matters to be quite different for holomorphic functions. \square

4.1.1 A Formula for the Derivative

Let $U \subseteq \mathbb{C}$ be an open set and let f be holomorphic on U . Then $f \in C^\infty(U)$. Moreover, if $\overline{D}(P, r) \subseteq U$ and $z \in D(P, r)$, then

$$\left(\frac{d}{dz}\right)^k f(z) = \frac{k!}{2\pi i} \oint_{|\zeta-P|=r} \frac{f(\zeta)}{(\zeta-z)^{k+1}} d\zeta, \quad k = 0, 1, 2, \dots \quad (4.1)$$

The proof of this new formula is direct. For consider the Cauchy formula:

$$f(z) = \frac{1}{2\pi i} \oint_{\partial D(0,r)} \frac{f(\zeta)}{\zeta-z} d\zeta.$$

We may differentiate both sides of this equation:

$$\frac{d}{dz} f(z) = \frac{d}{dz} \left[\frac{1}{2\pi i} \oint_{\partial D(0,r)} \frac{f(\zeta)}{\zeta-z} d\zeta \right].$$

Now we wish to justify passing the derivative on the right under the integral sign. A justification from first principles may be obtained by examining the Newton quotients for the derivative. Alternatively, one can cite a suitable limit theorem as in [RUD1] or [KRA2]. In any event, we obtain

$$\begin{aligned} \frac{d}{dz} f(z) &= \frac{1}{2\pi i} \oint_{\partial D(0,r)} \frac{d}{dz} \left[\frac{f(\zeta)}{\zeta-z} \right] d\zeta \\ &= \frac{1}{2\pi i} \oint_{\partial D(0,r)} f(\zeta) \cdot \frac{d}{dz} \left[\frac{1}{\zeta-z} \right] d\zeta \\ &= \frac{1}{2\pi i} \oint_{\partial D(0,r)} f(\zeta) \cdot \frac{1}{(\zeta-z)^2} d\zeta. \end{aligned}$$

This is in fact the special instance of formula (4.1) when $k = 1$. The cases of higher k are obtained through additional differentiations, or by induction.

4.1.2 The Cauchy Estimates

If f is a holomorphic on a region containing the closed disc $\overline{D}(P, r)$ and if $|f| \leq M$ on $\overline{D}(P, r)$, then

$$\left| \frac{\partial^k}{\partial z^k} f(P) \right| \leq \frac{M \cdot k!}{r^k}. \quad (4.2)$$

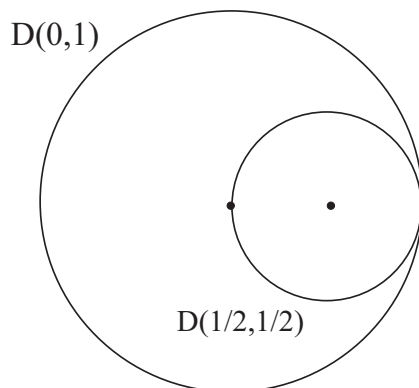


Figure 4.1: The Cauchy estimates.

In fact this formula is a result of direct estimation from (4.1). For we have

$$\left| \frac{\partial^k}{\partial z^k} f(P) \right| = \left| \frac{k!}{2\pi i} \oint_{|\zeta - P| = r} \frac{f(\zeta)}{(\zeta - z)^{k+1}} d\zeta \right| \leq \frac{k!}{2\pi} \cdot \frac{M}{r^{k+1}} \cdot 2\pi r = \frac{Mk!}{r^k}.$$

EXAMPLE 38 Let $f(z) = (z^3 + 1)e^{z^2}$ on the unit disc $D(0, 1)$. Obviously

$$|f(z)| \leq 2 \cdot |e^{z^2}| = e^{x^2 - y^2} \leq e \quad \text{for all } z \in D(0, 1).$$

We may then conclude, by the Cauchy estimates applied to f on $D(1/2, 1/2) \subseteq D(0, 1)$ (see Figure 4.1), that

$$|f'(1/2)| \leq \frac{e \cdot 1!}{1/2} = 2e$$

and

$$|f''(1/2)| \leq \frac{e \cdot 2!}{(1/2)^2} = 8e.$$

Of course one may perform the tedious calculation of these derivatives and determine that $f'(1/2) \approx 1.1235$ and $f''(1/2) \approx 6.2596$. But Cauchy's estimates allow us to estimate the derivatives by way of soft analysis. \square

4.1.3 Entire Functions and Liouville's Theorem

A function f is said to be *entire* if it is defined and holomorphic on all of \mathbb{C} , that is, $f : \mathbb{C} \rightarrow \mathbb{C}$ is holomorphic. For instance, any holomorphic polynomial is entire, e^z is entire, and $\sin z, \cos z$ are entire. The function $f(z) = 1/z$ is not entire because it is undefined at $z = 0$. [In a sense that we shall make precise later (Section 5.1), this last function has a “singularity” at 0.] The question we wish to consider is: “Which entire functions are bounded?” This question has a very elegant and complete answer as follows:

THEOREM 2 (Liouville's Theorem) *A bounded entire function is constant.*

Proof: Let f be entire and assume that $|f(z)| \leq M$ for all $z \in \mathbb{C}$. Fix a $P \in \mathbb{C}$ and let $r > 0$. We apply the Cauchy estimate (4.2) for $k = 1$ on $\overline{D}(P, r)$. So

$$\left| \frac{\partial}{\partial z} f(P) \right| \leq \frac{M \cdot 1!}{r}. \quad (4.3)$$

Since this inequality is true for every $r > 0$, we conclude (by letting $r \rightarrow \infty$) that

$$\frac{\partial f}{\partial z}(P) = 0. \quad (4.4)$$

Since P was arbitrary, we conclude that

$$\frac{\partial f}{\partial z} \equiv 0. \quad (4.5)$$

Of course we also know, since f is holomorphic, that

$$\frac{\partial f}{\partial \bar{z}} \equiv 0. \quad (4.6)$$

It follows from linear algebra then that

$$\frac{\partial f}{\partial x} \equiv 0 \quad \text{and} \quad \frac{\partial f}{\partial y} \equiv 0. \quad (4.7)$$

Therefore f is constant. □

The reasoning that establishes Liouville's theorem can also be used to prove this more general fact: If $f : \mathbb{C} \rightarrow \mathbb{C}$ is an entire function and if for some real number C and some positive integer k , it holds that

$$|f(z)| \leq C \cdot (1 + |z|)^k \quad (4.8)$$

for all z , then f is a polynomial in z of degree at most k . We leave the details for the interested reader.

4.1.4 The Fundamental Theorem of Algebra

One of the most elegant applications of Liouville's Theorem is a proof of what is known as the Fundamental Theorem of Algebra (see also Sections 1.2.4 and 6.3.3):

The Fundamental Theorem of Algebra: Let $p(z)$ be a non-constant (holomorphic) polynomial in z . Then p has a root. That is, there exists an $\alpha \in \mathbb{C}$ such that $p(\alpha) = 0$.

Proof: Suppose not. Then $g(z) = 1/p(z)$ is entire. Also, when $|z| \rightarrow \infty$, then $|p(z)| \rightarrow +\infty$. Thus $1/|p(z)| \rightarrow 0$ as $|z| \rightarrow \infty$; hence g is bounded. By Liouville's Theorem, g is constant, hence p is constant. Contradiction. \square

If, in the theorem, p has degree $k \geq 1$, then let α_1 denote the root provided by the Fundamental Theorem. By the Euclidean algorithm (see [HUN]), we may divide $z - \alpha_1$ into p to obtain

$$p(z) = (z - \alpha_1) \cdot p_1(z) + r_1(z). \quad (4.9)$$

Here p_1 is a polynomial of degree $k - 1$ and r_1 is the remainder term of degree 0 (that is, less than 1). Substituting α_1 into this last equation gives $0 = 0 + r_1$, hence we see that $r_1 = 0$. Thus the Euclidean algorithm has taught us that

$$p(z) = (z - \alpha_1) \cdot p_1(z).$$

If $k - 1 \geq 1$, then, reasoning as above with the Fundamental Theorem, p_1 has a root α_2 . Thus p_1 is divisible by $(z - \alpha_2)$ and we have

$$p(z) = (z - \alpha_1) \cdot (z - \alpha_2) \cdot p_2(z) \quad (4.10)$$

for some polynomial $p_2(z)$ of degree $k - 2$. This process can be continued until we arrive at a polynomial p_k of degree 0; that is, p_k is constant. We have derived the following fact: If $p(z)$ is a holomorphic polynomial of degree k , then there are k complex numbers $\alpha_1, \dots, \alpha_k$ (not necessarily distinct) and a nonzero constant C such that

$$p(z) = C \cdot (z - \alpha_1) \cdots (z - \alpha_k). \quad (4.11)$$

If some of the roots of p coincide, then we say that p has *multiple roots*. To be specific, if m of the values $\alpha_{n_1}, \dots, \alpha_{n_m}$ are equal to some complex number α , then we say that p has a root of order m at α (or that p has a root α of *multiplicity* m). An example will make the idea clear: Let

$$p(z) = (z - 5)^3 \cdot (z + 2)^8 \cdot (z - 7) \cdot (z + 6). \quad (4.12)$$

Thus p is a polynomial of degree 13. We say that p has a root of order 3 at 5, a root of order 8 at -2 , and it has roots of order 1 at 7 and at -6 . We also say that p has *simple roots* at 7 and -6 .

4.1.5 Sequences of Holomorphic Functions and Their Derivatives

A sequence of functions g_j defined on a common domain E is said to *converge uniformly* to a limit function g if, for each $\epsilon > 0$, there is a number $N > 0$ such that, for all $j > N$, it holds that $|g_j(x) - g(x)| < \epsilon$ for every $x \in E$. The key point is that the degree of closeness of $g_j(x)$ to $g(x)$ is independent of $x \in E$.

Let $f_j : U \rightarrow \mathbb{C}$, $n = 1, 2, 3, \dots$, be a sequence of holomorphic functions on a region U in \mathbb{C} . Suppose that there is a function $f : U \rightarrow \mathbb{C}$ such that, for each compact subset E (a compact set is one that is closed and bounded—see Figure 4.2) of U , the restricted sequence $f_j|_E$ converges uniformly to $f|_E$. Then f is holomorphic on U . [In particular, $f \in C^\infty(U)$.]

One may see this last assertion by examining the Cauchy integral formula:

$$f_j(z) = \frac{1}{2\pi i} \oint \frac{f_j(\zeta)}{\zeta - z} d\zeta.$$

Now we may let $j \rightarrow \infty$, and invoke the uniform convergence to pass the limit under the integral sign on the right (see [KRA2] or [RUD1]). The result is

$$\begin{aligned} \lim_{j \rightarrow \infty} f_j(z) &= \lim_{j \rightarrow \infty} \frac{1}{2\pi i} \oint \frac{f_j(\zeta)}{\zeta - z} d\zeta \\ &= \frac{1}{2\pi i} \oint \lim_{j \rightarrow \infty} \frac{f_j(\zeta)}{\zeta - z} d\zeta \\ &= \frac{1}{2\pi i} \oint \frac{\lim_{j \rightarrow \infty} f_j(\zeta)}{\zeta - z} d\zeta \end{aligned}$$

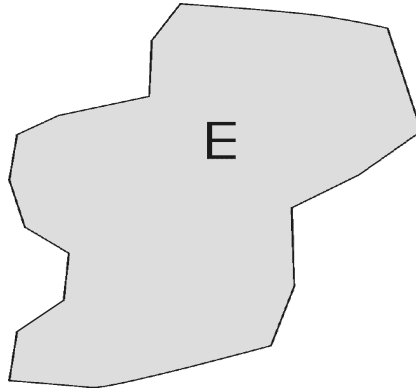


Figure 4.2: A compact set is closed and bounded.

or

$$f(z) = \frac{1}{2\pi i} \oint \frac{f(\zeta)}{\zeta - z} d\zeta.$$

The right-hand side is plainly a holomorphic function of z (simply differentiate under the integral sign, or apply Morera's theorem). Thus f is holomorphic.

If f_j, f, U are as in the preceding paragraph, then, for any $k \in \{0, 1, 2, \dots\}$, we have

$$\left(\frac{\partial}{\partial z}\right)^k f_j(z) \rightarrow \left(\frac{\partial}{\partial z}\right)^k f(z) \quad (4.13)$$

uniformly on compact sets. This again follows from an examination of the Cauchy integral formula (or from the Cauchy estimates). We omit the details.

4.1.6 The Power Series Representation of a Holomorphic Function

The ideas being considered in this section can be used to develop our understanding of power series. A *power series*

$$\sum_{n=0}^{\infty} a_n(z - P)^n \quad (4.14)$$

is defined to be the limit of its *partial sums*

$$S_N(z) = \sum_{n=0}^N a_n(z - P)^n. \quad (4.15)$$

We say that the partial sums *converge* to the sum of the entire series.

Any given power series has a *disc of convergence*. More precisely, let

$$r = \frac{1}{\limsup_{j \rightarrow \infty} |a_j|^{1/j}}. \quad (4.16)$$

The power series (4.15) will then certainly converge on the disc $D(P, r)$; the convergence will be absolute and uniform (by the root test) on any disc $\overline{D}(P, r')$ with $r' < r$.

For clarity, we should point out that in many examples the sequence $|a_j|^{1/j}$ actually converges as $j \rightarrow \infty$. Then we may take r to be equal to $1/\lim_{j \rightarrow \infty} |a_j|^{1/j}$. The reader should be aware, however, that in case the sequence $\{|a_j|^{1/j}\}$ does not converge, then one must use the more formal definition (4.16) of r . See [KRA2], [RUD1].

Of course the partial sums, being polynomials, are holomorphic on *any* disc $D(P, r)$. If the disc of convergence of the power series is $D(P, r)$, then let f denote the function to which the power series converges. Then, for any $0 < r' < r$, we have that

$$S_N(z) \rightarrow f(z), \quad (4.17)$$

uniformly on $\overline{D}(P, r')$. We can conclude immediately that $f(z)$ is holomorphic on $D(P, r)$. Moreover, we know that

$$\left(\frac{\partial}{\partial z}\right)^k S_N(z) \rightarrow \left(\frac{\partial}{\partial z}\right)^k f(z). \quad (4.18)$$

This shows that a differentiated power series has a disc of convergence at least as large as the disc of convergence (with the same center) of the original series, and that the differentiated power series converges on that disc to the derivative of the sum of the original series. In fact, the differentiated series has exactly the same radius of convergence as the original.

The most important fact about power series for complex function theory is this: If f is a holomorphic function on a domain $U \subseteq \mathbb{C}$, if $P \in U$, and if

the disc $D(P, r)$ lies in U , then f may be represented as a convergent power series on $D(P, r)$. Explicitly, we have

$$f(z) = \sum_{n=0}^{\infty} a_n(z - P)^n.$$

The reason that any holomorphic f has a power series expansion again relies on the Cauchy formula. If f is holomorphic on U and $\overline{D}(P, r) \subseteq U$, then we write, for $z \in D(P, r)$,

$$\begin{aligned} f(z) &= \frac{1}{2\pi i} \oint_{\partial D(P, r)} \frac{f(\zeta)}{\zeta - z} d\zeta \\ &= \frac{1}{2\pi i} \oint_{\partial D(P, r)} \frac{f(\zeta)}{\zeta - P} \cdot \frac{1}{1 - \frac{z-P}{\zeta-P}} d\zeta. \end{aligned} \tag{4.19}$$

Observe that $|(z - P)/(\zeta - P)| < 1$. So we may expand the second fraction in a power series:

$$\frac{1}{1 - \frac{z-P}{\zeta-P}} = \sum_{j=0}^{\infty} \left(\frac{z - P}{\zeta - P} \right)^j.$$

Substituting this information into (4.19) yields

$$\begin{aligned} &= \frac{1}{2\pi i} \oint_{\partial D(P, r)} \frac{f(\zeta)}{\zeta - P} \cdot \sum_{j=0}^{\infty} \left(\frac{z - P}{\zeta - P} \right)^j d\zeta \\ &= \sum_{j=0}^{\infty} (z - P)^j \cdot \left[\frac{1}{2\pi i} \oint_{\partial D(P, r)} \frac{f(\zeta)}{(\zeta - P)^{j+1}} d\zeta \right] \\ &= \sum_{j=0}^{\infty} (z - P)^j \cdot \frac{f^{(j)}(P)}{j!}. \end{aligned} \tag{4.20}$$

We have used here standard results about switching series and integrals, for which see [KRA2] or [RUD1].

The last formula gives us an explicit power series expansion for the holomorphic function f . It further reveals explicitly that the coefficient of $(z - P)^j$ (that is, the expression in brackets) is $f^{(j)}(P)/j!$.

Let us now examine the question of calculating the power series expansion from a slightly different point of view. If we suppose in advance that f has a convergent power series expansion on the disc $D(P, r)$, then we may write

$$f(z) = a_0 + a_1(z - P) + a_2(z - P)^2 + a_3(z - P)^3 + \dots \tag{4.21}$$

Now let us evaluate both sides at $z = P$. We see immediately that $f(P) = a_0$.

Next, differentiate both sides of (4.21). The result is

$$f'(z) = a_1 + 2a_2(z - P) + 3a_3(z - P)^2 + \cdots .$$

Again, evaluate both sides at $z = P$. The result is $f'(P) = a_1$.

We may differentiate one more time and evaluate at $z = P$ to learn that $f''(P) = 2a_2$. Continuing in this manner, we discover that $f^{(k)}(P) = k!a_k$, where the superscript (k) denotes k derivatives.

We have discovered a convenient and elegant formula for the power series coefficients:

$$a_k = \frac{f^{(k)}(P)}{k!}. \quad (4.22)$$

This is consistent with what we learned in (4.20).

EXAMPLE 39 Let us determine the power series for $f(z) = z \sin z$ expanded about the point $P = \pi$. We begin by calculating

$$\begin{aligned} f'(z) &= \sin z + z \cos z \\ f''(z) &= 2 \cos z - z \sin z \\ f'''(z) &= -3 \sin z - z \cos z \\ f^{(iv)}(z) &= -4 \cos z + z \sin z \end{aligned}$$

and, in general,

$$f^{(2\ell+1)}(z) = (-1)^\ell(2\ell + 1) \sin z + (-1)^\ell z \cos z$$

and

$$f^{(2\ell)}(z) = (-1)^{\ell+1}(2\ell) \cos z + (-1)^\ell z \sin z .$$

Evaluating at π , and using formula (4.22), we find that

$$\begin{aligned} a_0 &= 0 \\ a_1 &= -\pi \\ a_2 &= -1 \\ a_3 &= \frac{\pi}{3!} \\ a_4 &= \frac{1}{3!} \\ a_5 &= -\frac{\pi}{5!} \\ a_6 &= -\frac{1}{5!}, \end{aligned}$$

and, in general,

$$a_{2\ell} = \frac{(-1)^\ell}{(2\ell - 1)!}$$

and

$$a_{2\ell+1} = (-1)^{\ell+1} \frac{\pi}{2\ell + 1}.$$

In conclusion, the power series expansion for $f(z) = z \sin z$, expanded about the point $P = \pi$, is

$$\begin{aligned} f(z) &= -\pi(z - \pi) - (z - \pi)^2 + \frac{\pi}{3!} \cdot (z - \pi)^3 + \frac{1}{3!} \cdot (z - \pi)^4 \\ &\quad - \frac{\pi}{5!} \cdot (z - \pi)^5 - \frac{1}{5!} \cdot (z - \pi)^6 + \dots \\ &= \pi \sum_{\ell=0}^{\infty} (-1)^{\ell+1} \frac{(z - \pi)^{2\ell+1}}{(2\ell + 1)!} + \sum_{\ell=1}^{\infty} (-1)^\ell \frac{(z - \pi)^{2\ell}}{(2\ell - 1)!}. \end{aligned}$$

□

In summary, we have an explicit way of calculating the power series expansion of any holomorphic function f about a point P of its domain, and we have an *a priori* knowledge of the disc on which the power series representation will converge.

Sometimes one can derive a power series expansion by simple algebra and calculus tricks—thereby avoiding the tedious calculation of coefficients that we have just illustrated. An example will illustrate the technique:

EXAMPLE 40 Let us derive a power series expansion about 0 of the function

$$f(z) = \frac{z^2}{(1 - z^2)^2}.$$

It is a standard fact from calculus that

$$\frac{1}{1 - \alpha} = 1 + \alpha + \alpha^2 + \alpha^3 + \dots$$

for any $|\alpha| < 1$. Letting $\alpha = z^2$ yields

$$\frac{1}{1 - z^2} = 1 + z^2 + z^4 + z^6 + \dots.$$

Now a result from real analysis [KRA2] tells us that power series may be differentiated term by term. Thus

$$\frac{2z}{(1-z^2)^2} = 2z + 4z^3 + 6z^5 + \dots$$

Finally, multiplying both sides by $z/2$, we find that

$$\frac{z^2}{(1-z^2)^2} = 2z^2 + 4z^4 + 6z^6 + \dots = \sum_{j=1}^{\infty} 2j \cdot z^{2j}.$$

□

4.1.7 Table of Elementary Power Series

The table below presents a summary of elementary power series expansions.

Table of Elementary Power Series

Function	Power Series abt. 0	Disc of Convergence
$\frac{1}{1-z}$	$\sum_{n=0}^{\infty} z^n$	$\{z : z < 1\}$
$\frac{1}{(1-z)^2}$	$\sum_{n=1}^{\infty} n z^{n-1}$	$\{z : z < 1\}$
$\cos z$	$\sum_{n=0}^{\infty} (-1)^n \frac{z^{2n}}{(2n)!}$	all z
$\sin z$	$\sum_{n=0}^{\infty} (-1)^n \frac{z^{2n+1}}{(2n+1)!}$	all z
e^z	$\sum_{n=0}^{\infty} \frac{z^n}{n!}$	all z
$\log(z+1)$	$\sum_{n=0}^{\infty} \frac{(-1)^n}{n+1} z^{n+1}$	$\{z : z < 1\}$
$(z+1)^\beta$	$\sum_{n=0}^{\infty} \binom{\beta}{n} z^n$	$\{z : z < 1\}$

Exercises

1. Calculate the power series expansion about 0 of $f(z) = \sin z^3$. Now calculate the expansion about π .
2. Calculate the power series expansion about $\pi/2$ of $g(z) = \tan[z/2]$. Now calculate the expansion about 0.
3. Calculate the power series expansion about 2 of $h(z) = z/(z^2 - 1)$.
4. Suppose that f is an entire function, k is a positive integer, and

$$|f(z)| \leq C(1 + |z|^k)$$

for all $z \in \mathbb{C}$. Prove that f must be a polynomial of degree at most k .

5. Suppose that f is an entire function, p is a polynomial, and f/p is bounded. What can you conclude about f ?
6. Let $0 < m < k$ be integers. Give an example of a polynomial of degree k that has just m distinct roots.
7. Suppose that the polynomial p has a double root at the complex value z_0 . Prove that $p(z_0) = 0$ and $p'(z_0) = 0$.
8. Suppose that the polynomial p has a simple zero at z_0 and let γ be a simple closed, continuously differentiable curve that encircles z_0 (oriented in the counterclockwise direction). What can you say about the value of

$$\frac{1}{2\pi i} \oint_{\gamma} \frac{p'(\zeta)}{p(\zeta)} d\zeta ?$$

[**Hint:** Try this first with the polynomials $p(z) = z$, $p(z) = z^2$, and $p(z) = z^3$.]

9. Let $\Omega \subseteq \mathbb{C}$ be a domain and let $\{f_n\}$ be holomorphic functions on Ω . Assume that the sequence $\{f_n\}$ converges uniformly on Ω . Prove that, if K is any closed, bounded set in Ω and m is a positive integer, then the sequence $f_n^{(m)}$ will converge uniformly on K .
10. Prove a version of the Cauchy estimates for harmonic functions.

11. For each k, M, r , give an example to show that the Cauchy estimates are sharp. That is, Find a function for which the inequality is an equality.
12. Prove this sharpening of Liouville's theorem: *If f is an entire function and $|f(z)| \leq C|z|^{1/2} + D$ for all z and for some constants C, D then f is constant.* How much can you increase the exponent $1/2$ and still draw the same conclusion?
13. Suppose that $p(z)$ is a polynomial of degree k with leading coefficient 1. Assume that all the zeros of p lie in unit disc. Prove that, for z sufficiently large, $|p(z)| \geq 9|z|^k/10$.
14. Let f be a holomorphic function defined on some open region $U \subseteq \mathbb{C}$. Fix a point $P \in U$. Prove that the power series expansion of f about P will converge absolutely and uniformly on any disc $\overline{D}(P, r)$ with $r < \text{dist}(P, \partial U)$.
15. Let $0 \leq r \leq \infty$. Fix a point $P \in \mathbb{C}$. Give an example of a complex power series, centered at $P \in \mathbb{C}$, with radius of convergence precisely r .
16. We know from the elementary theory of geometric series that

$$\frac{1}{1-z} = 1 + z + z^2 + z^3 + \cdots .$$

Use this model, together with differentiation of series, to find the power series expansion about 0 for

$$\frac{1}{(1-w^2)^2} .$$

17. Use the idea of the last exercise to find the power series expansion about 0 of the function

$$\frac{1-z^2}{(1+z^2)^2} .$$

18. Write a `MatLab` routine to calculate the power series expansion of a given holomorphic function f about a base point P in the complex plane. Your routine should allow you to specify in advance the order of the partial sum (or Taylor polynomial) of the power series that you will generate.

19. Write a second `MatLab` routine to calculate the error term when calculating the Taylor polynomial in the last example. This will necessitate your specifying a disc of convergence on which to work.
20. A simple harmonic oscillator satisfies the differential equation

$$f''(z) + f(z) = 0.$$

Guess a solution $f(z) = \sum_{j=0}^{\infty} a_j z^j$. Plug this guess into the differential equation and solve for the a_j . What power series results? Can you recognize this series as a familiar function (or perhaps two functions) in closed form?

21. Apply the technique of the preceding exercise to the differential equation

$$f'(z) - 2f(z) = 0.$$

4.2 The Zeros of a Holomorphic Function

4.2.1 The Zero Set of a Holomorphic Function

Let f be a holomorphic function. If f is not identically zero, then it turns out that f cannot vanish at too many points. This once again bears out the dictum that holomorphic functions are a lot like polynomials. To give this notion a precise formulation, we need to recall the topological notion of connectedness (Section 1.2.2). An open set $W \subseteq \mathbb{C}$ is *connected* if it is not possible to find two disjoint, nonempty open sets U, V in \mathbb{C} such that $U \cap W \neq \emptyset$, $V \cap W \neq \emptyset$, and

$$W = (U \cap W) \cup (V \cap W). \quad (4.23)$$

[In the special context of open sets in the plane, it turns out that connectedness is equivalent to the condition that any two points of W may be connected by a curve that lies entirely in W —see the discussion in Section 1.2.3 on path-connectedness.] Now we have:

Discreteness of the Zeros of a Holomorphic Function

Let $U \subseteq \mathbb{C}$ be a connected (Section 1.2.2) open set and let $f : U \rightarrow \mathbb{C}$ be holomorphic. Let the zero set of f be $\mathcal{Z} = \{z \in U : f(z) = 0\}$. If there are a $z_0 \in U$ and $\{z_j\}_{j=1}^\infty \subseteq \mathcal{Z} \setminus \{z_0\}$ such that $z_j \rightarrow z_0$, then $f \equiv 0$ on U .

A full proof of this remarkable result may be found in [AHL] or [GRK]. The justification is as follows. Of course f must vanish at z_0 —say that it vanishes to order¹ $k > 0$. This means that $f(z) = (z - z_0)^k \cdot g(z)$ and g does not vanish at z_0 . But then observe that $g(z_j) = 0$ for $j = 1, 2, \dots$. It follows by continuity that $g(z_0) = 0$. That is a contradiction.

Let us formulate the result in topological terms. We recall (see [KRA2], [RUD1]) that a point z_0 is said to be an *accumulation point* of a set \mathcal{Z} if there is a sequence $\{z_j\} \subseteq \mathcal{Z} \setminus \{z_0\}$ with $\lim_{j \rightarrow \infty} z_j = z_0$. Then the theorem is equivalent to the statement: If $f : U \rightarrow \mathbb{C}$ is a holomorphic function on a connected (Section 1.2.2) open set U and if $\mathcal{Z} = \{z \in U : f(z) = 0\}$ has an accumulation point *in* U , then $f \equiv 0$.

4.2.2 Discrete Sets and Zero Sets

There is still more terminology concerning the discussion of the zero set of a holomorphic function in Section 4.2.1. A set S is said to be *discrete* if for each $s \in S$ there is an $\epsilon > 0$ such that $D(s, \epsilon) \cap S = \{s\}$.

People also say, in a slight abuse of language, that a discrete set has points that are “isolated” or that S contains only “isolated points.” The result in Section 4.2.1 thus asserts that if f is a nonconstant holomorphic function on a connected open set, then its zero set is discrete or, less formally, the zeros of f are isolated.

EXAMPLE 41 It is important to realize that the result in Section 4.2.1 does *not* rule out the possibility that the zero set of f can have accumulation points in $\mathbb{C} \setminus U$; in particular, a nonconstant holomorphic function on an open set U can indeed have zeros accumulating at a point of ∂U . Consider, for instance, the function $f(z) = \sin(1/[1 - z])$ on the unit disc. The zeros

¹If a holomorphic function vanishes at a point P , then it vanishes to a certain order (see Section 6.1.3). Thus $f(z) = (z - P)^k \cdot g(z)$ for some holomorphic function g that *does not* vanish at P . This claim follows from the theory of power series.

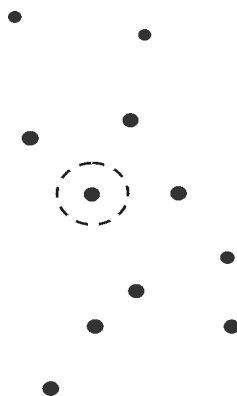


Figure 4.3: A discrete set.

of this f include $\{1 - 1/[n\pi]\}$, and these accumulate at the boundary point 1. Figure 4.3 illustrates a discrete set. Figure 4.4 shows a zero set with a boundary accumulation point. \square

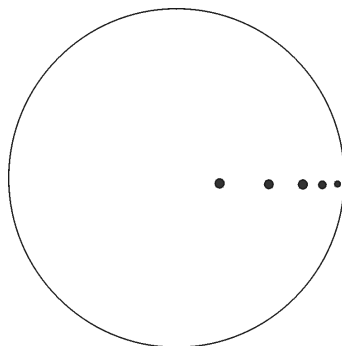


Figure 4.4: A zero set with a boundary accumulation point.

EXAMPLE 42 The function $g(z) = \sin z$ has zeros at $z = k\pi$. Since the domain of g is the entire plane, these infinitely many zeros have no accumulation point so there is no contradiction in that g is not identically zero.

By contrast, the domain $U = \{z = x + iy \in \mathbb{C} : -1 < x < 1, -1 < y < 1\}$ is bounded. If f is holomorphic on U then a holomorphic f can only have

finitely many zeros in any compact subset of U . If a holomorphic g has infinitely many zeros, then those zeros can only accumulate at a boundary point. Examples are

$$f(z) = \left(z - \frac{1}{2}\right)^2 \cdot \left(z + \frac{i}{2}\right)^3,$$

with zeros at $1/2$ and $-i/2$, and

$$g(z) = \cos\left(\frac{i}{i-z}\right).$$

Notice that the zeros of g are at $z_k = i\frac{(2k+1)\pi-2}{(2k+1)\pi}$. There are infinitely many of these zeros, and they accumulate *only* at i . \square

4.2.3 Uniqueness of Analytic Continuation

A consequence of the preceding basic fact (Section 4.2.1) about the zeros of a holomorphic function is this: Let $U \subseteq \mathbb{C}$ be a connected open set and $D(P, r) \subseteq U$. If f is holomorphic on U and $f|_{D(P, r)} \equiv 0$, then we may conclude that $f \equiv 0$ on U . This is so because the disc $D(P, r)$ certainly contains an interior accumulation point (merely take $z_j = P + r/j$ and $z_j \rightarrow z_0 = P$) hence f must be identically equal to 0.

Here are some further corollaries:

1. Let $U \subseteq \mathbb{C}$ be a connected open set. Let f, g be holomorphic on U . If $\{z \in U : f(z) = g(z)\}$ has an accumulation point in U , then $f \equiv g$. For simply apply our uniqueness result to the difference function $h(z) = f(z) - g(z)$.
2. Let $U \subseteq \mathbb{C}$ be a connected open set and let f, g be holomorphic on U . If $f \cdot g \equiv 0$ on U , then either $f \equiv 0$ on U or $g \equiv 0$ on U . To see this, we notice that if neither f nor g is identically 0 then there is either a point p at which $f(p) \neq 0$ or there is a point p' at which $g(p') \neq 0$. Say it is the former. Then, by continuity, $f(p) \neq 0$ on an entire disc centered at p . But then it follows, since $f \cdot g \equiv 0$, that $g \equiv 0$ on that disc. Thus it must be, by the remarks in the first paragraph of this section, that $g \equiv 0$.

3. We have the following powerful result:

Let $U \subseteq \mathbb{C}$ be connected and open and let f be holomorphic on U . If there is a $P \in U$ such that

$$\left(\frac{\partial}{\partial z}\right)^n f(P) = 0$$

for every $n \in \{0, 1, 2, \dots\}$, then $f \equiv 0$.

The reason for this result is simplicity itself: The power series expansion of f about P will have all zero coefficients. Since the series certainly converges to f on some small disc centered at P , the function is identically equal to 0 on that disc. Now, by our uniqueness result for zero sets, we conclude that f is identically 0.

4. If f and g are entire holomorphic functions and if $f(x) = g(x)$ for all $x \in \mathbb{R} \subseteq \mathbb{C}$, then $f \equiv g$. It also holds that functional identities that are true for all real values of the variable are also true for complex values of the variable (Figure 4.5). For instance,

$$\sin^2 z + \cos^2 z = 1 \quad \text{for all } z \in \mathbb{C} \quad (4.24)$$

because the identity is true for all $z = x \in \mathbb{R}$. This is an instance of the “principle of persistence of functional relations”—see [GRK].

Of course these statements are true because if U is a connected open set having nontrivial intersection with the x -axis and if f holomorphic on U vanishes on that intersection, then the zero set certainly has an interior accumulation point. Again, see Figure 4.5.

Exercises

1. Let f and g be entire functions and suppose that $f(x+ix^2) = g(x+ix^2)$ whenever x is real. Prove that $f(z) = g(z)$ for all z .
2. Let $p_n \in D$ be defined by $p_n = 1 - 1/n$, $n = 1, 2, \dots$. Suppose that f and g are holomorphic on the disc D and that $f(p_n) = g(p_n)$ for every n . Does it follow that $f \equiv g$?

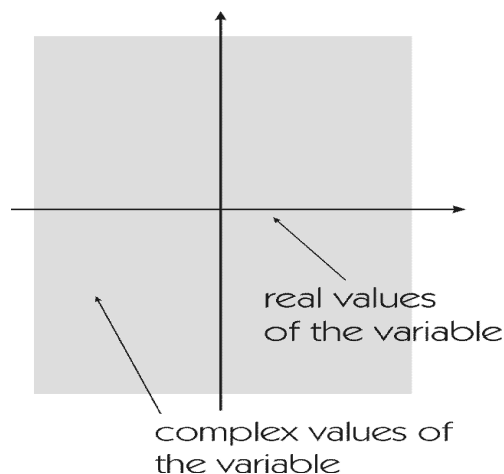


Figure 4.5: The principle of persistence of functional relations.

3. The real axis cannot be the zero set of a not-identically-zero holomorphic function on the entire plane. But it *can* be the zero set of a not-identically-zero harmonic function on the plane. Prove both of these statements.
4. Give an example of a holomorphic function on the disc D that vanishes on an infinite set in D but which is not identically zero.
5. Let f and g be holomorphic functions on the disc D . Let \mathcal{P} be the zero set of f and let \mathcal{Q} be the zero set of g . Is $\mathcal{P} \cup \mathcal{Q}$ the zero set of some holomorphic function on D ? Is $\mathcal{P} \cap \mathcal{Q}$ the zero set of some holomorphic function on D ? Is $\mathcal{P} \setminus \mathcal{Q}$ the zero set of some holomorphic function on D ?
6. Give an example of an entire function that vanishes at every point of the form $0 + ik$ and every point of the form $k + i0$, for $k \in \mathbb{Z}$.
7. Let $c \in \mathbb{C}$ satisfy $|c| < 1$. The function

$$\varphi_c(z) \equiv \frac{z - c}{1 - \bar{c}z}$$

is called a *Blaschke factor* at the point c . Verify these properties of φ_c :

- $|\varphi_c(z)| = 1$ whenever $|z| = 1$;
 - $|\varphi_c(z)| < 1$ whenever $|z| < 1$;
 - $\varphi_c(c) = 0$;
 - $\varphi_c \circ \varphi_{-c}(z) \equiv z$.
8. Give an example of a holomorphic function on $\Omega \equiv D \setminus \{0\}$ such that $f(1/n) = 0$ for $n = \pm 1, \pm 2, \dots$, yet f is not identically 0.
 9. Suppose that f is a holomorphic function on the disc and $f(z)/z \equiv 1$ for z real (with the meaning of this statement for $z = 0$ suitably interpreted). What can you conclude about f ?
 10. Let f, g be holomorphic on the disc D and suppose that $[f \cdot g](z) = 0$ for $z = 1/2, 1/3, 1/4, \dots$. Prove that either $f \equiv 0$ or $g \equiv 0$.
 11. Write a `MatLab` routine that will implement Newton's method to find the zeros of a given holomorphic function (see [BLK] for the basic idea of Newton's method). Enumerate the zeros by order of modulus.
 12. Refine the `MatLab` routine from the last exercise to calculate the *order* of each zero. You will want to exploit the following simple-minded observations:
 - (a) The holomorphic function f has a simple zero at P if and only if $f(P) = 0$ but $f'(P) \neq 0$.
 - (b) The holomorphic function f has a zero of order two at P if $f(P) = 0$, $f'(P) = 0$, yet $f''(P) \neq 0$.
 - (c) The holomorphic function f has a zero of order k at P if $f(P) = 0$, $f'(P) = 0, \dots, f^{(k-1)}(P) = 0$, yet $f^{(k)}(P) \neq 0$.
 13. The holomorphic function $f(z) = u(z) + iv(z) \approx (u(x, y), v(x, y))$, describes a fluid flow on the unit disc. The function f is of course conformal. What do the zeros of f signify from a physical point of view? According to our uniqueness theorem, the values $f(x + i0)$ uniquely determine f . What is the physical interpretation of this statement?
 14. Interpret the statement that if the zero set of a holomorphic function has an interior accumulation point then it is identically zero from a physical point of view. Refer to the preceding exercise.

Chapter 5

Isolated Singularities and Laurent Series

5.1 The Behavior of a Holomorphic Function near an Isolated Singularity

5.1.1 Isolated Singularities

It is often important to consider a function that is holomorphic on a punctured open set $U \setminus \{P\} \subset \mathbb{C}$. Refer to Figure 5.1.

In this chapter we shall obtain a new kind of infinite series expansion which generalizes the idea of the power series expansion of a holomorphic function about a (nonsingular) point—see Section 4.1.6. We shall in the process completely classify the behavior of holomorphic functions near an isolated singular point (Section 5.1.3).

5.1.2 A Holomorphic Function on a Punctured Domain

Let $U \subseteq \mathbb{C}$ be an open set and $P \in U$. Suppose that $f : U \setminus \{P\} \rightarrow \mathbb{C}$ is holomorphic. In this situation we say that f has an *isolated singular point* (or *isolated singularity*) at P . The implication of the phrase is usually just that f is defined and holomorphic on some such “deleted neighborhood” of P . The specification of the set U is of secondary interest; we wish to consider the behavior of f “near P .”

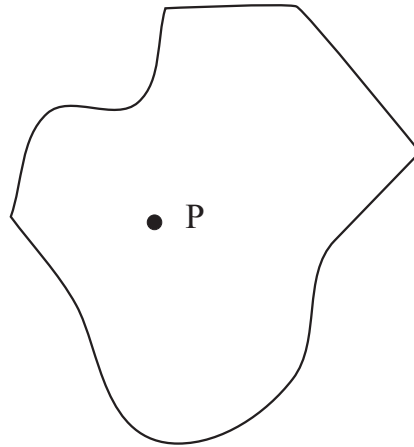


Figure 5.1: A punctured domain.

5.1.3 Classification of Singularities

There are three possibilities for the behavior of f near P that are worth distinguishing:

- (1) $|f(z)|$ is bounded on $D(P, r) \setminus \{P\}$ for some $r > 0$ with $D(P, r) \subseteq U$; that is, there is some $r > 0$ and some $M > 0$ such that $|f(z)| \leq M$ for all $z \in U \cap D(P, r) \setminus \{P\}$.
- (2) $\lim_{z \rightarrow P} |f(z)| = +\infty$.
- (3) Neither (1) nor (2).

Clearly these three possibilities cover all conceivable situations. It is our job now to identify extrinsically what each of these three situations entails.

5.1.4 Removable Singularities, Poles, and Essential Singularities

We shall see momentarily that, if case (1) holds, then f has a limit at P that extends f so that it is holomorphic on all of U . It is commonly said in this

circumstance that f has a *removable singularity* at P . In case **(2)**, we will say that f has a *pole* at P . In case **(3)**, the function f will be said to have an *essential singularity* at P . Our goal in this and the next subsection is to understand **(1)**–**(3)** in some further detail.

5.1.5 The Riemann Removable Singularities Theorem

Let $f : D(P, r) \setminus \{P\} \rightarrow \mathbb{C}$ be holomorphic and bounded. Then

(a) $\lim_{z \rightarrow P} f(z)$ exists.

(b) The function $\widehat{f} : D(P, r) \rightarrow \mathbb{C}$ defined by

$$\widehat{f}(z) = \begin{cases} f(z) & \text{if } z \neq P \\ \lim_{\zeta \rightarrow P} f(\zeta) & \text{if } z = P \end{cases}$$

is holomorphic.

The reason that this theorem is true is the following. We may assume without loss of generality—by a simple translation of coordinates—that $P = 0$. Now consider the auxiliary function $g(z) = z^2 \cdot f(z)$. Then one may verify by direct application of the derivative that g is continuously differentiable at all points—including the origin. Furthermore, we may calculate with $\partial/\partial\bar{z}$ to see that g satisfies the Cauchy-Riemann equations. Thus g is holomorphic. But the very definition of g shows that g vanishes to order 2 at 0. Thus the power series expansion of g about 0 cannot have a constant term and cannot have a linear term. It follows that

$$g(z) = a_2 z^2 + a_3 z^3 + a_4 z^4 + \cdots = z^2(a_2 + a_3 z + a_4 z^2 + \cdots) \equiv z^2 \cdot h(z).$$

Notice that the function h is holomorphic—we have in fact given its power series expansion explicitly. But now, for $z \neq 0$, $h(z) = g(z)/z^2 = f(z)$. Thus we see that h is the holomorphic continuation of f (across the singularity at 0) that we seek.

5.1.6 The Casorati-Weierstrass Theorem

If $f : D(P, r_0) \setminus \{P\} \rightarrow \mathbb{C}$ is holomorphic and P is an essential singularity of f , then $f(D(P, r) \setminus \{P\})$ is dense in \mathbb{C} for any $0 < r < r_0$.

The proof of this result is a nice application of the Riemann removable singularities theorem. For suppose to the contrary that $f(D(P, r) \setminus \{P\})$ is *not* dense in \mathbb{C} . This means that there is a disc $D(Q, s)$ that is *not* in the range of f . So consider the function

$$g(z) = \frac{1}{f(z) - Q}.$$

We see that the denominator of this function is bounded away from 0 (by s) hence the function g itself is bounded near P . So we may apply Riemann's theorem and conclude that g continues analytically across the point P . And the value of g near P cannot be 0. But then it follows that

$$f(z) = \frac{1}{g(z)} + Q$$

extends analytically across P . That contradicts the hypothesis that P is an essential singularity for f .

5.1.7 Concluding Remarks

Now we have seen that, at a removable singularity P , a holomorphic function f on $D(P, r_0) \setminus \{P\}$ can be continued to be holomorphic on all of $D(P, r_0)$. And, near an essential singularity at P , a holomorphic function g on $D(P, r_0) \setminus \{P\}$ has image that is dense in \mathbb{C} . The third possibility, that h has a *pole* at P , has yet to be described. Suffice it to say that, at a pole (case **(2)**), the limit of modulus the function is $+\infty$ hence the graph of the modulus of the function looks like a pole! See Figure 5.2. This case will be examined further in the next section.

We next develop a new type of doubly infinite series that will serve as a tool for understanding isolated singularities—especially poles.

Exercises

1. Discuss the singularities of these functions at 0:

$$(a) f(z) = \frac{z^2}{1 - \cos z}$$

$$(b) g(z) = \frac{\sin z}{z}$$

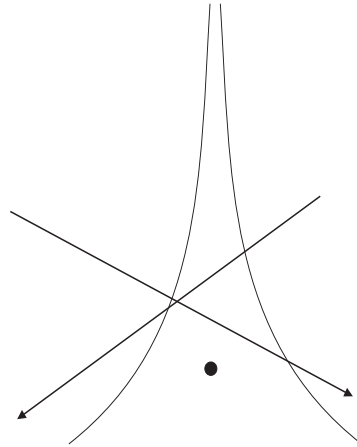


Figure 5.2: A pole.

$$(c) \quad h(z) = \frac{\sec z - 1}{\sin^2 z}$$

$$(d) \quad f(z) = \frac{\log(1+z)}{z^2}$$

$$(e) \quad g(z) = \frac{z^2}{e^z - 1}$$

$$(f) \quad h(z) = \frac{\sin z - z}{z^2}$$

$$(g) \quad f(z) = e^{1/z}$$

2. If f has a pole at P and g has a pole at P does it then follow that $f \cdot g$ has a pole at P ? How about $f + g$?
3. If f has a pole at P and g has an essential singularity at P does it then follow that $f \cdot g$ has an essential singularity at P ? How about $f + g$?
4. Suppose that f is holomorphic in a deleted neighborhood $D(P, r) \setminus \{P\}$ of P and that f is not bounded near P . Assume further that $(z - P)^2 \cdot f$ is bounded (near P). Prove that f has a pole at p . What happens if the exponent 2 is replaced by some other positive integer?
5. Suppose that f is holomorphic in a deleted neighborhood $D(P, r) \setminus \{P\}$

of P and that $(z-P)^k \cdot f$ is unbounded for every choice of positive integer k . What conclusion can you draw about the singularity of f at P ?

6. Write a **MatLab** routine to test whether a holomorphic function defined on a deleted neighborhood $D(0, r) \setminus \{0\}$ of the origin has a holomorphic continuation past 0. Of course use the Riemann removable singularities theorem as a tool.
7. Let f be a holomorphic function defined on a deleted neighborhood $D(0, r) \setminus \{0\}$ of the origin. Devise a **MatLab** routine to test whether f has a pole or an essential singularity at 0. [**Hint:** Bear in mind that a function *blows up* at a pole, whereas (by contrast) the function takes a dense set of values on any neighborhood of 0 when it has an essential singularity there. Use these facts as the basis for your **MatLab** testing routine.]
8. In the Riemann removable singularities theorem, the hypothesis of boundedness is not essential. Describe a weaker hypothesis that will give (with the same proof!) the same conclusion.
9. A differential equation describes an incompressible fluid flow in a deleted neighborhood of the point P in the complex plane. The solution of the equation exhibits a removable singularity at P . What does this tell you about the physical nature of the system?
10. A differential equation describes an incompressible fluid flow in a deleted neighborhood of the point P in the complex plane. The solution of the equation exhibits an essential pole at P . What does this tell you about the physical nature of the system?
11. A differential equation describes an incompressible fluid flow in a deleted neighborhood of the point P in the complex plane. The solution of the equation exhibits an essential singularity at P . What does this tell you about the physical nature of the system?

5.2 Expansion around Singular Points

5.2.1 Laurent Series

A *Laurent series* on $D(P, r)$ is a (formal) expression of the form

$$\sum_{j=-\infty}^{+\infty} a_j(z-P)^j. \quad (5.1)$$

Observe that the sum extends from $j = -\infty$ to $j = +\infty$. Further note that the individual summands are each defined for all $z \in D(P, r) \setminus \{P\}$.

5.2.2 Convergence of a Doubly Infinite Series

To discuss convergence of Laurent series, we must first make a general agreement as to the meaning of the convergence of a “doubly infinite” series $\sum_{j=-\infty}^{+\infty} \alpha_j$. We say that such a series *converges* if $\sum_{j=0}^{+\infty} \alpha_j$ and $\sum_{j=1}^{+\infty} \alpha_{-j} = \sum_{j=-\infty}^{-1} \alpha_j$ converge in the usual sense. In this case, we set

$$\sum_{-\infty}^{+\infty} \alpha_j = \left(\sum_{j=0}^{+\infty} \alpha_j \right) + \left(\sum_{j=1}^{+\infty} \alpha_{-j} \right). \quad (5.2)$$

Thus a doubly infinite series converges precisely when the sum of its “positive part” (that is., the terms of positive index) converges and the sum of its “negative part” (that is, the terms of negative index) converges.

We can now present the analogues for Laurent series of our basic results about power series.

5.2.3 Annulus of Convergence

The set of convergence of a Laurent series is either an open set of the form $\{z : 0 \leq r_1 < |z-P| < r_2\}$, together with perhaps some or all of the boundary points of the set, *or* a set of the form $\{z : 0 \leq r_1 < |z-P| < +\infty\}$, together with perhaps some or all of the boundary points of the set. Such an open set is called an *annulus* centered at P . We shall let

$$D(P, +\infty) = \{z : |z-P| < +\infty\} = \mathbb{C}, \quad (5.3)$$

$$D(P, 0) = \{z : |z-P| < 0\} = \emptyset, \quad (5.4)$$

and

$$\overline{D}(P, 0) = \{P\}. \quad (5.5)$$

As a result, all (open) annuli (plural of “annulus”) can be written in the form

$$D(P, r_2) \setminus \overline{D}(P, r_1), \quad 0 \leq r_1 \leq r_2 \leq +\infty. \quad (5.6)$$

In precise terms, the “domain of convergence” of a Laurent series is given as follows:

Let

$$\sum_{n=-\infty}^{+\infty} a_n(z-P)^n \quad (5.7)$$

be a doubly infinite series. There are (see (5.6)) unique nonnegative extended real numbers r_1 and r_2 (r_1 or r_2 may be $+\infty$) such that the series converges absolutely for all z with $r_1 < |z-P| < r_2$ and diverges for z with $|z-P| < r_1$ or $|z-P| > r_2$. Also, if $r_1 < s_1 \leq s_2 < r_2$, then $\sum_{n=-\infty}^{+\infty} |a_n(z-P)^n|$ converges uniformly on $\{z : s_1 \leq |z-P| \leq s_2\}$ and, consequently, $\sum_{n=-\infty}^{+\infty} a_n(z-P)^n$ converges absolutely and uniformly there.

5.2.4 Uniqueness of the Laurent Expansion

Let $0 \leq r_1 < r_2 \leq \infty$. If the Laurent series $\sum_{n=-\infty}^{+\infty} a_n(z-P)^n$ converges on $D(P, r_2) \setminus \overline{D}(P, r_1)$ to a function f , then, for any r satisfying $r_1 < r < r_2$, and each $n \in \mathbb{Z}$,

$$a_n = \frac{1}{2\pi i} \oint_{|\zeta-P|=r} \frac{f(\zeta)}{(\zeta-P)^{n+1}} d\zeta. \quad (5.8)$$

In particular, the a_n 's are uniquely determined by f . We prove this result in Section 5.6.

We turn now to establishing that convergent Laurent expansions of functions holomorphic on an annulus do in fact exist.

5.2.5 The Cauchy Integral Formula for an Annulus

Suppose that $0 \leq r_1 < r_2 \leq +\infty$ and that $f : D(P, r_2) \setminus \overline{D}(P, r_1) \rightarrow \mathbb{C}$ is holomorphic. Then, for each s_1, s_2 such that $r_1 < s_1 < s_2 < r_2$ and each $z \in D(P, s_2) \setminus \overline{D}(P, s_1)$, it holds that

$$f(z) = \frac{1}{2\pi i} \oint_{|\zeta-P|=s_2} \frac{f(\zeta)}{\zeta-z} d\zeta - \frac{1}{2\pi i} \oint_{|\zeta-P|=s_1} \frac{f(\zeta)}{\zeta-z} d\zeta. \quad (5.9)$$

The easiest way to confirm the validity of this formula is to use a little manipulation of the Cauchy formula that we already know. Examine Figure 5.3. It shows a classical Cauchy contour for a holomorphic function with *no singularity* on a neighborhood of the curve and its interior. Now we simply

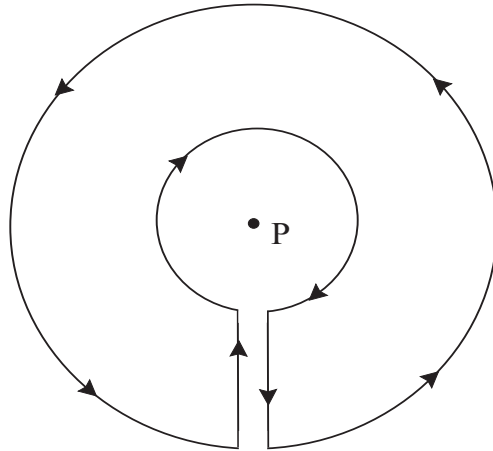


Figure 5.3: The Cauchy integral near an isolated singularity.

let the two vertical edges coalesce to form the Cauchy integral over two circles as in Figure 5.4.

5.2.6 Existence of Laurent Expansions

Now we have our main result:

If $0 \leq r_1 < r_2 \leq \infty$ and $f : D(P, r_2) \setminus \overline{D}(P, r_1) \rightarrow \mathbb{C}$ is holomorphic, then there exist complex numbers a_j such that

$$\sum_{j=-\infty}^{+\infty} a_j (z - P)^j \quad (5.10)$$

converges on $D(P, r_2) \setminus \overline{D}(P, r_1)$ to f . If $r_1 < s_1 < s_2 < r_2$, then the series converges absolutely and uniformly on $\overline{D}(P, s_2) \setminus D(P, s_1)$.

The series expansion is independent of s_1 and s_2 . In fact, for each fixed $n = 0, \pm 1, \pm 2, \dots$, the value of

$$a_n = \frac{1}{2\pi i} \oint_{|\zeta - P| = r} \frac{f(\zeta)}{(\zeta - P)^{n+1}} d\zeta \quad (5.11)$$

is independent of r provided that $r_1 < r < r_2$.

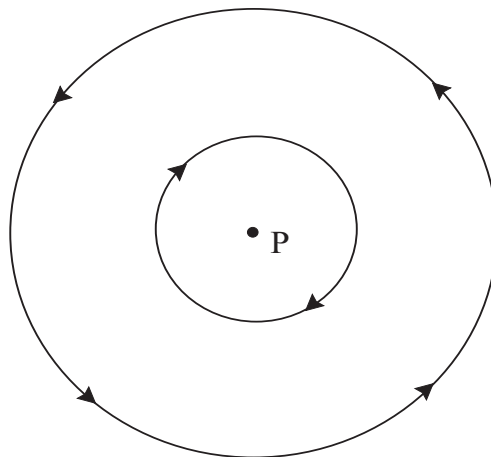


Figure 5.4: Annular Cauchy integral for an isolated singularity.

We may justify the Laurent expansion in the following manner.

If $0 \leq r_1 < s_1 < |z - P| < s_2 < r_2$, then the two integrals on the right-hand side of the equation in (5.9) can each be expanded in a series. For the first integral we have

$$\begin{aligned} \oint_{|\zeta-P|=s_2} \frac{f(\zeta)}{\zeta-z} d\zeta &= \oint_{|\zeta-P|=s_2} \frac{f(\zeta)}{1 - \frac{z-P}{\zeta-P}} \cdot \frac{1}{\zeta-P} d\zeta \\ &= \oint_{|\zeta-P|=s_2} \frac{f(\zeta)}{\zeta-P} \sum_{j=0}^{+\infty} \frac{(z-P)^j}{(\zeta-P)^j} d\zeta \\ &= \oint_{|\zeta-P|=s_2} \sum_{j=0}^{+\infty} \frac{f(\zeta)(z-P)^j}{(\zeta-P)^{j+1}} d\zeta, \end{aligned}$$

where the geometric series expansion of

$$\frac{1}{1 - (z-P)/(\zeta-P)}$$

converges because $|z-P|/|\zeta-P| = |z-P|/s_2 < 1$. In fact, since the value of $|(z-P)/(\zeta-P)|$ is independent of ζ , for $|\zeta-P| = s_2$, it follows that the geometric series converges uniformly.

Thus we may switch the order of summation and integration to obtain

$$\oint_{|\zeta-P|=s_2} \frac{f(\zeta)}{\zeta-z} d\zeta = \sum_{j=0}^{+\infty} \left(\oint_{|\zeta-P|=s_2} \frac{f(\zeta)}{(\zeta-P)^{j+1}} d\zeta \right) (z-P)^j.$$

For $s_1 < |z-P|$, similar arguments justify the formula

$$\begin{aligned} \oint_{|\zeta-P|=s_1} \frac{f(\zeta)}{\zeta-z} d\zeta &= - \oint_{|\zeta-P|=s_1} \frac{f(\zeta)}{1 - \frac{\zeta-P}{z-P}} \cdot \frac{1}{z-P} d\zeta \\ &= - \oint_{|\zeta-P|=s_1} \frac{f(\zeta)}{z-P} \sum_{j=0}^{+\infty} \frac{(\zeta-P)^j}{(z-P)^j} d\zeta \\ &= - \sum_{j=0}^{+\infty} \left[\oint_{|\zeta-P|=s_1} f(\zeta) \cdot (\zeta-P)^j d\zeta \right] (z-P)^{-j-1} \\ &= - \sum_{j=-\infty}^{-1} \left[\oint_{|\zeta-P|=s_1} \frac{f(\zeta)}{(\zeta-P)^{j+1}} d\zeta \right] (z-P)^j. \end{aligned}$$

Thus

$$\begin{aligned} 2\pi i f(z) &= \sum_{j=-\infty}^{-1} \left[\oint_{|\zeta-P|=s_1} \frac{f(\zeta)}{(\zeta-P)^{j+1}} d\zeta \right] (z-P)^j \\ &\quad + \sum_{j=0}^{+\infty} \left[\oint_{|\zeta-P|=s_2} \frac{f(\zeta)}{(\zeta-P)^{j+1}} d\zeta \right] (z-P)^j, \end{aligned}$$

as desired.

Certainly one of the important benefits of the proof we have just presented is that we have an explicit formula for the coefficients of the Laurent expansion:

$$a_j = \frac{1}{2\pi i} \oint_{\partial D(P,r)} \frac{f(\zeta)}{(\zeta-P)^{j+1}} d\zeta, \quad \text{any } r_1 < r < r_2.$$

In Section 5.3.2 we shall give an even more practical means, with examples, for the calculation of Laurent coefficients.

5.2.7 Holomorphic Functions with Isolated Singularities

Now let us specialize what we have learned about Laurent series expansions to the case of $f : D(P, r) \setminus \{P\} \rightarrow \mathbb{C}$ holomorphic, that is, to a holomorphic function with an isolated singularity. Thus we will be considering the Laurent expansion on a degenerate annulus of the form $D(P, r) \setminus \overline{D}(P, 0)$.

Let us review: If $f : D(P, r) \setminus \{P\} \rightarrow \mathbb{C}$ is holomorphic, then f has a unique Laurent series expansion

$$f(z) = \sum_{j=-\infty}^{\infty} a_j (z - P)^j \quad (5.12)$$

that converges absolutely for $z \in D(P, r) \setminus \{P\}$. The convergence is uniform on compact subsets of $D(P, r) \setminus \{P\}$. The coefficients are given by

$$a_j = \frac{1}{2\pi i} \oint_{\partial D(P, s)} \frac{f(\zeta)}{(\zeta - P)^{j+1}} d\zeta, \quad \text{any } 0 < s < r. \quad (5.13)$$

5.2.8 Classification of Singularities in Terms of Laurent Series

There are three mutually exclusive possibilities for the Laurent series

$$\sum_{n=-\infty}^{\infty} a_n (z - P)^n \quad (5.14)$$

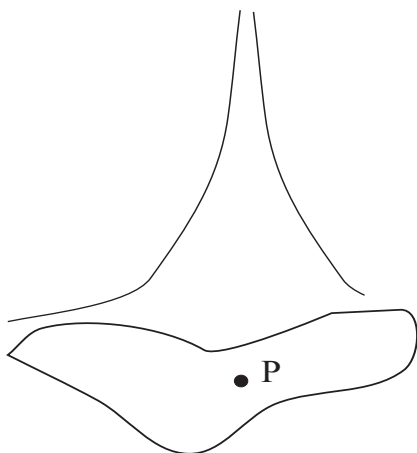
about an isolated singularity P :

(5.15) $a_n = 0$ for all $n < 0$.

(5.16) For some $k \geq 1$, $a_n = 0$ for all $-\infty < n < -k$, but $a_{-k} \neq 0$.

(5.17) Neither **(i)** nor **(ii)** applies.

These three cases correspond exactly to the three types of isolated singularities that we discussed in Section 5.1.3: case (5.15) occurs if and only if P is a removable singularity; case (5.16) occurs if and only if P is a pole (of order k); and case (5.17) occurs if and only if P is an essential singularity.

Figure 5.5: A pole at P .

To put this matter in other words: In case (5.15), we have a power series that converges, of course, to a holomorphic function. In case (5.16), our Laurent series has the form

$$\sum_{j=-k}^{\infty} a_j(z-P)^j = (z-P)^{-k} \sum_{j=-k}^{\infty} a_j(z-P)^{j+k} = (z-P)^{-k} \sum_{j=0}^{\infty} a_{j-k}(z-P)^j. \quad (5.18)$$

Since $a_{-k} \neq 0$, we see that, for z near P , the function defined by the series behaves like $a_{-k} \cdot (z-P)^{-k}$. In short, the function (in absolute value) blows up like $|z-P|^{-k}$ as $z \rightarrow P$. A graph in $(|z|, |f(z)|)$ -space would exhibit a “pole-like” singularity. This is the source of the terminology “pole.” See Figure 5.5. Case (5.17), corresponding to an essential singularity, is much more complicated; in this case there are infinitely many negative terms in the Laurent expansion and, by Casorati-Weierstrass (Section 5.1.6), they interact in a complicated fashion.

Picard’s Great Theorem (see Glossary of Terms) tells us more about the behavior of a holomorphic function near an essential singularity.

Exercises

1. Derive the Laurent expansion for the function $g(z) = e^{1/z}$ about $z = 0$. Use your knowledge of the exponential function plus substitution.
2. Derive the Laurent expansion for the function $h(z) = \frac{\sin z}{z^3}$ about $z = 0$.
3. Derive the Laurent expansion for the function $f(z) = \frac{\sin z}{\cos z}$ about $z = \pi/2$. Use long division.

4. Verify that the functions

$$f(z) = e^{1/z}$$

and

$$g(z) = \cos(1/z)$$

each have an essential singularity at $z = 0$. Now determine the nature of the behavior of f/g at 0.

5. Suppose that the function f has an essential singularity at 0. Does it then follow that $1/f$ has an essential singularity at 0?
6. It is impossible to use a computer to determine whether a given function f has Laurent expansion with infinitely many terms of negative index at a given point P . Discuss other means for using `MatLab` to test f for the various types of singularities at P .
7. Explain using Laurent series why f and g could both have essential singularities at P yet $f - g$ may not have such a singularity at P . Does a similar analysis apply to $f \cdot g$?
8. Explain using Laurent series why f and g could both have poles at P yet $f - g$ may not have such a singularity at P . Does a similar analysis apply to $f \cdot g$?
9. Give an example of functions f and g , each of which has an essential singularity at 0, yet $f + g$ has a pole of order 1 at 0.
10. An incompressible fluid flow has singularity at the origin having the form

$$\frac{\sin z - z}{z^5}.$$

Discuss the nature of this singularity. What will be the behavior of the flow near the origin?

5.3 Examples of Laurent Expansions

5.3.1 Principal Part of a Function

When f has a pole at P , it is customary to call the negative power part of the Laurent expansion of f around P the *principal part* of f at P . (Occasionally we shall also use the terminology “Laurent polynomial.”) That is, if

$$f(z) = \sum_{n=-k}^{\infty} a_n(z-P)^n \quad (5.19)$$

for z near P , then the *principal part* of f at P is

$$\sum_{n=-k}^{-1} a_n(z-P)^n. \quad (5.20)$$

EXAMPLE 43 The Laurent expansion about 0 of the function $f(z) = (z^2 + 1)/\sin(z^3)$ is

$$\begin{aligned} f(z) &= (z^2 + 1) \cdot \frac{1}{\sin(z^3)} \\ &= (z^2 + 1) \cdot \frac{1}{z^3 - z^9/3! + z^{15}/5! - + \dots} \\ &= (z^2 + 1) \cdot \frac{1}{z^3} \cdot \frac{1}{1 - z^6/3! + z^{12}/5! - + \dots} \\ &= (z^2 + 1) \cdot \frac{1}{z^3} \cdot \left(1 + \frac{z^6}{3!} - + \dots \right) \\ &= \frac{1}{z^3} + \frac{1}{z} + (\text{a holomorphic function}). \end{aligned}$$

The principal part of f is $1/z^3 + 1/z$. □

EXAMPLE 44 For a second example, consider the function $f(z) = (z^2 + 2z +$

2) $\sin(1/(z+1))$. Its Laurent expansion about the point -1 is

$$\begin{aligned} f(z) &= ((z+1)^2 + 1) \cdot \left[\frac{1}{z+1} - \frac{1}{6(z+1)^3} + \frac{1}{120(z+1)^5} \right. \\ &\quad \left. - \frac{1}{5040(z+1)^7} + \dots \right] \\ &= (z+1) + \frac{5}{6} \frac{1}{(z+1)} - \frac{19}{120} \frac{1}{(z+1)^3} + \frac{41}{5040} \frac{1}{(z+1)^5} - + \dots \end{aligned}$$

The principal part of f at the point -1 is

$$\frac{5}{6} \frac{1}{(z+1)} - \frac{19}{120} \frac{1}{(z+1)^3} + \frac{41}{5040} \frac{1}{(z+1)^5} - + \dots \quad (5.21)$$

□

As with power series (see Section 4.1.6), we can sometimes use calculus or algebra tricks to derive a Laurent series expansion. An example illustrates the idea:

EXAMPLE 45 Let us derive the Laurent series expansion about 0 of the function

$$f(z) = \frac{1}{z^2(z+1)}.$$

We use the method of partial fractions (from calculus) to write the function as

$$f(z) = -\frac{1}{z} + \frac{1}{z^2} + \frac{1}{z+1} = -\frac{1}{z} + \frac{1}{z^2} + \frac{1}{1-(-z)}.$$

Thus we see that the Laurent expansion of f about 0 is

$$f(z) = \frac{1}{z^2} - \frac{1}{z} + 1 + (-z) + (-z)^2 + (-z)^3 + \dots$$

In particular, the principal part of f at 0 is $1/z^2 - 1/z$ and the residue is -1 . □

5.3.2 Algorithm for Calculating the Coefficients of the Laurent Expansion

Let f be holomorphic on $D(P, r) \setminus \{P\}$ and suppose that f has a pole of order k at P . Then the Laurent series coefficients a_n of f expanded about the point P , for $j = -k, -k + 1, -k + 2, \dots$, are given by the formula

$$a_j = \frac{1}{(k+j)!} \left(\frac{\partial}{\partial z} \right)^{k+j} \left((z-P)^k \cdot f \right) \Big|_{z=P}. \quad (5.22)$$

We begin by illustrating this formula, and provide the justification a bit later.

EXAMPLE 46 Let $f(z) = \cot z$. Let us calculate the Laurent coefficients of negative index for f at the point $P = 0$.

We first notice that

$$\cot z = \frac{\cos z}{\sin z}.$$

Since $\cos z = 1 - z^2/2! + \dots$ and $\sin z = z - z^3/3! + \dots$, we see immediately that, for $|z|$ small, $\cot z = \cos z / \sin z \approx 1/z$ so that f has a pole of order 1 at 0. Thus, in our formula for the Laurent coefficients, $k = 1$. Also the only Laurent coefficient of negative index is $n = -1$. [We anticipate from this calculation that the coefficient of z^{-1} will be 1. This perception will be borne out in our calculation.]

Now we see, by (5.22), that

$$a_{-1} = \frac{1}{0!} \left(\frac{\partial}{\partial z} \right)^0 \left(z \cdot \frac{\cos z}{\sin z} \right) \Big|_{z=0} = \left(z \cdot \frac{\cos z}{\sin z} \right) \Big|_{z=0}.$$

It is appropriate to apply l'Hôpital's Rule to evaluate this last expression. Thus we have

$$\frac{\cos z - z \cdot \sin z}{\cos z} \Big|_{z=0} = 1.$$

Not surprisingly, we find that the “pole” term of the Laurent expansion of this function f about 0 is $1/z$. We say “not surprisingly” because $\cos z = 1 - \dots$ and $\sin z = z - \dots$ and hence we expect that $\cot z = 1/z + \dots$. \square

We invite the reader to use the technique of the last example to calculate a_0 for the given function f . Of course you will find l'Hôpital's rule useful. You should not be surprised to learn that $a_0 = 0$ (and we say “not surprised” because you could have anticipated this result using long division).

EXAMPLE 47 Let us use formula (5.22) to calculate the negative Laurent coefficients of the function $g(z) = z^2/(z-1)^2$ at the point $P = 1$.

It is clear that the pole at $P = 1$ has order $k = 2$. Thus we calculate

$$a_{-2} = \frac{1}{0!} \left(\frac{\partial}{\partial z} \right)^0 \left((z-1)^2 \cdot \frac{z^2}{(z-1)^2} \right) \Big|_{z=1} = z^2 \Big|_{z=1} = 1$$

and

$$a_{-1} = \frac{1}{1!} \left(\frac{\partial}{\partial z} \right)^1 \left((z-1)^2 \cdot \frac{z^2}{(z-1)^2} \right) \Big|_{z=1} = \frac{\partial}{\partial z} z^2 \Big|_{z=1} = 2z \Big|_{z=1} = 2.$$

Of course this result may be derived by more elementary means, using just algebra:

$$\frac{z^2}{(z-1)^2} = \frac{(z-1)^2}{(z-1)^2} + \frac{2z-1}{(z-1)^2} = 1 + \frac{2z-2}{(z-1)^2} + \frac{1}{(z-1)^2} = 1 + \frac{2}{z-1} + \frac{1}{(z-1)^2}.$$

□

The justification for formula (5.22) is simplicity itself. Suppose that f has a pole of order k at the point P . We may write

$$f(z) = (z-P)^{-k} \cdot h(z),$$

where h is holomorphic near P . Writing out the ordinary power series expansion of h , we find that

$$\begin{aligned} f(z) &= (z-P)^{-k} \cdot (a_0 + a_1(z-P) + a_2(z-P)^2 + \cdots) \\ &= \frac{a_0}{(z-P)^k} + \frac{a_1}{(z-P)^{k-1}} + \frac{a_2}{(z-P)^{k-2}} + \cdots \end{aligned}$$

So the $-(k-j)$ th Laurent coefficient of f is just the same as the j th power series coefficient of h . That is the key to our calculation, because

$$h(z) = (z-P)^k \cdot f(z),$$

and thus formula (5.22) is immediate.

Exercises

1. Calculate the Laurent series of the function $f(z) = \frac{z - \sin z}{z^6}$ at $z = \pi/2$.
2. Calculate the Laurent series of the function $g(z) = \frac{\ln z}{(z-1)^3}$ about the point $z = 1$.
3. Calculate the Laurent series of the function $\sin(1/z)$ about the point $z = 0$.
4. Calculate the Laurent series of the function $\tan z$ about the points $z = 0$, $z = \pi/2$ and $z = \pi$.
5. Suppose that f has a pole of order 1 at $z = 0$. What can you say about the behavior of $g(z) = e^{f(z)}$ at $z = 0$?
6. Suppose that f has an essential singularity at $z = 0$. What can you say about the behavior of $h(z) = e^{f(z)}$ at $z = 0$.
7. Let U be an open region in the plane. Let \mathcal{M} denote the collection of functions on U that has a discrete set of poles and is holomorphic elsewhere (we allow the possibility that the function may have *no* poles). Explain why \mathcal{M} is closed under addition, subtraction, multiplication, and division.
8. Consider Exercise 7 with the word “pole” replaced by “essential singularity.” Does any part of the conclusion of that exercise still hold? Why or why not?
9. Let $P = 0$. Classify each of the following as having a removable singularity, a pole, or an essential singularity at P :

(a) $\frac{1}{z}$,

(b) $\sin \frac{1}{z}$,

(c) $\frac{1}{z^3} - \cos z$,

(d) $z \cdot e^{1/z} \cdot e^{-1/z^2}$,

(e) $\frac{\sin z}{z}$,

- (f) $\frac{\cos z}{z}$,
- (g) $\frac{\sum_{k=2}^{\infty} 2^k z^k}{z^3}$.

10. Prove that

$$\sum_{n=1}^{\infty} 2^{-(2^n)} \cdot z^{-n}$$

converges for $z \neq 0$ and defines a function which has an essential singularity at $P = 0$.

11. A Laurent series converges on an annular region. Give examples to show that the set of convergence for a Laurent series can include some of the boundary, all of the boundary, or none of the boundary.
12. Calculate the annulus of convergence (including any boundary points) for each of the following Laurent series:

- (a) $\sum_{n=-\infty}^{\infty} 2^{-n} z^n$,
- (b) $\sum_{n=0}^{\infty} 4^{-n} z^n + \sum_{n=-\infty}^{-1} 3^n z^n$,
- (c) $\sum_{n=1}^{\infty} z^n / n^2$,
- (d) $\sum_{n=-\infty, n \neq 0}^{\infty} z^n / n^n$,
- (e) $\sum_{n=-\infty}^{10} z^n / |n|!$ ($0! = 1$),
- (f) $\sum_{n=-20}^{\infty} n^2 z^n$.

13. Use formal algebra to calculate the first four terms of the Laurent series expansion of each of the following functions:

- (a) $\tan z \equiv (\sin z / \cos z)$ about $\pi/2$,
- (b) $e^z / \sin z$ about 0,
- (c) $e^z / (1 - e^z)$ about 0,
- (d) $\sin(1/z)$ about 0,
- (e) $z(\sin z)^{-2}$ about 0,
- (f) $z^2(\sin z)^{-3}$ about 0.

For each of these functions, identify the type of singularity at the point about which the function has been expanded.

14. An incompressible fluid flow has the form $f(z) = [\cos z - 1]/z^3$. Calculate the principal part at the origin. What does the principal part tell us about the flow?

5.4 The Calculus of Residues

5.4.1 Functions with Multiple Singularities

It turns out to be useful, especially in evaluating various types of integrals, to consider functions that have more than one “singularity.” We want to consider the following general question:

Suppose that $f : U \setminus \{P_1, P_2, \dots, P_n\} \rightarrow \mathbb{C}$ is a holomorphic function on an open set $U \subseteq \mathbb{C}$ with finitely many distinct points P_1, P_2, \dots, P_n removed. Suppose further that

$$\gamma : [0, 1] \rightarrow U \setminus \{P_1, P_2, \dots, P_n\} \quad (5.23)$$

is a piecewise C^1 closed curve (Section 2.3.3) that (typically) “surrounds” some of the points P_1, \dots, P_n (Figure 5.6). Then how is $\oint_{\gamma} f$ related to the behavior of f near the points P_1, P_2, \dots, P_n ?

The first step is to restrict our attention to open sets U for which $\oint_{\gamma} f$ is necessarily 0 if P_1, P_2, \dots, P_n are removable singularities of f . See the next section.

5.4.2 The Concept of Residue

Suppose that U is a domain, $P \in U$, and f is a function holomorphic on $U \setminus \{P\}$ with a pole at P . Let γ be a simple, closed curve in U that surrounds P . And let $D(P, r)$ be a small disc, centered at P , that lies inside γ . Then certainly, by the usual Cauchy theory,

$$\frac{1}{2\pi i} \oint_{\gamma} f(z) dz = \frac{1}{2\pi i} \oint_{\partial D(P, r)} f(z) dz.$$

But more is true. Let a_{-1} be the -1 coefficient of the Laurent expansion of f about P . Then in fact

$$\begin{aligned} \frac{1}{2\pi i} \oint_{\gamma} f(z) dz &= \frac{1}{2\pi i} \oint_{\partial D(P,r)} f(z) dz \\ &= \frac{1}{2\pi i} \oint_{\partial D(P,r)} \frac{a_{-1}}{z-P} dz = a_{-1}. \end{aligned} \quad (5.24)$$

We call the value a_{-1} the *residue* of f at the point P .

The justification for formula (5.24) is the following. Observe that, with the parametrization $\mu(t) = P + re^{it}$ for $\partial D(P, r)$, we see for $n \neq -1$ that

$$\oint_{\partial D(P,r)} (z-P)^n dz = \int_0^{2\pi} (re^{it})^n \cdot rie^{it} dt = r^{n+1}i \int_0^{2\pi} e^{i(n+1)t} dt = 0.$$

It is important in this last calculation that $n \neq -1$. If instead $n = -1$ then the integral turns out to be

$$i \int_0^{2\pi} 1 dt = 2\pi i.$$

This information is critical because if we are integrating a meromorphic function $f(z) = \sum_{n=-\infty}^{\infty} a_n(z-P)^n$ around the contour $\partial D(P, r)$ then the result is

$$\begin{aligned} \oint_{\partial D(P,r)} f(z) dz &= \oint_{\partial D(P,r)} \sum_{n=-\infty}^{\infty} a_n(z-P)^n = \sum_{n=-\infty}^{\infty} a_n \oint_{\partial D(P,r)} (z-P)^n dz \\ &= a_{-1} \oint_{\partial D(P,r)} (z-P)^{-1} dz = 2\pi i a_{-1}. \end{aligned}$$

In other words,

$$a_{-1} = \frac{1}{2\pi i} \oint_{\partial D(P,r)} f(z) dz.$$

We will make incisive use of this information in the succeeding sections.

5.4.3 The Residue Theorem

Suppose that $U \subseteq \mathbb{C}$ is a simply connected open set in \mathbb{C} , and that P_1, \dots, P_n are distinct points of U . Suppose that $f : U \setminus \{P_1, \dots, P_n\} \rightarrow \mathbb{C}$ is a holomorphic function and γ is a simple, closed, positively oriented, piecewise C^1 curve in $U \setminus \{P_1, \dots, P_n\}$. Set

R_j = the coefficient of $(z - P_j)^{-1}$
in the Laurent expansion of f about P_j . (5.25)

Then

$$\frac{1}{2\pi i} \oint_{\gamma} f = \sum_{j=1}^n R_j \cdot \left(\frac{1}{2\pi i} \oint_{\gamma} \frac{1}{\zeta - P_j} d\zeta \right). \quad (5.26)$$

The rationale behind this residue formula is straightforward from the picture. Examine Figure 5.6. It shows the curve γ and the poles P_1, \dots, P_n . Figure 5.7 exhibits a small circular contour around each pole. And Figure 5.8 shows our usual trick of connecting up the contours. The integral around the big, conglomerate contour in Figure 5.8 (including γ , the integrals around each of the circular arcs, and the integrals along the connecting segments) is equal to 0. This demonstrates that

The integral of f around γ is equal to the sum of the integrals around each of the circles around the P_n .

If we let C_j be the circle around P_j , oriented in the counterclockwise direction as usual, then

$$\frac{1}{2\pi i} \oint_{\gamma} f(z) dz = \sum_{j=1}^n R_j \left(\frac{1}{2\pi i} \oint_{C_j} \frac{1}{\zeta - P_j} d\zeta \right). \quad (5.27)$$

5.4.4 Residues

The result just stated is used so often that some special terminology is commonly used to simplify its statement. First, the number R_j is usually called the *residue* of f at P_j , written $\text{Res}_f(P_j)$. Note that this terminology of considering the number R_j attached to the point P_j makes sense because $\text{Res}_f(P_j)$ is completely determined by knowing f in a small neighborhood of P_j . In particular, the value of the residue does not depend on what the other points P_k , $k \neq j$, might be, or on how f behaves near those points.

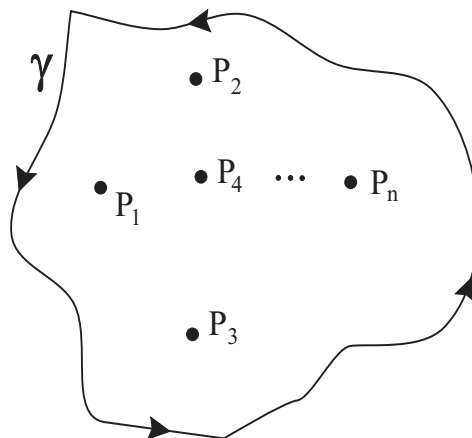
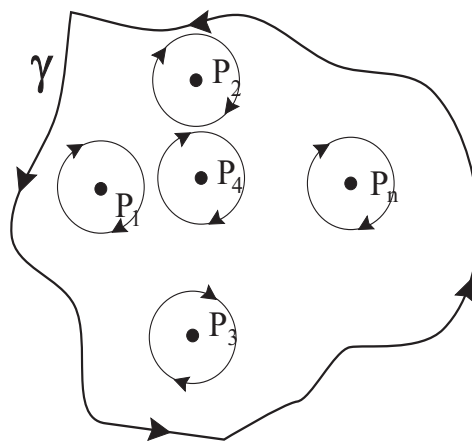
Figure 5.6: A curve γ with poles inside.

Figure 5.7: A small circle about each pole.

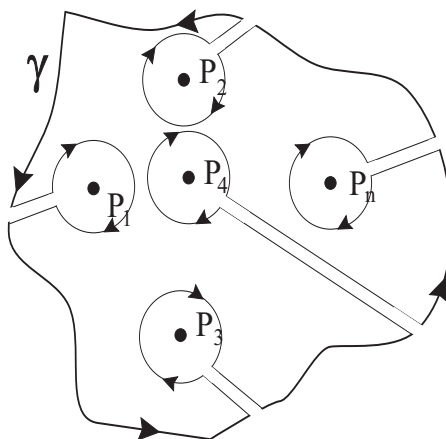


Figure 5.8: Stitching together the circles.

5.4.5 The Index or Winding Number of a Curve about a Point

The second piece of terminology associated to our result deals with the integrals that appear on the right-hand side of equation (5.27).

If $\gamma : [a, b] \rightarrow \mathbb{C}$ is a piecewise C^1 closed curve and if $P \notin \tilde{\gamma} \equiv \gamma([a, b])$, then the *index of γ with respect to P* , written $\text{Ind}_\gamma(P)$, is defined to be the number

$$\frac{1}{2\pi i} \oint_\gamma \frac{1}{\zeta - P} d\zeta. \quad (5.28)$$

The index is also sometimes called the “winding number of the curve γ about the point P .” It is a fact that $\text{Ind}_\gamma(P)$ is always an integer. Figure 5.9 illustrates the index of various curves γ with respect to different points P . Intuitively, the index measures the number of times the curve wraps around P , with counterclockwise being the positive direction of wrapping and clockwise being the negative.

The fact that the index is an integer-valued function suggests that the index counts the topological winding of the curve γ . Note in particular that a curve that traces a circle about the origin k times in a counterclockwise direction has index k with respect to the origin; a curve that traces a circle about the origin k times in a clockwise direction has index $-k$ with respect to the origin. The general fact that the index is integer valued, and counts the

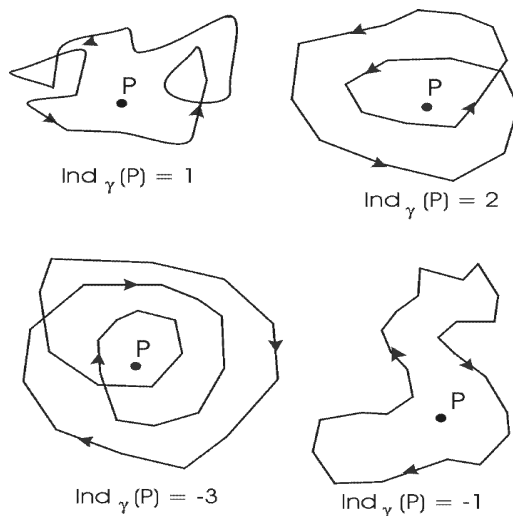


Figure 5.9: Examples of the index of a curve.

winding number, follows from these two simple observations by deformation. The index, or winding number, will prove to be an important geometric device.

5.4.6 Restatement of the Residue Theorem

Using the notation of residue and index, the Residue Theorem's formula becomes

$$\oint_{\gamma} f = 2\pi i \cdot \sum_{j=1}^n \text{Res}_f(P_j) \cdot \text{Ind}_{\gamma}(P_j). \quad (5.29)$$

People sometimes state this formula informally as “the integral of f around γ equals $2\pi i$ times the sum of the residues counted according to the index of γ about the singularities.”

In practice, when we apply the residue theorem, we use a simple, closed, positively-oriented curve γ . Thus the index of γ about any point in its interior is just 1. And therefore we use the ideas of Section 5.4.3 and replace γ with a small circle about each pole of the function (which of course will also have index equal to 1 with respect to the point at its center).

5.4.7 Method for Calculating Residues

We need a method for calculating residues.

Let f be a function with a pole of order k at P . Then

$$\operatorname{Res}_f(P) = \frac{1}{(k-1)!} \left(\frac{\partial}{\partial z} \right)^{k-1} \left[(z-P)^k f(z) \right] \Big|_{z=P}. \quad (5.30)$$

This is just a special case of the formula (5.22).

5.4.8 Summary Charts of Laurent Series and Residues

We provide two charts, the first of which summarizes key ideas about Laurent coefficients and the second of which contains key ideas about residues.

Poles and Laurent Coefficients

Item	Formula
j th Laurent coefficient of f with pole of order k at P	$\frac{1}{(k+j)!} \frac{d^{k+j}}{dz^{k+j}} [(z-P)^k \cdot f] \Big _{z=P}$
residue of f with a pole of order k at P	$\frac{1}{(k-1)!} \frac{d^{k-1}}{dz^{k-1}} [(z-P)^k \cdot f] \Big _{z=P}$
order of pole of f at P	least integer $k \geq 0$ such that $(z-P)^k \cdot f$ is bounded near P
order of pole of f at P	$\lim_{z \rightarrow P} \left \frac{\log f(z) }{\log z-P } \right $

Techniques for Finding the Residue at P

Function	Type of Pole	Calculation
$f(z)$	simple	$\lim_{z \rightarrow P} (z - P) \cdot f(z)$
$f(z)$	pole of order k k is the least integer such that $\lim_{z \rightarrow P} \mu(z)$ exists, where $\mu(z) = (z - P)^k f(z)$	$\lim_{z \rightarrow P} \frac{\mu^{(k-1)}(z)}{(k-1)!}$
$\frac{m(z)}{n(z)}$	$m(P) \neq 0, n(z) = 0, n'(P) \neq 0$	$\frac{m(P)}{n'(P)}$
$\frac{m(z)}{n(z)}$	m has zero of order k at P n has zero of order $(k+1)$ at P	$(k+1) \cdot \frac{m^{(k)}(P)}{n^{(k+1)}(P)}$
$\frac{m(z)}{n(z)}$	m has zero of order r at P n has zero of order $(k+r)$ at P	$\lim_{z \rightarrow P} \frac{\mu^{(k-1)}(z)}{(k-1)!},$ $\mu(z) = (z - P)^k \frac{m(z)}{n(z)}$

Exercises

1. Calculate the residue of the function $f(z) = \cot z$ at $z = 0$.
2. Calculate the residue of the function $h(z) = \tan z$ at $z = \pi/2$.
3. Calculate the residue of the function $g(z) = e^{1/z}$ at $z = 0$.

4. Calculate the residue of the function $f(z) = \cot^2 z$ at $z = 0$.
5. Calculate the residue of the function $g(z) = \sin(1/z)$ at $z = 0$.
6. Calculate the residue of the function $h(z) = \tan(1/z)$ at $z = 0$.
7. If the function f has residue a at $z = 0$ and the function g has residue b at $z = 0$ then what can you say about the residue of f/g at $z = 0$? What about the residue of $f \cdot g$ at $z = 0$?
8. Let f and g be as in Exercise 7. Describe the residues of $f + g$ and $f - g$ at $z = 0$.
9. Calculate the residue of $f_k(z) = z^k$ for $k \in \mathbb{Z}$. Explain the different answers for different ranges of k .
10. Is the residue of a function f at an essential singularity always equal to 0? Why or why not?
11. Use the calculus of residues to compute each of the following integrals:

(a) $\frac{1}{2\pi i} \oint_{\partial D(0,5)} f(z) dz$ where $f(z) = z/[(z+1)(z+2i)]$,

(b) $\frac{1}{2\pi i} \oint_{\partial D(0,5)} f(z) dz$ where $f(z) = e^z/[(z+1)\sin z]$,

(c) $\frac{1}{2\pi i} \oint_{\partial D(0,8)} f(z) dz$ where $f(z) = \cot z/[(z-6i)^2 + 64]$,

(d) $\frac{1}{2\pi i} \oint_{\gamma} f(z) dz$ where $f(z) = \frac{e^z}{z(z+1)(z+2)}$ and γ is the negatively (clockwise) oriented triangle with vertices $1 \pm i$ and -3 ,

(e) $\frac{1}{2\pi i} \oint_{\gamma} f(z) dz$ where $f(z) = \frac{e^z}{(z+3i)^2(z+3)^2(z+4)}$ and γ is the negatively oriented rectangle with vertices $2 \pm i, -8 \pm i$,

(f) $\frac{1}{2\pi i} \oint_{\gamma} f(z) dz$ where $f(z) = \frac{\cos z}{z^2(z+1)^2(z+i)}$ and γ is as in Figure 5.10.

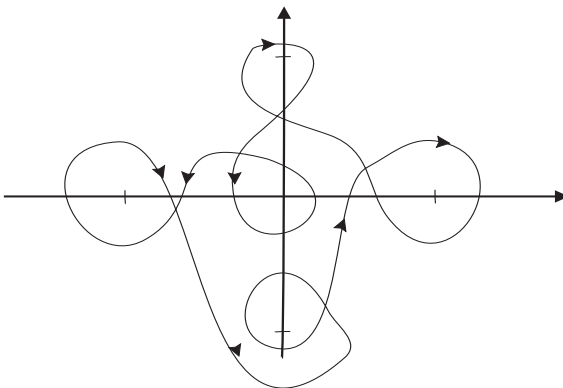


Figure 5.10: The contour in Exercise 11f.

(g) $\frac{1}{2\pi i} \oint_{\gamma} f(z) dz$ where $f(z) = \frac{\sin z}{z(z+2i)^3}$ and γ is as in Figure 5.11.

(h) $\frac{1}{2\pi i} \oint_{\gamma} f(z) dz$ where $f(z) = \frac{e^{iz}}{(\sin z)(\cos z)}$ and γ is the positively (counterclockwise) oriented quadrilateral with vertices $\pm 5i, \pm 10$,

(i) $\frac{1}{2\pi i} \oint_{\gamma} f(z) dz$ where $f(z) = \tan z$ and γ is the curve in Figure 5.12.

- 12.** Let $R(z)$ be a rational function: $R(z) = p(z)/q(z)$ where p and q are holomorphic polynomials. Let f be holomorphic on $\mathbb{C} \setminus \{P_1, P_2, \dots, P_k\}$ and suppose that f has a pole at each of the points P_1, P_2, \dots, P_k . Finally assume that

$$|f(z)| \leq |R(z)|$$

for all z at which $f(z)$ and $R(z)$ are defined. Prove that f is a constant multiple of R . In particular, f is rational. [**Hint:** Think about $f(z)/R(z)$.]

- 13.** Let $f : D(P, r) \setminus \{P\} \rightarrow \mathbb{C}$ be holomorphic. Let $U = f(D(P, r) \setminus \{P\})$. Assume that U is open (we shall later see that this is always the case if f is nonconstant). Let $g : U \rightarrow \mathbb{C}$ be holomorphic. If f has a removable

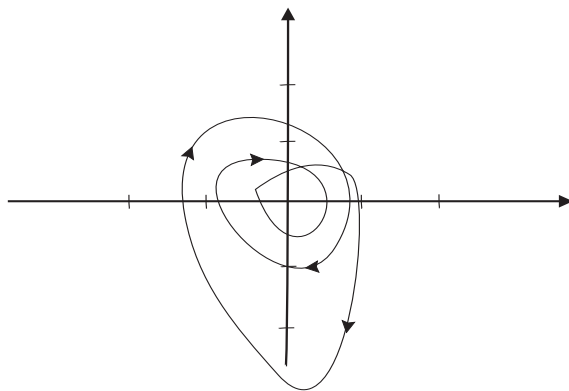


Figure 5.11: The contour in Exercise 11g.

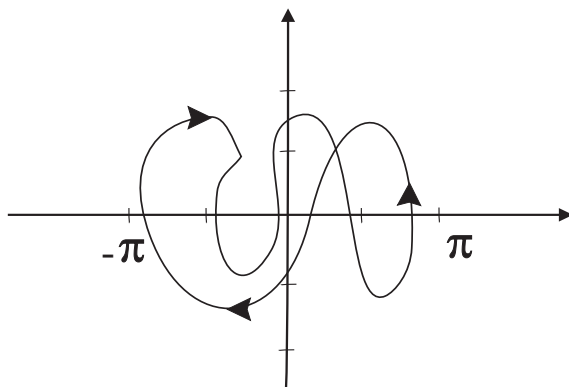


Figure 5.12: The contour in Exercise 11i.

singularity at P , does $g \circ f$ have one also? What about the case of poles and essential singularities?

14. A certain incompressible fluid flow has poles at 0, 1, and i . Each pole is a simple pole, and the respective residues are 3, -5 , and 2. Follow along a counterclockwise path consisting of a square of side 4 with center 0 and sides parallel to the axes. What can you say about the flow along that path?

5.5 Applications to the Calculation of Definite Integrals and Sums

5.5.1 The Evaluation of Definite Integrals

One of the most classical and fascinating applications of the calculus of residues is the calculation of definite (usually improper) real integrals. It is an oversimplification to call these calculations, taken together, a “technique”: it is more like a *collection* of techniques. We present several instances of the method.

5.5.2 A Basic Example

To evaluate

$$\int_{-\infty}^{\infty} \frac{1}{1+x^4} dx, \quad (5.31)$$

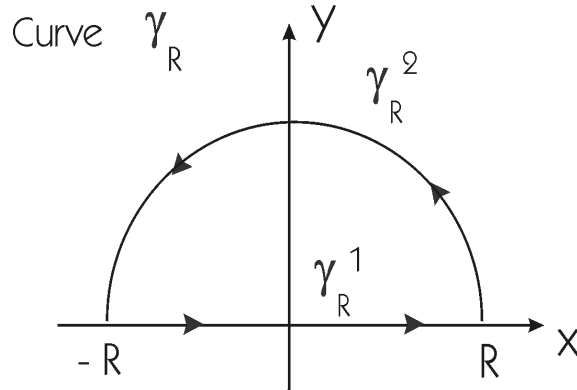
we “complexify” the integrand to $f(z) = 1/(1+z^4)$ and consider the integral

$$\oint_{\gamma_R} \frac{1}{1+z^4} dz. \quad (5.32)$$

See Figure 5.13.

Now part of the game here is to choose the right piecewise C^1 curve or “contour” γ_R . The appropriateness of our choice is justified (after the fact) by the calculation that we are about to do. Assume that $R > 1$. Define

$$\begin{aligned} \gamma_R^1(t) &= t + i0 \quad \text{if} \quad -R \leq t \leq R, \\ \gamma_R^2(t) &= Re^{it} \quad \text{if} \quad 0 \leq t \leq \pi. \end{aligned}$$


 Figure 5.13: The curve γ_R in Section 5.5.2.

Call these two curves, taken together, γ or γ_R .

Now we set $U = \mathbb{C}$, $P_1 = 1/\sqrt{2} + i/\sqrt{2}$, $P_2 = -1/\sqrt{2} + i/\sqrt{2}$, $P_3 = -1/\sqrt{2} - i/\sqrt{2}$, $P_4 = 1/\sqrt{2} - i/\sqrt{2}$; the points P_1, P_2, P_3, P_4 are the poles of $1/[1 + z^4]$. Thus $f(z) = 1/(1 + z^4)$ is holomorphic on $U \setminus \{P_1, \dots, P_4\}$ and the Residue Theorem applies.

On the one hand,

$$\oint_{\gamma} \frac{1}{1 + z^4} dz = 2\pi i \sum_{j=1,2} \text{Ind}_{\gamma}(P_j) \cdot \text{Res}_f(P_j), \quad (5.33)$$

where we sum only over the poles of f that lie inside γ . These are P_1 and P_2 . An easy calculation shows that

$$\text{Res}_f(P_1) = \frac{1}{4(1/\sqrt{2} + i/\sqrt{2})^3} = -\frac{1}{4} \left(\frac{1}{\sqrt{2}} + i\frac{1}{\sqrt{2}} \right) \quad (5.34)$$

and

$$\text{Res}_f(P_2) = \frac{1}{4(-1/\sqrt{2} + i/\sqrt{2})^3} = -\frac{1}{4} \left(-\frac{1}{\sqrt{2}} + i\frac{1}{\sqrt{2}} \right). \quad (5.35)$$

Of course the index at each point is 1. So

$$\begin{aligned} \oint_{\gamma} \frac{1}{1 + z^4} dz &= 2\pi i \left(-\frac{1}{4} \right) \left[\left(\frac{1}{\sqrt{2}} + i\frac{1}{\sqrt{2}} \right) + \left(-\frac{1}{\sqrt{2}} + i\frac{1}{\sqrt{2}} \right) \right] \\ &= \frac{\pi}{\sqrt{2}}. \end{aligned} \quad (5.36)$$

On the other hand,

$$\oint_{\gamma} \frac{1}{1+z^4} dz = \oint_{\gamma_R^1} \frac{1}{1+z^4} dz + \oint_{\gamma_R^2} \frac{1}{1+z^4} dz. \quad (5.37)$$

Trivially,

$$\oint_{\gamma_R^1} \frac{1}{1+z^4} dz = \int_{-R}^R \frac{1}{1+t^4} \cdot 1 \cdot dt \rightarrow \int_{-\infty}^{\infty} \frac{1}{1+t^4} dt \quad (5.38)$$

as $R \rightarrow +\infty$. That is good, because this last is the integral that we wish to evaluate. Better still,

$$\left| \oint_{\gamma_R^2} \frac{1}{1+z^4} dz \right| \leq \{\text{length}(\gamma_R^2)\} \cdot \max_{\gamma_R^2} \left| \frac{1}{1+z^4} \right| \leq \pi R \cdot \frac{1}{R^4-1}. \quad (5.39)$$

[Here we use the inequality $|1+z^4| \geq |z|^4 - 1$, as well as (2.41).] Thus

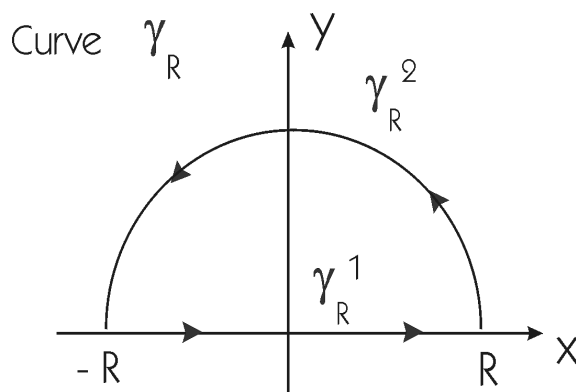
$$\left| \oint_{\gamma_R^2} \frac{1}{1+z^4} dz \right| \rightarrow 0 \quad \text{as} \quad R \rightarrow \infty. \quad (5.40)$$

Finally, (5.36), (5.38), (5.40) taken together yield

$$\begin{aligned} \frac{\pi}{\sqrt{2}} &= \lim_{R \rightarrow \infty} \oint_{\gamma} \frac{1}{1+z^4} dz \\ &= \lim_{R \rightarrow \infty} \oint_{\gamma_R^1} \frac{1}{1+z^4} dz + \lim_{R \rightarrow \infty} \oint_{\gamma_R^2} \frac{1}{1+z^4} dz \\ &= \int_{-\infty}^{\infty} \frac{1}{1+t^4} dt + 0. \end{aligned}$$

This solves the problem: the value of the integral is $\pi/\sqrt{2}$.

In other problems, it will not be so easy to pick the contour so that the superfluous parts (in the above example, this would be the integral over γ_R^2) tend to zero, nor is it always so easy to prove that they *do* tend to zero. Sometimes, it is not even obvious how to complexify the integrand.

Figure 5.14: The curve γ_R in Section 5.5.3.

5.5.3 Complexification of the Integrand

We evaluate

$$\int_{-\infty}^{\infty} \frac{\cos x}{1+x^2} dx \quad (5.41)$$

by using the contour γ_R as in Figure 5.14 (that is, the same contour as in the last example). The obvious choice for the complexification of the integrand is

$$f(z) = \frac{\cos z}{1+z^2} = \frac{[e^{iz} + e^{-iz}]/2}{1+z^2} = \frac{[e^{ix}e^{-y} + e^{-ix}e^y]/2}{1+z^2}. \quad (5.42)$$

Now $|e^{iz}| = |e^{ix}e^{-y}| = |e^{-y}| \leq 1$ on γ_R but $|e^{-iz}| = |e^{-ix}e^y| = |e^y|$ becomes quite large on γ_R when R is large and positive. There is no evident way to alter the contour so that good estimates result. Instead, we alter the function! Let $g(z) = e^{iz}/(1+z^2)$.

Of course the poles of g are at i and $-i$. Of these two, only i lies inside the contour. On the one hand (for $R > 1$),

$$\begin{aligned} \oint_{\gamma_R} g(z) &= 2\pi i \cdot \text{Res}_g(i) \cdot \text{Ind}_{\gamma_R}(i) \\ &= 2\pi i \left(\frac{1}{2ei} \right) \cdot 1 = \frac{\pi}{e}. \end{aligned}$$

On the other hand, with $\gamma_R^1(t) = t$, $-R \leq t \leq R$, and $\gamma_R^2(t) = Re^{it}$, $0 \leq t \leq \pi$,

we have

$$\oint_{\gamma_R} g(z) dz = \oint_{\gamma_R^1} g(z) dz + \oint_{\gamma_R^2} g(z) dz. \quad (5.43)$$

Of course

$$\oint_{\gamma_R^1} g(z) dz \rightarrow \int_{-\infty}^{\infty} \frac{e^{ix}}{1+x^2} dx \quad \text{as } R \rightarrow \infty. \quad (5.44)$$

And

$$\left| \oint_{\gamma_R^2} g(z) dz \right| \leq \text{length}(\gamma_R^2) \cdot \max_{\gamma_R^2} |g| \leq \pi R \cdot \frac{1}{R^2 - 1} \rightarrow 0 \quad \text{as } R \rightarrow \infty. \quad (5.45)$$

Here we have again reasoned as in the last section.

Thus

$$\int_{-\infty}^{\infty} \frac{\cos x}{1+x^2} dx = \text{Re} \int_{-\infty}^{\infty} \frac{e^{ix}}{1+x^2} dx = \text{Re} \left(\frac{\pi}{e} \right) = \frac{\pi}{e}. \quad (5.46)$$

5.5.4 An Example with a More Subtle Choice of Contour

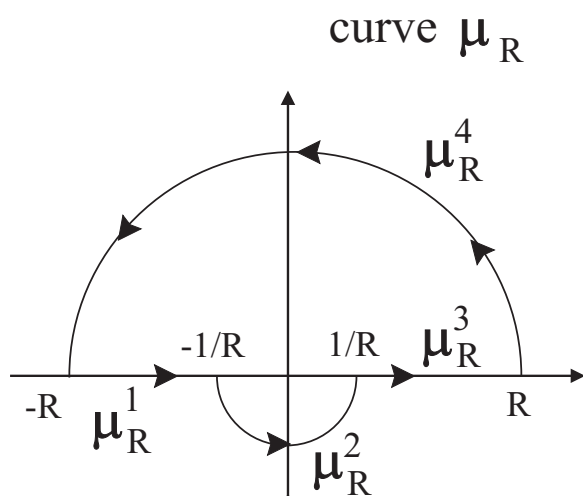
Let us evaluate

$$\int_{-\infty}^{\infty} \frac{\sin x}{x} dx. \quad (5.47)$$

Before we begin, we remark that $\sin x/x$ is bounded near zero; also, the integral converges at ∞ (as an improper Riemann integral) by integration by parts. So the problem makes sense. Using the lesson learned from the last example, we consider the function $g(z) = e^{iz}/z$. However, the pole of e^{iz}/z is at $z = 0$ and that lies *on the contour* in Figure 5.14. Thus *that* contour may not be used. We instead use the contour $\mu = \mu_R$ that is depicted in Figure 5.15.

Define

$$\begin{aligned} \mu_R^1(t) &= t, & -R \leq t \leq -1/R, \\ \mu_R^2(t) &= e^{it}/R, & \pi \leq t \leq 2\pi, \\ \mu_R^3(t) &= t, & 1/R \leq t \leq R, \\ \mu_R^4(t) &= Re^{it}, & 0 \leq t \leq \pi. \end{aligned}$$


 Figure 5.15: The curve μ_R in Section 5.5.4.

Clearly

$$\oint_{\mu} g(z) dz = \sum_{j=1}^4 \oint_{\mu_R^j} g(z) dz. \quad (5.48)$$

On the one hand, for $R > 0$,

$$\oint_{\mu} g(z) dz = 2\pi i \operatorname{Res}_g(0) \cdot \operatorname{Ind}_{\mu}(0) = 2\pi i \cdot 1 \cdot 1 = 2\pi i. \quad (5.49)$$

On the other hand,

$$\int_{\mu_R^1} g(z) dz + \int_{\mu_R^3} g(z) dz \rightarrow \int_{-\infty}^{\infty} \frac{e^{ix}}{x} dx \quad \text{as } R \rightarrow \infty. \quad (5.50)$$

Furthermore,

$$\left| \int_{\mu_R^4} g(z) dz \right| \leq \left| \int_{\operatorname{Im} y < \sqrt{R}}^{\mu_R^4} g(z) dz \right| + \left| \int_{\operatorname{Im} y \geq \sqrt{R}}^{\mu_R^4} g(z) dz \right| \quad (5.51)$$

$$\equiv A + B. \quad (5.52)$$

Now

$$\begin{aligned} A &\leq \text{length}(\mu_R^4 \cap \{z : \text{Im } z < \sqrt{R}\}) \cdot \max\{|g(z)| : z \in \mu_R^4, y < \sqrt{R}\} \\ &\leq 4\sqrt{R} \cdot \left(\frac{1}{R}\right) \rightarrow 0 \quad \text{as } R \rightarrow \infty. \end{aligned}$$

Also

$$\begin{aligned} B &\leq \text{length}(\mu_R^4 \cap \{z : \text{Im } z \geq \sqrt{R}\}) \cdot \max\{|g(z)| : z \in \mu_R^4, y \geq \sqrt{R}\} \\ &\leq \pi R \cdot \left(\frac{e^{-\sqrt{R}}}{R}\right) \rightarrow 0 \quad \text{as } R \rightarrow \infty. \end{aligned}$$

So

$$\left| \oint_{\mu_R^4} g(z) dz \right| \rightarrow 0 \quad \text{as } R \rightarrow \infty. \quad (5.53)$$

Finally,

$$\begin{aligned} \oint_{\mu_R^2} g(z) dz &= \int_{\pi}^{2\pi} \frac{e^{i(e^{it}/R)}}{e^{it}/R} \cdot \left(\frac{i}{R} e^{it}\right) dt \\ &= i \int_{\pi}^{2\pi} e^{i(e^{it}/R)} dt. \end{aligned}$$

As $R \rightarrow \infty$ this tends to

$$\begin{aligned} &= i \int_{\pi}^{2\pi} 1 dt \\ &= \pi i \quad \text{as } R \rightarrow \infty. \end{aligned} \quad (5.54)$$

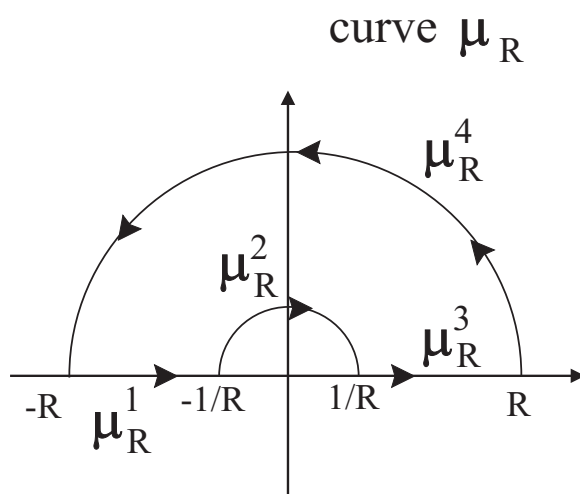
In summary, (5.49) through (5.54) yield

$$2\pi i = \oint_{\mu} g(z) dz = \sum_{n=1}^4 \oint_{\mu_R^n} g(z) dz \quad (5.55)$$

$$\rightarrow \int_{-\infty}^{\infty} \frac{e^{ix}}{x} dx + \pi i \quad \text{as } R \rightarrow \infty. \quad (5.56)$$

Taking imaginary parts yields

$$\pi = \int_{-\infty}^{\infty} \frac{\sin x}{x} dx. \quad (5.57)$$

Figure 5.16: The curve μ_R in Section 5.5.5.

5.5.5 Making the Spurious Part of the Integral Disappear

Consider the integral

$$\int_0^{\infty} \frac{x^{1/3}}{1+x^2} dx. \quad (5.58)$$

We complexify the integrand by setting $f(z) = z^{1/3}/(1+z^2)$. Note that, on the simply connected set $U = \mathbb{C} \setminus \{iy : y < 0\}$, the expression $z^{1/3}$ is unambiguously defined as a holomorphic function by setting $z^{1/3} = r^{1/3}e^{i\theta/3}$ when $z = re^{i\theta}$, $-\pi/2 < \theta < 3\pi/2$. We use the contour displayed in Figure 5.16.

We must do this since $z^{1/3}$ is not a well-defined holomorphic function in any neighborhood of 0. Let us use the notation from the figure. We refer to the preceding examples for some of the parametrizations that we now use.

Clearly

$$\oint_{\mu_R^3} f(z) dz \rightarrow \int_0^{\infty} \frac{t^{1/3}}{1+t^2} dt. \quad (5.59)$$

Of course that is good, but what will become of the integral over μ_R^1 ? We

have

$$\begin{aligned} \oint_{\mu_R^1} &= \int_{-R}^{-1/R} \frac{t^{1/3}}{1+t^2} dt \\ &= \int_{1/R}^R \frac{(-t)^{1/3}}{1+t^2} dt \\ &= \int_{1/R}^R \frac{e^{i\pi/3} t^{1/3}}{1+t^2} dt. \end{aligned}$$

(by our definition of $z^{1/3}$!). Thus

$$\oint_{\mu_R^3} f(z) dz + \oint_{\mu_R^1} f(z) dz \rightarrow \left(1 + \left(\frac{1}{2} + \frac{\sqrt{3}}{2}i\right)\right) \int_0^\infty \frac{t^{1/3}}{1+t^2} dt \quad \text{as } R \rightarrow +\infty. \quad (5.60)$$

On the other hand,

$$\left| \oint_{\mu_R^1} f(z) dz \right| \leq \pi R \cdot \frac{R^{1/3}}{R^2 - 1} \rightarrow 0 \quad \text{as } R \rightarrow +\infty \quad (5.61)$$

and

$$\begin{aligned} \oint_{\mu_R^2} f(z) dz &= \int_{-\pi}^{-2\pi} \frac{(e^{it}/R)^{1/3}}{1 + e^{2it}/R^2} (i) e^{it}/R dt \\ &= R^{-4/3} \int_{-\pi}^{-2\pi} \frac{e^{i4t/3}}{1 + e^{2it}/R^2} dt \rightarrow 0 \quad \text{as } R \rightarrow +\infty. \end{aligned}$$

So, altogether then,

$$\oint_{\mu_R} f(z) dz \rightarrow \left(\frac{3}{2} + \frac{\sqrt{3}}{2}i\right) \int_0^\infty \frac{t^{1/3}}{1+t^2} dt \quad \text{as } R \rightarrow +\infty. \quad (5.62)$$

The calculus of residues tells us that, for $R > 1$,

$$\begin{aligned} \oint_{\mu_R} f(z) dz &= 2\pi i \operatorname{Res}_f(i) \cdot \operatorname{Ind}_{\mu_R}(i) \\ &= 2\pi i \left(\frac{e^{i\pi/6}}{2i}\right) \cdot 1 \\ &= \pi \left(\frac{\sqrt{3}}{2} + \frac{i}{2}\right). \end{aligned} \quad (5.63)$$

Finally, (5.62) and (5.63) taken together yield

$$\int_0^\infty \frac{t^{1/3}}{1+t^2} dt = \frac{\pi}{\sqrt{3}}. \quad \square$$

5.5.6 The Use of the Logarithm

While the integral

$$\int_0^\infty \frac{dx}{x^2 + 6x + 8} \quad (5.64)$$

can be calculated using methods of calculus, it is enlightening to perform the integration by complex variable methods. Note that if we endeavor to use the integrand $f(z) = 1/(z^2 + 6z + 8)$ together with the idea of the last example, then there is no “auxiliary radius” that helps. More precisely, $((re^{i\theta})^2 + 6re^{i\theta} + 8)$ is a constant multiple of $r^2 + 6r + 8$ only if θ is an integer multiple of 2π . The following nonobvious device is often of great utility in problems of this kind. Define $\log z$ on $U \equiv \mathbb{C} \setminus \{x + i0 : x \geq 0\}$ by $\log(re^{i\theta}) = (\log r) + i\theta$ when $0 < \theta < 2\pi, r > 0$. Here $\log r$ is understood to be the standard real logarithm. Then, on U , \log is a well-defined holomorphic function. [Observe here that there are infinitely many ways to define the logarithm function on U . One could set $\log(re^{i\theta}) = (\log r) + i(\theta + 2k\pi)$ for any integer choice of k . What we have done here is called “choosing a branch” of the logarithm. See Section 2.5.]

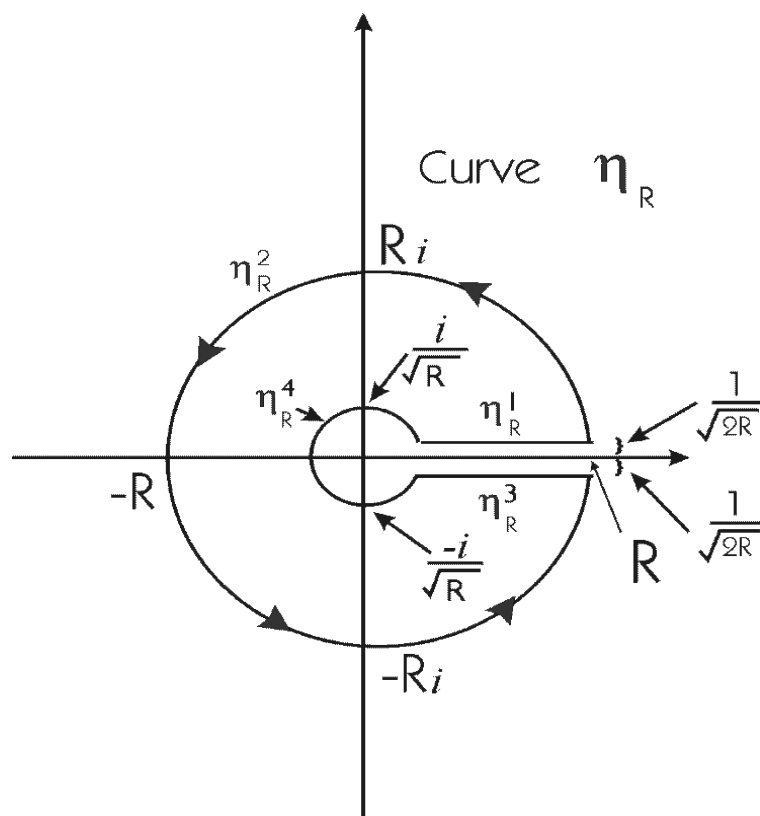
We use the contour η_R displayed in Figure 5.17 and integrate the function $g(z) = \log z/(z^2 + 6z + 8)$. Let

$$\begin{aligned} \eta_R^1(t) &= t + i/\sqrt{2R}, & 1/\sqrt{2R} \leq t \leq R, \\ \eta_R^2(t) &= Re^{it}, & \theta_0 \leq t \leq 2\pi - \theta_0, \end{aligned}$$

where $\theta_0(R) = \tan^{-1}(1/(R\sqrt{2R}))$

$$\begin{aligned} \eta_R^3(t) &= R - t - i/\sqrt{2R}, & 0 \leq t \leq R - 1/\sqrt{2R}, \\ \eta_R^4(t) &= e^{-it}/\sqrt{R}, & \pi/4 \leq t \leq 7\pi/4. \end{aligned}$$

Now

Figure 5.17: The curve μ_R in Section 5.5.6.

$$\begin{aligned}
\oint_{\eta_R} g(z) dz &= 2\pi i (\operatorname{Res}_{\eta_R}(-2) \cdot 1 + \operatorname{Res}_{\eta_R}(-4) \cdot 1) \\
&= 2\pi i \left(\frac{\log(-2)}{2} + \frac{\log(-4)}{-2} \right) \\
&= 2\pi i \left(\frac{\log 2 + \pi i}{2} + \frac{\log 4 + \pi i}{-2} \right) \\
&= -\pi i \log 2.
\end{aligned} \tag{5.65}$$

Also, it is straightforward to check that

$$\left| \oint_{\eta_R^2} g(z) dz \right| \rightarrow 0, \tag{5.66}$$

$$\left| \oint_{\eta_R^4} g(z) dz \right| \rightarrow 0, \tag{5.67}$$

as $R \rightarrow +\infty$. The device that makes this technique work is that, as $R \rightarrow +\infty$,

$$\log(x + i/\sqrt{2R}) - \log(x - i/\sqrt{2R}) \rightarrow -2\pi i. \tag{5.68}$$

So

$$\oint_{\eta_R^1} g(z) dz + \oint_{\eta_R^3} g(z) dz \rightarrow -2\pi i \int_0^\infty \frac{dt}{t^2 + 6t + 8}. \tag{5.69}$$

Now (5.65) through (5.69) taken together yield

$$\int_0^\infty \frac{dt}{t^2 + 6t + 8} = \frac{1}{2} \log 2. \tag{5.70}$$

5.5.7 Summary Chart of Some Integration Techniques

In what follows we present, in chart form, just a few of the key methods of using residues to evaluate definite integrals.

Use of Residues to Evaluate Integrals

Integral	Properties of	Value of Integral
$I = \int_{-\infty}^{\infty} f(x) dx$	No poles of $f(z)$ on real axis. Finite number of poles of $f(z)$ in plane. $ f(z) \leq \frac{C}{ z ^2}$ for z large.	$I = 2\pi i \times$ $\left(\begin{array}{c} \text{sum of residues} \\ \text{of } f \text{ in upper} \\ \text{half-plane} \end{array} \right)$
$I = \int_{-\infty}^{\infty} f(x) dx$	$f(z)$ may have simple poles on real axis. Finite number of poles of $f(z)$ in plane. $ f(z) \leq \frac{C}{ z ^2}$ for z large.	$I = 2\pi i \times$ $\left(\begin{array}{c} \text{sum of residues} \\ \text{of } f \text{ in upper} \\ \text{half-plane} \end{array} \right)$ $+ \pi i \times$ $\left(\begin{array}{c} \text{sum of residues} \\ \text{of } f(z) \\ \text{on real axis} \end{array} \right)$
$I = \int_{-\infty}^{\infty} \frac{p(x)}{q(x)} dx$	p, q polynomials. $[\deg p] + 2 \leq \deg q$. q has no real zeros.	$I = 2\pi i \times$ $\left(\begin{array}{c} \text{sum of residues} \\ \text{of } p(z)/q(z) \\ \text{in upper half} \\ \text{plane} \end{array} \right)$

Use of Residues to Evaluate Integrals, Continued

Integral	Properties of	Value of Integral
$I = \int_{-\infty}^{\infty} \frac{p(x)}{q(x)} dx$	<p>p, q polynomials. $[\deg p] + 2 \leq \deg q$. $p(z)/q(z)$ may have simple poles on real axis.</p>	$I = 2\pi i \times \left(\begin{array}{l} \text{sum of residues} \\ \text{of } p(z)/q(z) \\ \text{in upper half} \\ \text{plane} \end{array} \right) + \pi i \times \left(\begin{array}{l} \text{sum of residues} \\ \text{of } p(z)/q(z) \\ \text{on real axis} \end{array} \right)$
$I = \int_{-\infty}^{\infty} e^{i\alpha x} \cdot f(x) dx$	<p>$\alpha > 0, z$ large $f(z) \leq \frac{C}{ z }$ No poles of f on real axis.</p>	$I = 2\pi i \times \left(\begin{array}{l} \text{sum of residues} \\ \text{of } e^{i\alpha z} f(z) \\ \text{in upper half} \\ \text{plane} \end{array} \right)$
$I = \int_{-\infty}^{\infty} e^{i\alpha x} \cdot f(x) dx$	<p>$\alpha > 0, z$ large $f(z) \leq \frac{C}{ z }$ $f(z)$ may have simple poles on real axis</p>	$I = 2\pi i \times \left(\begin{array}{l} \text{sum of residues} \\ \text{of } e^{i\alpha z} f(z) \\ \text{in upper half} \\ \text{plane} \end{array} \right) + \pi i \times \left(\begin{array}{l} \text{sum of residues} \\ \text{of } e^{i\alpha z} f(z) \\ \text{on real axis} \end{array} \right)$

Exercises

Use the calculus of residues to calculate the integrals in Exercises 1 through 13:

1. $\int_0^{+\infty} \frac{1}{1+x^4} dx$
2. $\int_{-\infty}^{+\infty} \frac{\cos x}{1+x^4} dx$
3. $\int_0^{+\infty} \frac{x^{1/3}}{1+x^2} dx$
4. $\int_0^{+\infty} \frac{1}{x^3+x+1} dx$
5. $\int_0^{+\infty} \frac{1}{1+x^3} dx$
6. $\int_0^{+\infty} \frac{x \sin x}{1+x^2} dx$
7. $\int_{-\infty}^{\infty} \frac{x^2}{1+x^4} dx$
8. $\int_{-\infty}^{+\infty} \frac{x}{\sinh x} dx$
9. $\int_{-\infty}^{+\infty} \frac{x^2}{1+x^6} dx$
10. $\int_{-\infty}^{\infty} \frac{x^{1/3}}{-1+x^5} dx$
11. $\int_{-\infty}^{+\infty} \frac{\sin^2 x}{x^2} dx$
12. Interpret the first two examples in this section in terms of incompressible fluid flow.

5.6 Meromorphic Functions and Singularities at Infinity

5.6.1 Meromorphic Functions

We have considered carefully those functions that are holomorphic on sets of the form $D(P, r) \setminus \{P\}$ or, more generally, of the form $U \setminus \{P\}$, where U is an open set in \mathbb{C} and $P \in U$. As we have seen in our discussion of the calculus of residues, sometimes it is important to consider the possibility that a function could be “singular” at more than just one point. The appropriate precise definition requires a little preliminary consideration of what kinds of sets might be appropriate as “sets of singularities.”

5.6.2 Discrete Sets and Isolated Points

We review the concept of discrete. A set S in \mathbb{C} is *discrete* if and only if for each $z \in S$ there is a positive number r (depending on z) such that

$$S \cap D(z, r) = \{z\}. \quad (5.71)$$

We also say in this circumstance that S consists of isolated points.

5.6.3 Definition of a Meromorphic Function

Now fix an open set U ; we next define the central concept of meromorphic function on U .

A *meromorphic function* f on U with *singular set* S is a function $f : U \setminus S \rightarrow \mathbb{C}$ such that

(5.72) S is discrete;

(5.73) f is holomorphic on $U \setminus S$ (note that $U \setminus S$ is necessarily open in \mathbb{C});

(5.74) for each $P \in S$ and $r > 0$ such that $D(P, r) \subseteq U$ and $S \cap D(P, r) = \{P\}$, the function $f|_{D(P, r) \setminus \{P\}}$ has a (finite order) pole at P .

For convenience, one often suppresses explicit consideration of the set S and just says that f is a meromorphic function on U . Sometimes we say, informally, that a meromorphic function on U is a function on U that is

holomorphic “except for poles.” Implicit in this description is the idea that a pole is an “isolated singularity.” In other words, a point P is a pole of f if and only if there is a disc $D(P, r)$ around P such that f is holomorphic on $D(P, r) \setminus \{P\}$ and has a pole at P . Back on the level of precise language, we see that our definition of a meromorphic function on U implies that, for each $P \in U$, either there is a disc $D(P, r) \subseteq U$ such that f is holomorphic on $D(P, r)$ or there is a disc $D(P, r) \subseteq U$ such that f is holomorphic on $D(P, r) \setminus \{P\}$ and has a pole at P .

5.6.4 Examples of Meromorphic Functions

Meromorphic functions are very natural objects to consider, primarily because they result from considering the (algebraic) reciprocals of holomorphic functions:

If U is a connected open set in \mathbb{C} and if $f : U \rightarrow \mathbb{C}$ is a holomorphic function with $f \not\equiv 0$, then the function

$$F : U \setminus \{z : f(z) = 0\} \rightarrow \mathbb{C} \tag{5.75}$$

defined by $F(z) = 1/f(z)$ is a meromorphic function on U with singular set (or pole set) equal to $\{z \in U : f(z) = 0\}$. In a sense that can be made precise, all meromorphic functions arise as *quotients* of holomorphic functions.

5.6.5 Meromorphic Functions with Infinitely Many Poles

It is quite possible for a meromorphic function on an open set U to have infinitely many poles in U . The function $1/\sin(1/(1-z))$ is an obvious example on $U = D$. Notice, however, that the poles do not accumulate anywhere in D .

5.6.6 Singularities at Infinity

Our discussion so far of singularities of holomorphic functions can be generalized to include the limit behavior of holomorphic functions as $|z| \rightarrow +\infty$. This is a powerful method with many important consequences. Suppose for example that $f : \mathbb{C} \rightarrow \mathbb{C}$ is an entire function. We can associate to f a new function $G : \mathbb{C} \setminus \{0\} \rightarrow \mathbb{C}$ by setting $G(z) = f(1/z)$. The behavior

of the function G near 0 reflects, in an obvious sense, the behavior of f as $|z| \rightarrow +\infty$. For instance

$$\lim_{|z| \rightarrow +\infty} |f(z)| = +\infty \quad (5.76)$$

if and only if G has a pole at 0.

Suppose that $f : U \rightarrow \mathbb{C}$ is a holomorphic function on an open set $U \subseteq \mathbb{C}$ and that, for some $R > 0$, $U \supseteq \{z : |z| > R\}$. Define $G : \{z : 0 < |z| < 1/R\} \rightarrow \mathbb{C}$ by $G(z) = f(1/z)$. Then we say that

(5.77) f has a *removable singularity* at ∞ if G has a removable singularity at 0.

(5.78) f has a *pole* at ∞ if G has a pole at 0.

(5.79) f has an *essential singularity* at ∞ if G has an essential singularity at 0.

5.6.7 The Laurent Expansion at Infinity

The Laurent expansion of G around 0, $G(z) = \sum_{-\infty}^{+\infty} a_j z^j$, yields immediately a series expansion for f which converges for $|z| > R$, namely,

$$f(z) \equiv G(1/z) = \sum_{-\infty}^{+\infty} a_j z^{-j} = \sum_{-\infty}^{+\infty} a_{-j} z^j. \quad (5.80)$$

The series $\sum_{-\infty}^{+\infty} a_{-n} z^n$ is called the *Laurent expansion of f around ∞* . It follows from our definitions and from our earlier discussions that f has a removable singularity at ∞ if and only if the Laurent series of f at ∞ has no *positive* powers of z with nonzero coefficients. Also f has a pole at ∞ if and only if the series has only a finite number of positive powers of z with nonzero coefficients. Finally, f has an essential singularity at ∞ if and only if the series has infinitely many positive powers.

5.6.8 Meromorphic at Infinity

Let f be an entire function with a removable singularity at infinity. This means, in particular, that f is bounded near infinity. But then f is a bounded, entire function so it is constant.

Now suppose that f is entire and has a pole at infinity. Then $G(z) = f(1/z)$ has a pole (of some order k) at the origin. Hence $z^k G(z)$ has a removable singularity at the origin. We conclude then that $z^{-k} \cdot f(z)$ has a removable singularity at ∞ .

Thus $z^{-k} \cdot f(z)$ is bounded near infinity. Certainly f is bounded on any compact subset of the plane. All told, then,

$$|f(z)| \leq C(1 + |z|)^k.$$

Now examine the Cauchy estimates at the origin, on a disc $D(0, R)$, for the $(k + 1)^{\text{st}}$ derivative of f . We find that

$$\left| \frac{\partial^{k+1}}{\partial z^{k+1}} f(0) \right| \leq \frac{(k+1)! C(1+R)^k}{R^{k+1}}.$$

As $R \rightarrow +\infty$ we find that the $(k + 1)^{\text{st}}$ derivative of f at 0 is 0. In fact the same estimate can be proved at any point P in the plane. We conclude that $f^{(k+1)} \equiv 0$. Thus f must be a polynomial of degree at most k .

We have treated the cases of an entire function f having a removable singularity or a pole at infinity. The only remaining possibility is an essential singularity at infinity. The function $f(z) = e^z$ is an example of such a function. Any transcendental entire function has an essential singularity at infinity.

Suppose that f is a meromorphic function defined on an open set $U \subseteq \mathbb{C}$ such that, for some $R > 0$, we have $U \supseteq \{z : |z| > R\}$. We say that f is *meromorphic* at ∞ if the function $G(z) \equiv f(1/z)$ is meromorphic in the usual sense on $\{z : |z| < 1/R\}$.

5.6.9 Meromorphic Functions in the Extended Plane

The definition of “meromorphic at ∞ ” as given is equivalent to requiring that, for some $R' > R$, f has no poles in $\{z \in \mathbb{C} : R' < |z| < \infty\}$ and that f has a pole at ∞ .

A meromorphic function f on \mathbb{C} which is also meromorphic at ∞ must be a rational function (that is, a quotient of polynomials in z). Conversely, every rational function is meromorphic on \mathbb{C} and at ∞ .

Remark: It is conventional to rephrase the ideas just presented by saying that the only functions that are meromorphic in the “extended plane” are rational functions. We will say more about the extended plane in Sections 7.3.1 through 7.3.3.

Exercises

1. A holomorphic function f on a set of the form $\{z : |z| > R\}$, some $R > 0$, is said to have a zero at ∞ of order k if $f(1/z)$ has a zero of order k at 0. Using this definition as motivation, give a definition of *pole* of order k at ∞ . If g has a pole of order k at ∞ , what property does $1/g$ have at ∞ ? What property does $1/g(1/z)$ have at 0?

2. This exercise develops a notion of residue at ∞ .

First, note that if f is holomorphic on a set $D(0, r) \setminus \{0\}$ and if $0 < s < r$, then “the residue at 0” $= \frac{1}{2\pi i} \oint_{\partial D(0,s)} g(z) dz$ picks out one particular coefficient of the Laurent expansion of f about 0, namely it equals a_{-1} . If g is defined and holomorphic on $\{z : |z| > R\}$, then the residue at ∞ of g is defined to be the negative of the residue at 0 of $H(z) = z^{-2} \cdot g(1/z)$ (Because a positively oriented circle about ∞ is negatively oriented with respect to the origin and vice versa, we defined the *residue of g* at ∞ to be the *negative* of the residue of H at 0.) Prove that the residue at ∞ of g is the coefficient of z in the Laurent expansion of g on $\{z : |z| > R\}$. Prove also that the definition of residue of g at ∞ remains unchanged if the origin is replaced by some other point in the finite plane.

3. Refer to Exercise 2 for terminology. Let $R(z)$ be a rational function (quotient of polynomials). Prove that the sum of all the residues (including the residue at ∞) of R is zero. Is this true for a more general class of functions than rational functions?
4. Refer to Exercise 2 for terminology. Calculate the residue of the given function at ∞ .

(a) $f(z) = z^3 - 7z^2 + 8$

(b) $f(z) = z^2 e^z$

(c) $f(z) = (z + 5)^2 e^z$

(d) $f(z) = p(z)e^z$, for p a polynomial

(e) $f(z) = \frac{p(z)}{q(z)}$, where p and q are polynomials

(f) $f(z) = \sin z$

(g) $f(z) = \cot z$

(h) $f(z) = \frac{e^z}{p(z)}$, where p is a polynomial

5. Give an example of a nontrivial holomorphic function on the upper half-plane that has infinitely many poles.
6. Give an example of an incompressible fluid flow with two poles of order 1. Consider the case where the residues add to zero, and the case where they do not add to zero. How do these situations differ in physical terms?
7. Let f be a meromorphic function on a region $U \subseteq \mathbb{C}$. Prove that the set of poles of f cannot have an interior accumulation point. [**Hint:** Consider the function $g = 1/f$. If the pole set of f has an interior accumulation point then the zero set of g has an interior accumulation point.]

Chapter 6

The Argument Principle

6.1 Counting Zeros and Poles

6.1.1 Local Geometric Behavior of a Holomorphic Function

In this chapter, we shall be concerned with questions that have a geometric, qualitative nature rather than an analytical, quantitative one. These questions center around the issue of the local geometric behavior of a holomorphic function.

6.1.2 Locating the Zeros of a Holomorphic Function

Suppose that $f : U \rightarrow \mathbb{C}$ is a holomorphic function on a connected, open set $U \subseteq \mathbb{C}$ and that $\overline{D}(P, r) \subseteq U$. We know from the Cauchy integral formula that the values of f on $D(P, r)$ are completely determined by the values of f on $\partial D(P, r)$. In particular, the number and even the location of the zeros of f in $D(P, r)$ are determined in principle by f on $\partial D(P, r)$. But it is nonetheless a pleasant surprise that there is a *simple formula* for the number of zeros of f in $D(P, r)$ in terms of f (and f') on $\partial D(P, r)$. In order to obtain a precise formula, we shall have to agree to count zeros according to multiplicity (see Section 4.1.4). We now explain the precise idea.

Let $f : U \rightarrow \mathbb{C}$ be holomorphic as before, and assume that f has *some* zeros in U but that f is not identically zero. Fix $z_0 \in U$ such that $f(z_0) = 0$. Since the zeros of f are isolated, there is an $r > 0$ such that $\overline{D}(z_0, r) \subseteq U$ and such that f does not vanish on $\overline{D}(z_0, r) \setminus \{z_0\}$.

Now the power series expansion of f about z_0 has a first nonzero term determined by the least positive integer n such that $f^{(n)}(z_0) \neq 0$. (Note that $n \geq 1$ since $f(z_0) = 0$ by hypothesis.) Thus the power series expansion of f about z_0 *begins* with the n th term:

$$f(z) = \sum_{j=n}^{\infty} \frac{1}{j!} \frac{\partial^j f}{\partial z^j}(z_0)(z - z_0)^j. \quad (6.1)$$

Under these circumstances we say that f has a zero of *order* n (or *multiplicity* n) at z_0 . When $n = 1$, then we also say that z_0 is a *simple* zero of f .

The important point to see here is that, near z_0 ,

$$\frac{f'(z)}{f(z)} \approx \frac{[n/n!] \cdot (\partial^n f / \partial z^n)(z_0)(z - z_0)^{n-1}}{[1/n!] \cdot (\partial^n f / \partial z^n)(z_0)(z - z_0)^n} = \frac{n}{z - z_0}.$$

It follows then that

$$\frac{1}{2\pi i} \oint_{\partial D(z_0, r)} \frac{f'(z)}{f(z)} dz \approx \frac{1}{2\pi i} \oint_{\partial D(z_0, r)} \frac{n}{z - z_0} dz = n.$$

On the one hand, this is an approximation. On the other hand, the approximation becomes more and more accurate as r shrinks to 0. And the value of the integral—which is a fixed integer!—is independent of r . Thus we may conclude that we have equality. We repeat that the value of the integral is an *integer*.

In short, the complex line integral of f'/f around the boundary of the disc gives the order of the zero at the center. If there are several zeros of f inside the disc $D(z_0, r)$ then we may break the complex line integral up into individual integrals around each of the zeros (see Figure 6.1), so we have the more general result that the integral of f'/f counts *all* the zeros inside the disc, together with their multiplicities. We shall consider this idea further in the discussion that follows.

6.1.3 Zero of Order n

The concept of zero of “order n ,” or “multiplicity n ,” for a function f is so important that a variety of terminology has grown up around it (see also Section 4.1.4). It has already been noted that, when the multiplicity $n = 1$, then the zero is sometimes called *simple*. For arbitrary n , we sometimes say

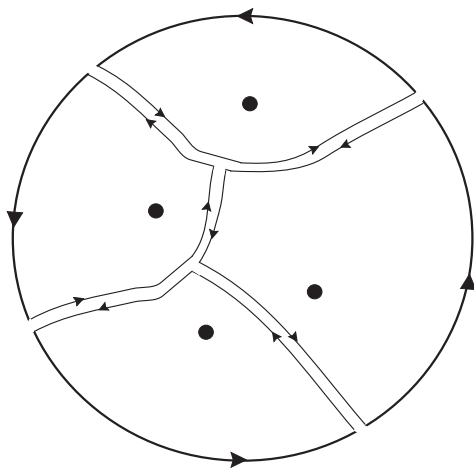


Figure 6.1: Dividing up the complex line integral to count the zeros.

that “ n is the order of z_0 as a zero of f ” or “ f has a zero of order n at z_0 .” More generally, if $f(z_0) = \beta$ in such a way that, for some $n \geq 1$, the function $f(\cdot) - \beta$ has a zero of order n at z_0 , then we say either that “ f assumes the value β at z_0 to order n ” or that “the order of the value β at z_0 is n .” When $n > 1$, then we call z_0 a *multiple point* of the function f and we call β a *multiple value*.

EXAMPLE 48 The function $f(z) = (z - 3)^4$ has a zero of order 4 at the point $z_0 = 3$. This is evident by inspection, because the power series for f about the point $z_0 = 3$ begins with the fourth-order term. But we may also note that $f(3) = 0$, $f'(3) = 0$, $f''(3) = 0$, $f'''(3) = 0$ while $f^{(iv)}(3) = 4! \neq 0$. According to our definition, then, f has a zero of order 4 at $z_0 = 3$.

The function $g(z) = 7 + (z - 5)^3$ takes the value 7 at the point $z_0 = 5$ with multiplicity 3. This is so because $g(z) - 7 = (z - 5)^3$ vanishes to order 3 at the point $z_0 = 5$. \square

The next result summarizes our preceding discussion. It provides a method for computing the multiplicity n of the zero at z_0 from the values of f, f' on the boundary of a disc centered at z_0 .

6.1.4 Counting the Zeros of a Holomorphic Function

THEOREM 3 *If f is holomorphic on a neighborhood of a disc $\overline{D}(P, r)$ and has a zero of order n at P and no other zeros in the closed disc, then*

$$\frac{1}{2\pi i} \oint_{\partial D(P, r)} \frac{f'(\zeta)}{f(\zeta)} d\zeta = n. \quad (6.2)$$

More generally, we consider the case that f has several zeros—with different locations and different multiplicities—inside a disc: Suppose that $f : U \rightarrow \mathbb{C}$ is holomorphic on an open set $U \subseteq \mathbb{C}$ and that $\overline{D}(P, r) \subseteq U$. Suppose further that f is nonvanishing on $\partial D(P, r)$ and that z_1, z_2, \dots, z_k are the zeros of f in the interior of the disc. Let n_ℓ be the order of the zero of f at z_ℓ , $\ell = 1, \dots, k$. Then

$$\frac{1}{2\pi i} \oint_{|\zeta - P| = r} \frac{f'(\zeta)}{f(\zeta)} d\zeta = \sum_{\ell=1}^k n_\ell. \quad (6.3)$$

Refer to Figure 6.2 for illustrations of both these situations.

It is worth noting that the particular features of a *circle* play no special role in these considerations. We could as well consider the zeros of a function f that lie inside a simple, closed curve γ . Then it still holds that

$$(\text{number of zeros inside } \gamma, \text{ counting multiplicity}) = \frac{1}{2\pi i} \oint_{\gamma} \frac{f'(z)}{f(z)} dz. \quad (6.4)$$

EXAMPLE 49 Use the idea of formula (6.4) to calculate the number of zeros of the function $f(z) = z^2 + z$ inside the disc $D(0, 2)$. \square

Solution: Of course we may see by inspection that the function f has precisely two zeros inside the disc (and no zeros on the boundary of the disc). But the point of the exercise is to get some practice with formula (6.4).

We calculate

$$\begin{aligned} \frac{1}{2\pi i} \oint_{\partial D(0, 2)} \frac{f'(z)}{f(z)} dz &= \frac{1}{2\pi i} \oint_{\partial D(0, 2)} \frac{2z + 1}{z^2 + z} dz \\ &= \frac{1}{2\pi i} \oint_{\partial D(0, 2)} \frac{2}{z + 1} dz + \frac{1}{2\pi i} \oint_{\partial D(0, 2)} \frac{1}{z(z + 1)} dz. \end{aligned}$$

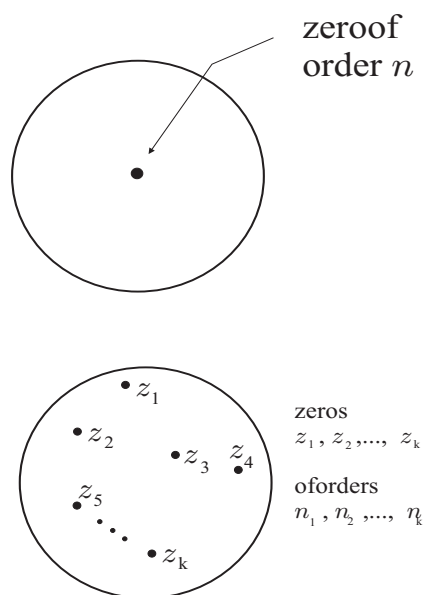


Figure 6.2: Locating the zeros of a holomorphic function.

Now the first integral is a simple Cauchy integral of the function $\phi(z) \equiv 2$, evaluating it at the point $z = -1$. This gives the value 2. The second integral is a double Cauchy integral; here we are integrating the function $\psi(z) \equiv 1/(z + 1)$ and evaluating it at the point 0 and then integrating the function $1/z$ and evaluating it at the point -1 . The result is $1 - 1 = 0$. Altogether then, the value of our original Cauchy integral is $2 + 0 = 2$. And, indeed, that is the number of zeros of the function f inside the disc $D(0, 2)$. \square

Exercise for the Reader: Use formula (6.4) to determine the number of zeros of the function $g(z) = \cos z$ inside the disc $D(0, 4)$.

6.1.5 The Idea of the Argument Principle

This last formula, which is often called the *argument principle*, is both useful and important. For one thing, there is no obvious reason why the integral in the formula should be an integer, much less the crucial integer that it is. Since it is an integer, it is a counting function; and we need to learn more about it.

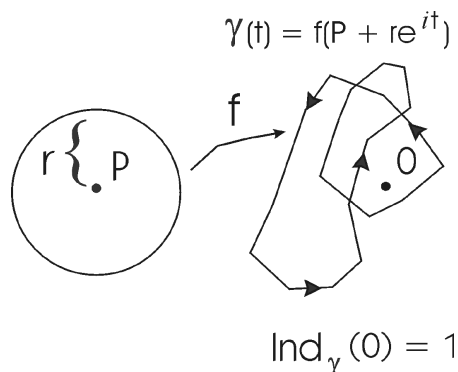


Figure 6.3: The argument principle: counting the zeros.

The integral

$$\frac{1}{2\pi i} \oint_{|\zeta - P| = r} \frac{f'(\zeta)}{f(\zeta)} d\zeta \quad (6.5)$$

can be reinterpreted as follows: Consider the C^1 closed curve

$$\gamma(t) = f(P + re^{it}), \quad t \in [0, 2\pi]. \quad (6.6)$$

Then

$$\frac{1}{2\pi i} \oint_{|\zeta - P| = r} \frac{f'(\zeta)}{f(\zeta)} d\zeta = \frac{1}{2\pi i} \int_0^{2\pi} \frac{\gamma'(t)}{\gamma(t)} dt, \quad (6.7)$$

as you can check by direct calculation. The expression on the right is just the index of the curve γ with respect to 0 (with the notion of index that we defined earlier—Section 5.4.5). See Figure 6.3. Thus the number of zeros of f (counting multiplicity) inside the circle $\{\zeta : |\zeta - P| = r\}$ is equal to the index of γ with respect to the origin. This, intuitively speaking, is equal to the number of times that the f -image of the boundary circle winds around 0 in \mathbb{C} . So we have another way of seeing that the value of the integral must be an integer.

The argument principle can be extended to yield information about meromorphic functions, too. We can see that there is hope for this notion by investigating the analog of the argument principle for a pole.

6.1.6 Location of Poles

If $f : U \setminus \{Q\} \rightarrow \mathbb{C}$ is a nowhere-zero holomorphic function on $U \setminus \{Q\}$ with a pole of order n at Q and if $\overline{D}(Q, r) \subseteq U$, then

$$\frac{1}{2\pi i} \oint_{\partial D(Q, r)} \frac{f'(\zeta)}{f(\zeta)} d\zeta = -n. \quad (6.8)$$

The argument is just the same as the calculations we did right after formula (6.1). [Or else think about the fact that if f has a pole of order n at Q then $1/f$ has a zero of order n at Q . In fact notice that $(1/f)'/(1/f) = -f'/f$. That accounts for the minus sign that arises for a pole.] We shall not repeat the details, but we invite the reader to do so.

6.1.7 The Argument Principle for Meromorphic Functions

Just as with the argument principle for holomorphic functions, this new argument principle gives a counting principle for zeros and poles of meromorphic functions:

Suppose that f is a meromorphic function on an open set $U \subseteq \mathbb{C}$, that $\overline{D}(P, r) \subseteq U$, and that f has neither poles nor zeros on $\partial D(P, r)$. Then

$$\frac{1}{2\pi i} \oint_{\partial D(P, r)} \frac{f'(\zeta)}{f(\zeta)} d\zeta = \sum_{n=1}^p n_n - \sum_{k=1}^q m_k, \quad (6.9)$$

where n_1, n_2, \dots, n_p are the multiplicities of the zeros z_1, z_2, \dots, z_p of f in $D(P, r)$ and m_1, m_2, \dots, m_q are the multiplicities of the poles w_1, w_2, \dots, w_q of f in $D(P, r)$.

Of course the reasoning here is by now familiar. We can break up the complex line integral around the boundary of the disc $D(P, r)$ into integrals around smaller regions, each of which contains just one zero or one pole and no other. Refer again to Figure 6.1. Thus the integral around the disc just sums up $+r$ for each zero of order r and $-s$ for each pole of order s .

Exercises

1. Use the argument principle to give another proof of the Fundamental Theorem of Algebra. [**Hint:** Think about the integral of $p'(z)/p(z)$ over circles centered at the origin of larger and larger radius.]

2. Suppose that f is holomorphic and has n zeros, counting multiplicities, inside U . Can you conclude that f' has $(n - 1)$ zeros inside U ? Can you conclude anything about the zeros of f' ?
3. **Prove:** If f is a polynomial on \mathbb{C} , then the zeros of f' are contained in the closed convex hull of the zeros of f . (Here the *closed convex hull* of a set S is the intersection of all closed convex sets that contain S .)
[**Hint:** If the zeros of f are contained in a half-plane V , then so are the zeros of f' .]
4. Let $P_t(z)$ be a polynomial in z for each fixed value of $t, 0 \leq t \leq 1$. Suppose that $P_t(z)$ is continuous in t in the sense that

$$P_t(z) = \sum_{n=0}^N a_n(t)z^n$$

and each $a_n(t)$ is continuous. Let $\mathcal{Z} = \{(z, t) : P_t(z) = 0\}$. By continuity, \mathcal{Z} is closed in $\mathbb{C} \times [0, 1]$. If $P_{t_0}(z_0) = 0$ and $(\partial/\partial z) P_{t_0}(z) \Big|_{z=z_0} \neq 0$, then show, using the argument principle, that there is an $\epsilon > 0$ such that for t sufficiently near t_0 there is a unique $z \in D(z_0, \epsilon)$ with $P_t(z) = 0$. What can you say if $P_{t_0}(\cdot)$ vanishes to order k at z_0 ?

5. Prove that if $f : U \rightarrow \mathbb{C}$ is holomorphic, $P \in U$, and $f'(P) = 0$, then f is not one-to-one in any neighborhood of P .
6. **Prove:** If f is holomorphic on a neighborhood of the closed unit disc D and if f is one-to-one on ∂D , then f is one-to-one on \overline{D} . [Note: Here you may assume any topological notions you need that seem intuitively plausible. Remark on each one as you use it.]
7. Let $p_t(z) = a_0(t) + a_1(t)z + \cdots + a_n(t)z^n$ be a polynomial in which the coefficients depend continuously on a parameter $t \in (-1, 1)$. Prove that if the roots of p_{t_0} are distinct (no multiple roots), for some fixed value of the parameter, then the same is true for p_t when t is sufficiently close to t_0 —provided that the degree of p_t remains the same as the degree of p_{t_0} .
8. Imitate the proof of the argument principle to prove the following formula: If $f : U \rightarrow \mathbb{C}$ is holomorphic in U and invertible as a function,

$P \in U$, and if $D(P, r)$ is a sufficiently small disc about P , then

$$f^{-1}(w) = \frac{1}{2\pi i} \oint_{\partial D(P, r)} \frac{\zeta f'(\zeta)}{f(\zeta) - w} d\zeta$$

for all w in some disc $D(f(P), r_1)$, $r_1 > 0$ sufficiently small. Derive from this the formula

$$(f^{-1})'(w) = \frac{1}{2\pi i} \oint_{\partial D(P, r)} \frac{\zeta f'(\zeta)}{(f(\zeta) - w)^2} d\zeta.$$

Set $Q = f(P)$. Integrate by parts and use some algebra to obtain

$$(f^{-1})'(w) = \frac{1}{2\pi i} \oint_{\partial D(P, r)} \left(\frac{1}{f(\zeta) - Q} \right) \cdot \left(1 - \frac{w - Q}{f(\zeta) - Q} \right)^{-1} d\zeta. \quad (6.10)$$

Let a_k be the k^{th} coefficient of the power series expansion of f^{-1} about the point Q :

$$f^{-1}(w) = \sum_{k=0}^{\infty} a_k (w - Q)^k.$$

Then formula (6.10) may be expanded and integrated term by term (prove this!) to obtain

$$\begin{aligned} na_n &= \frac{1}{2\pi i} \oint_{\partial D(P, r)} \frac{1}{[f(\zeta) - Q]^n} d\zeta \\ &= \frac{1}{(n-1)!} \left(\frac{\partial}{\partial \zeta} \right)^{n-1} \frac{(\zeta - P)^n}{[f(\zeta) - Q]^n} \Big|_{\zeta=P}. \end{aligned}$$

This is called *Lagrange's formula*.

9. Write a **MatLab** routine to calculate the winding number of any given closed curve about a point not on that curve. What can you do to guarantee that your answer will be an integer? [**Hint:** Think about roundoff error.]
10. Let $D(P, r)$ be a disc in the complex plane and let $p(z)$ be a polynomial. Assume that p has no zeros on the boundary of the disc. Write a **MatLab** routine to calculate the complex line integral that will give the number of zeros of p inside the disc.

11. With reference to the last exercise, suppose that $m(z)$ is a quotient of polynomials. Write a **MatLab** routine that will calculate the number of zeros (counting multiplicity) less the number of poles (counting multiplicity).
12. Give a physical interpretation of the argument principle for an incompressible fluid flow. What does a vanishing point of the flow mean? Why should it be true that the vanishing points (together with their multiplicities) can be detected by the behavior of the flow on the boundary of a disc containing the vanishing points?

6.2 The Local Geometry of Holomorphic Functions

6.2.1 The Open Mapping Theorem

The argument principle for holomorphic functions has a consequence that is one of the most important facts about holomorphic functions considered as geometric mappings:

THEOREM 4 *If $f : U \rightarrow \mathbb{C}$ is a nonconstant holomorphic function on a connected open set U , then $f(U)$ is an open set in \mathbb{C} .*

See Figure 6.4. The result says, in particular, that if $U \subseteq \mathbb{C}$ is connected and open and if $f : U \rightarrow \mathbb{C}$ is holomorphic, then either $f(U)$ is a connected open set (the nonconstant case) or $f(U)$ is a single point.

The open mapping principle has some interesting and important consequences. Among them are:

- (a) If U is a domain in \mathbb{C} and $f : U \rightarrow \mathbb{R}$ is a holomorphic function then f must be constant. For the theorem says that the image of f must be *open* (as a subset of the plane), and the real line contains no planar open sets.
- (b) Let U be a domain in \mathbb{C} and $f : U \rightarrow \mathbb{C}$ a holomorphic function. Suppose that the set E lies in the image of f . Then the image of f must in fact contain a neighborhood of E .

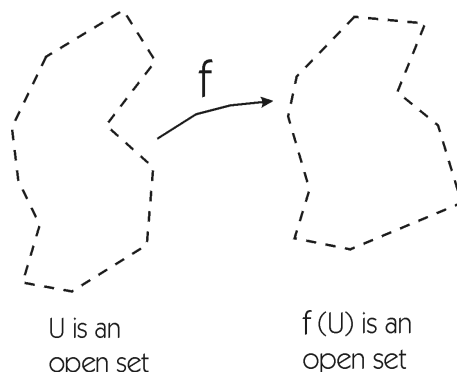


Figure 6.4: The open mapping principle.

- (c) Let U be a domain in \mathbb{C} and $f : U \rightarrow \mathbb{C}$ a holomorphic function. Let $P \in U$ and set $k = |f(P)|$. Then k cannot be the maximum value of $|f|$. For in fact (by part (b)) the image of f must contain an entire neighborhood of $f(P)$. So (see Figure 6.5), it will certainly contain points with modulus larger than k . This is a version of the important *maximum principle* which we shall discuss in some detail below.

In fact the open mapping principle is an immediate consequence of the argument principle. For suppose that $f : U \rightarrow \mathbb{C}$ is holomorphic and that $P \in U$. Write $f(P) = Q$. We may select an $r > 0$ so that $\overline{D}(P, r) \subseteq U$. Let $g(z) = f(z) - Q$. Then g has a zero at P .

The argument principle now tells us that

$$\frac{1}{2\pi i} \oint_{\partial D(P, r)} \frac{g'(z)}{g(z)} dz \geq 1.$$

[We do not write $= 1$ because we do not know the order of vanishing of g —but it is *at least* 1.] In other words,

$$\frac{1}{2\pi i} \oint_{\partial D(P, r)} \frac{f'(z)}{f(z) - Q} dz \geq 1.$$

But now the continuity of the integral tells us that, if we perturb Q by a small amount, then the value of the integral—which still must be an integer!—will not change. So it is still ≥ 1 . This says that f assumes all values that are

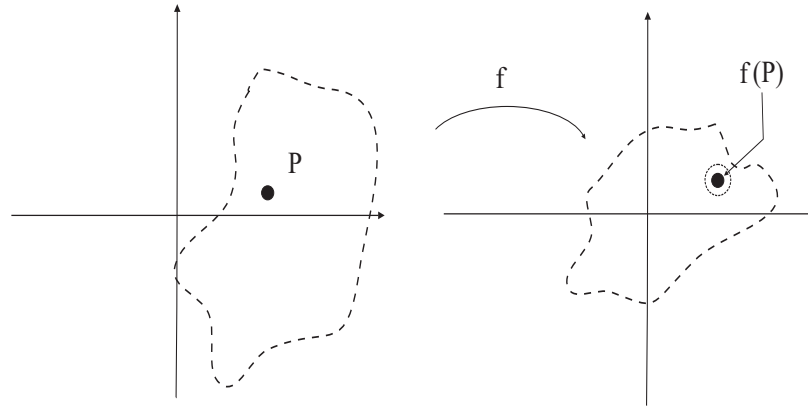


Figure 6.5: The image of f contains a neighborhood of $f(P)$.

near to Q . Which says that the image of f contains a neighborhood of Q ; so it is open. That is the assertion of the open mapping principle.

In the subject of topology, a function f is defined to be continuous if the inverse image of any open set under f is also open. In contexts where the $\epsilon - \delta$ definition makes sense, the $\epsilon - \delta$ definition (Section 2.1.6) is equivalent to the inverse-image-of-open-sets definition. By contrast, functions for which the direct image of any open set is open are called “open mappings.”

Here is a quantitative, or counting, statement that comes from the proof of the open mapping principle: Suppose that $f : U \rightarrow \mathbb{C}$ is a nonconstant holomorphic function on a connected open set U such that $P \in U$ and $f(P) = Q$ with order $k \geq 1$. Then there are numbers $\delta, \epsilon > 0$ such that each $q \in D(Q, \epsilon) \setminus \{Q\}$ has exactly k distinct preimages in $D(P, \delta)$ and each preimage is a simple point of f . This is a striking statement; but all we are saying is that the set of points where f' vanishes cannot have an interior accumulation point. An immediate corollary is that if $f(P) = Q$ and $f'(P) = 0$ then f *cannot* be one-to-one in any neighborhood of P . For $g(z) \equiv f(z) - Q$ vanishes to order at least 2 at P . More generally, if f vanishes to order $k \geq 2$ at P then f is k -to-1 in a deleted neighborhood of P .

The considerations that establish the open mapping principle can also be used to establish the fact that if $f : U \rightarrow V$ is a one-to-one and onto holomorphic function, then $f^{-1} : V \rightarrow U$ is also holomorphic.

Exercises

- Let f be holomorphic on a neighborhood of $\overline{D}(P, r)$. Suppose that f is not identically zero on $D(P, r)$. Prove that f has at most finitely many zeros in $D(P, r)$.
- Let f, g be holomorphic on a neighborhood $\overline{D}(0, 1)$. Assume that f has zeros at $P_1, P_2, \dots, P_k \in D(0, 1)$ and no zero in $\partial D(0, 1)$. Let γ be the boundary circle of $\overline{D}(0, 1)$, traversed counterclockwise. Compute

$$\frac{1}{2\pi i} \oint_{\gamma} \frac{f'(z)}{f(z)} \cdot g(z) dz.$$

- Without supposing that you have any prior knowledge of the calculus function e^x , prove that

$$e^z \equiv \sum_{k=0}^{\infty} \frac{z^k}{k!}$$

never vanishes by computing $(e^z)' / e^z$, and so forth.

- Let $f_n : D(0, 1) \rightarrow \mathbb{C}$ be holomorphic and suppose that each f_n has at least k roots in $D(0, 1)$, counting multiplicities. Suppose that $f_n \rightarrow f$ uniformly on compact sets. Show by example that it does *not* follow that f has at least k roots counting multiplicities. In particular, construct examples, for each fixed k and each ℓ , $0 \leq \ell \leq k$, where f has exactly ℓ roots. What simple hypothesis can you add that will guarantee that f *does* have at least k roots? (Cf. Exercise 8.)
- Let $f : D(0, 1) \rightarrow \mathbb{C}$ be holomorphic and nonvanishing. Prove that f has a well-defined holomorphic logarithm on $D(0, 1)$ by showing that the differential equation

$$\frac{\partial}{\partial z} g(z) = \frac{f'(z)}{f(z)}$$

has a suitable solution and checking that this solution g does the job.

- Let U and V be open subsets of \mathbb{C} . Suppose that $f : U \rightarrow V$ is holomorphic, one-to-one, and onto. Prove that f^{-1} is a holomorphic function on V .

7. Let $f : U \rightarrow \mathbb{C}$ be holomorphic. Assume that $\overline{D}(P, r) \subseteq U$ and that f is nowhere zero on $\partial D(P, r)$. Show that if g is holomorphic on U and g is sufficiently uniformly close to f on $\partial D(P, r)$, then the number of zeros of f in $D(P, r)$ equals the number of zeros of g in $D(P, r)$. (Remember to count zeros according to multiplicity.)
8. What does the open mapping principle say about an incompressible fluid flow? Why does this make good physical sense? Why is it clear that the flow applied to an open region will never have a “boundary?”
9. Suppose that U is a simply connected domain in \mathbb{C} . Let f be a non-vanishing holomorphic function on U . Then f will have a holomorphic logarithm. That logarithm may be defined using a complex line integral [**Hint:** Integrate f'/f .] Write a **MatLab** routine to carry out this procedure in the case that f is a holomorphic polynomial.

6.3 Further Results on the Zeros of Holomorphic Functions

6.3.1 Rouché’s Theorem

Now we consider global aspects of the argument principle.

Suppose that $f, g : U \rightarrow \mathbb{C}$ are holomorphic functions on an open set $U \subseteq \mathbb{C}$. Suppose also that $\overline{D}(P, r) \subseteq U$ and that, for each $\zeta \in \partial D(P, r)$,

$$|f(\zeta) - g(\zeta)| < |f(\zeta)| + |g(\zeta)|. \quad (6.11)$$

Then

$$\frac{1}{2\pi i} \oint_{\partial D(P, r)} \frac{f'(\zeta)}{f(\zeta)} d\zeta = \frac{1}{2\pi i} \oint_{\partial D(P, r)} \frac{g'(\zeta)}{g(\zeta)} d\zeta. \quad (6.12)$$

That is, the number of zeros of f in $D(P, r)$ counting multiplicities equals the number of zeros of g in $D(P, r)$ counting multiplicities. See [GRK] for a more complete discussion and proof of Rouché’s theorem.

Remark: Rouché’s theorem is often stated with the stronger hypothesis that

$$|f(\zeta) - g(\zeta)| < |g(\zeta)| \quad (6.13)$$

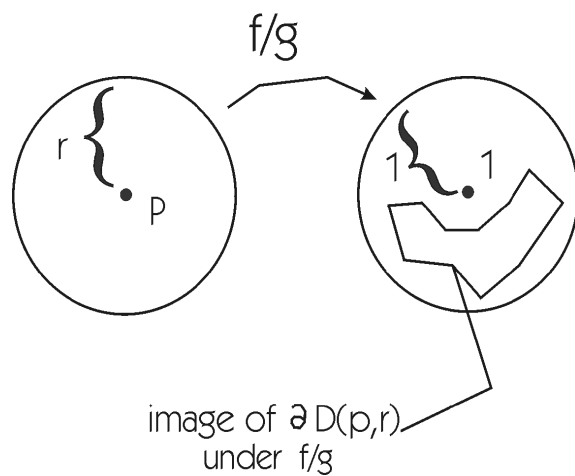


Figure 6.6: Rouché's theorem.

for $\zeta \in \partial D(P, r)$. Rewriting this hypothesis as

$$\left| \frac{f(\zeta)}{g(\zeta)} - 1 \right| < 1, \quad (6.14)$$

we see that it says that the image γ under f/g of the circle $\partial D(P, r)$ lies in the disc $D(1, 1)$. See Figure 6.6. Our weaker hypothesis that $|f(\zeta) - g(\zeta)| < |f(\zeta)| + |g(\zeta)|$ has the geometric interpretation that $f(\zeta)/g(\zeta)$ lies in the set $\mathbb{C} \setminus \{x + i0 : x \leq 0\}$. Either hypothesis implies that the image of the circle $\partial D(P, r)$ under f has the same “winding number” around 0 as does the image under g of that circle. And that is the proof of Rouché's theorem.

6.3.2 Typical Application of Rouché's Theorem

EXAMPLE 50 Let us determine the number of roots of the polynomial $f(z) = z^7 + 5z^3 - z - 2$ in the unit disc. We do so by comparing the function f to the holomorphic function $g(z) = 5z^3$ on the unit circle. For $|z| = 1$ we have

$$|f(z) - g(z)| = |z^7 - z - 2| \leq 4 < 5 = |g(z)| \leq |f(z)| + |g(z)|. \quad (6.15)$$

By Rouché's theorem, f and g have the same number of zeros, counting multiplicity, in the unit disc. Since g has three zeros, so does f . \square

6.3.3 Rouché's Theorem and the Fundamental Theorem of Algebra

Rouché's theorem provides a useful way to locate approximately the zeros of a holomorphic function that is too complicated for the zeros to be obtained explicitly. As an illustration, we analyze the zeros of a nonconstant polynomial

$$p(z) = z^n + a_{n-1}z^{n-1} + a_{n-2}z^{n-2} + \cdots + a_1z + a_0. \quad (6.16)$$

If R is sufficiently large (say $R > \max\{1, n \cdot \max_{0 \leq n \leq n-1} |a_n|\}$) and $|z| = R$, then

$$\frac{|a_{n-1}z^{n-1} + a_{n-2}z^{n-2} + \cdots + a_0|}{|z^n|} < 1. \quad (6.17)$$

Thus Rouché's theorem applies on $\overline{D}(0, R)$ with $f(z) = z^n$ and $g(z) = p(z)$. We conclude that the number of zeros of $p(z)$ inside $D(0, R)$, counting multiplicities, is the same as the number of zeros of z^n inside $D(0, R)$, counting multiplicities—namely n . Thus we recover the Fundamental Theorem of Algebra. Incidentally, this example underlines the importance of counting zeros with multiplicities: the function z^n has only one root in the naïve sense of counting the number of points where it is zero; but it has n roots when they are counted with multiplicity. So Rouché's theorem teaches us that a polynomial of degree n has n zeros—just as it should.

6.3.4 Hurwitz's Theorem

A second useful consequence of the argument principle is the following result about the limit of a sequence of zero-free holomorphic functions:

THEOREM 5 (Hurwitz's Theorem) *Suppose that $U \subseteq \mathbb{C}$ is a connected open set and that $\{f_j\}$ is a sequence of nowhere-vanishing holomorphic functions on U . If the sequence $\{f_j\}$ converges uniformly on compact subsets of U to a (necessarily holomorphic) limit function f_0 , then either f_0 is nowhere-vanishing or $f_0 \equiv 0$.*

The justification for Hurwitz's theorem is again the argument principle. For we know that if $\overline{D}(P, r)$ is a closed disc on which all the f_j are zero-free then

$$\frac{1}{2\pi i} \oint_{\partial D(P, r)} \frac{f_j'(z)}{f_j(z)} dz = 0$$

for every j . The limit function f is surely holomorphic. If it is not identically zero, then suppose seeking a contradiction that it has a zero—which is of course isolated—at some point P . Choose $r > 0$ small so that f has no other zeros on $\overline{D}(P, r)$. Since the f_j (and hence the f'_j) converge uniformly on $\overline{D}(P, r)$, we can be sure that as $j \rightarrow +\infty$ the expression on the left then converges to

$$\frac{1}{2\pi i} \oint_{\partial D(P, r)} \frac{f'(z)}{f(z)} dz.$$

And the value of the integral must be zero. We conclude that f has no zeros in the disc, which is clearly a contradiction. Thus f is either identically zero or zero free.

Exercises

1. How many zeros does the function $f(z) = z^3 + z/2$ have in the unit disc?
2. Consider the sequence of functions $f_j(z) = e^{z/j}$. Discuss this sequence in view of Hurwitz's theorem.
3. Consider the sequence of functions $f_j(z) = \sin(jz)$. Discuss in view of Hurwitz's theorem.
4. Consider the sequence of functions $f_j(z) = \cos(z/j)$. Discuss in view of Hurwitz's theorem.
5. Apply Rouché's theorem to see that e^z cannot vanish on the unit disc.
6. Use Rouché's theorem to give yet another proof of the Fundamental Theorem of Algebra. [**Hint:** If the polynomial has degree n , then compare the polynomial with z^n on a large disc.]
7. Estimate the number of zeros of the given function in the given region U .

(a) $f(z) = z^8 + 5z^7 - 20,$	$U = D(0, 6)$
(b) $f(z) = z^3 - 3z^2 + 2,$	$U = D(0, 1)$
(c) $f(z) = z^{10} + 10z + 9,$	$U = D(0, 1)$

- (d) $f(z) = z^{10} + 10ze^{z+1} - 9$, $U = D(0, 1)$
 (e) $f(z) = z^4e - z^3 + z^2/6 - 10$, $U = D(0, 2)$
 (f) $f(z) = z^2e^z - z$, $U = D(0, 2)$
8. Each of the partial sums of the power series for the function e^z is a polynomial. Hence it has zeros. But the exponential function has no zeros. Discuss in view of Hurwitz's theorem and the argument principle.
9. Each of the partial sums of the power series for the function $\sin z$ is a polynomial, hence it has finitely many zeros. Yet $\sin z$ has infinitely many zeros. Discuss in view of Hurwitz's theorem and the argument principle.
10. How many zeros does $f(z) = \sin z + \cos z$ have in the unit disc?
11. Let $D(P, r)$ be a disc in the complex plane. Let f and g be holomorphic polynomials. Write a `MatLab` routine to test whether Rouché's theorem applies to f and g . Write the routine so that it declares an appropriate conclusion.

6.4 The Maximum Principle

6.4.1 The Maximum Modulus Principle

A *domain* in \mathbb{C} is a connected open set (Section 2.1.1). A *bounded domain* is a connected open set U such that there is an $R > 0$ with $|z| < R$ for all $z \in U$ —or $U \subseteq D(0, R)$.

The Maximum Modulus Principle

Let $U \subseteq \mathbb{C}$ be a domain. Let f be a holomorphic function on U . If there is a point $P \in U$ such that $|f(P)| \geq |f(z)|$ for all $z \in U$, then f is constant.

Here is a sharper variant of the theorem:

Let $U \subseteq \mathbb{C}$ be a domain and let f be a holomorphic function on U . If there is a point $P \in U$ at which $|f|$ has a *local maximum*, then f is constant.

We have already indicated why this result is true; the geometric insight is an important one. Let $k = |f(P)|$. Since $f(P)$ is an *interior point* of the image of f , there will certainly be points—and the proof of the open mapping principle shows that these are nearby points—where f takes values of greater modulus. Hence P cannot be a local maximum.

6.4.2 Boundary Maximum Modulus Theorem

The following version of the maximum principle is intuitively appealing, and is frequently useful.

Let $U \subseteq \mathbb{C}$ be a bounded domain. Let f be a continuous function on \overline{U} that is holomorphic on U . Then the maximum value of $|f|$ on \overline{U} (which must occur, since \overline{U} is closed and bounded—see [RUD1], [KRA2]) must in fact occur on ∂U .

In other words,

$$\max_{\overline{U}} |f| = \max_{\partial U} |f|. \quad (6.18)$$

And the reason for this new assertion is obvious. The maximum must occur somewhere; and it cannot occur in the interior by the previous formulation of the maximum principle. So it must be in the boundary.

6.4.3 The Minimum Modulus Principle

Holomorphic functions (or, more precisely, their moduli) *can* have interior minima. The function $f(z) = z^2$ on $D(0, 1)$ has the property that $z = 0$ is a global minimum for $|f|$. However, it is not accidental that this minimum value is 0:

Let f be holomorphic on a domain $U \subseteq \mathbb{C}$. Assume that f never vanishes. If there is a point $P \in U$ such that $|f(P)| \leq |f(z)|$ for all $z \in U$, then f is constant.

This result is proved by applying the maximum principle to the function $1/f$. There is also a boundary minimum modulus principle:

Let $U \subseteq \mathbb{C}$ be a bounded domain. Let f be a continuous function on \overline{U} that is holomorphic on U . Assume that f never vanishes on \overline{U} . Then the minimum value of $|f|$ on \overline{U} (which must occur, since \overline{U} is closed and bounded—see [RUD1], [KRA2]) must occur on ∂U .

In other words,

$$\min_{\overline{U}} |f| = \min_{\partial U} |f|. \quad (6.19)$$

Exercises

1. Let $U \subseteq \mathbb{C}$ be a bounded domain. If f, g are continuous functions on \overline{U} , holomorphic on U , and if $|f(z)| \leq |g(z)|$ for $z \in \partial U$, then what conclusion can you draw about f and g in the interior of U ?
2. Let $f : \overline{D}(0, 1) \rightarrow \overline{D}(0, 1)$ be continuous and holomorphic on the interior. Further assume that f is one-to-one and onto. Explain why the maximum principle guarantees that $f(\partial D(0, 1)) \subseteq \partial D(0, 1)$.
3. Give an example of a holomorphic function f on $D(0, 1)$ so that $|f|$ has three local minima.
4. Give an example of a holomorphic function f on $D(0, 1)$, continuous on $\overline{D}(0, 1)$, that has precisely three global maxima on $\partial D(0, 1)$.
5. The function

$$f(z) = i \cdot \frac{1 - z}{1 + z}$$

maps the disc $D(0, 1)$ to the upper half-plane $\mathcal{U} = \{z \in \mathbb{C} : \operatorname{Im} z > 0\}$ (the upper half-plane) in a one-to-one, onto fashion. Verify this assertion in the following manner:

- (a) Use elementary algebra to check that f is one-to-one.
- (b) Use just algebra to check that $\partial D(0, 1)$ is mapped to $\partial \mathcal{U}$.
- (c) Check that 0 is mapped to i .
- (d) Invoke the maximum principle to conclude that $D(0, 1)$ is mapped to \mathcal{U} .

6. Let f be meromorphic on a region $U \subseteq \mathbb{C}$. A version of the maximum principle is still valid for such an f . Explain why.
7. Let $U \subseteq \mathbb{C}$ be a domain and let $f : U \rightarrow \mathbb{C}$ be holomorphic. Consider the function $g(z) = e^{f(z)}$. Explain why the maxima of $|g|$ occur precisely at the maxima of $\operatorname{Re} f$. Conclude that a version of the maximum principle holds for $\operatorname{Re} f$. Draw a similar conclusion for $\operatorname{Im} f$.
8. Let $U, V \subseteq \mathbb{C}$ be bounded domains with continuously differentiable boundary. So U and V are open and connected. Let $\varphi : \overline{U} \rightarrow \overline{V}$ be continuous, one-to-one, and onto. And suppose that φ is holomorphic on U (and of course φ^{-1} is holomorphic on V). Show that $\varphi(\partial U) \subseteq \partial V$.
9. Let f be holomorphic on the entire plane \mathbb{C} . Suppose that

$$|f(z)| \leq C \cdot (1 + |z|^k)$$

for all $z \in \mathbb{C}$, some positive constant C and some integer $k > 0$. Prove that f is a polynomial of degree at most k .

10. Let U be a domain in the complex plane. Let f be a holomorphic polynomial. Write a `MatLab` routine that will find the location of the maximum value of $|f|^2$ in U . Apply this routine to various polynomials to confirm that the maximum never occurs on the boundary.
11. Modify the routine from the last exercise so that it applies to the minimum value of $|f|^2$ —in the case that f is nonvanishing on U .
12. Suppose that two incompressible fluid flows are very close together on the boundary of a disc—just as in Rouché’s theorem. What might we expect that this will tell us about the two fluid flows inside the disc? Why?

6.5 The Schwarz Lemma

This section treats certain estimates that must be satisfied by bounded holomorphic functions on the unit disc. We present the classical, analytic viewpoint in the subject (instead of the geometric viewpoint—see [KRA3]).

6.5.1 Schwarz's Lemma

THEOREM 6 *Let f be holomorphic on the unit disc. Assume that*

$$(6.20) \quad |f(z)| \leq 1 \text{ for all } z.$$

$$(6.21) \quad f(0) = 0.$$

Then $|f(z)| \leq |z|$ and $|f'(0)| \leq 1$.

If either $|f(z)| = |z|$ for some $z \neq 0$ or if $|f'(0)| = 1$, then f is a rotation: $f(z) \equiv \alpha z$ for some complex constant α of unit modulus.

Proof: Consider the function $g(z) = f(z)/z$. Since g has a removable singularity at the origin, we see that g is holomorphic on the entire unit disc. On the circle with center 0 and radius $1 - \epsilon$, we see that

$$|g(z)| \leq \frac{1}{1 - \epsilon}.$$

By the maximum modulus principle, it follows that $|g(z)| \leq 1/(1 - \epsilon)$ on all of $\overline{D}(0, 1 - \epsilon)$. Since the conclusion is true for all $\epsilon > 0$, we conclude that $|g| \leq 1$ on $D(0, 1)$.

For the uniqueness, assume that $|f(z)| = |z|$ for some $z \neq 0$. Then $|g(z)| = 1$. Since $|g| \leq 1$ globally, the maximum modulus principle tells us that g is a constant of modulus 1. Thus $f(z) = \alpha z$ for some unimodular constant α . If instead $|f'(0)| = 1$ then $|[g(0) + g'(0) \cdot 0]| = 1$ or $|g(0)| = 1$. Again, the maximum principle tells us that g is a unimodular constant so f is a rotation. \square

Schwarz's lemma enables one to classify the invertible holomorphic self-maps of the unit disc (see [GRK]). (Here a *self-map* of a domain U is a mapping $F : U \rightarrow U$ of the domain to itself.) These are commonly referred to as the "conformal self-maps" of the disc. The classification is as follows: If $0 \leq \theta < 2\pi$, then define the *rotation through angle θ* to be the function $\rho_\theta(z) = e^{i\theta}z$; if a is a complex number of modulus less than one, then define the associated *Möbius transformation* to be $\varphi_a(z) = [z - a]/[1 - \bar{a}z]$. Any conformal self-map of the disc is the composition of some rotation ρ_θ with some Möbius transformation φ_a . This topic is treated in detail in Sections 7.2.1 and 7.2.2.

We conclude this section by presenting a generalization of the Schwarz lemma, in which we consider holomorphic mappings $f : D \rightarrow D$, but we discard the hypothesis that $f(0) = 0$. This result is known as the Schwarz-Pick lemma.

6.5.2 The Schwarz-Pick Lemma

Let f be holomorphic on the unit disc. Assume that

$$(6.22) \quad |f(z)| \leq 1 \text{ for all } z.$$

$$(6.23) \quad f(a) = b \text{ for some } a, b \in D(0, 1).$$

Then

$$|f'(a)| \leq \frac{1 - |b|^2}{1 - |a|^2}. \quad (6.24)$$

Moreover, if $f(a_1) = b_1$ and $f(a_2) = b_2$, then

$$\left| \frac{b_2 - b_1}{1 - \bar{b}_1 b_2} \right| \leq \left| \frac{a_2 - a_1}{1 - \bar{a}_1 a_2} \right|. \quad (6.25)$$

There is a “uniqueness” result in the Schwarz-Pick Lemma. If either

$$|f'(a)| = \frac{1 - |b|^2}{1 - |a|^2} \quad \text{or} \quad \left| \frac{b_2 - b_1}{1 - \bar{b}_1 b_2} \right| = \left| \frac{a_2 - a_1}{1 - \bar{a}_1 a_2} \right| \quad \text{with } a_1 \neq a_2, \quad (6.26)$$

then the function f is a conformal self-mapping (one-to-one, onto holomorphic function) of $D(0, 1)$ to itself.

We cannot discuss the proof of the Schwarz-Pick lemma right now. It depends on knowing the conformal self-maps of the disc—a topic we shall treat later. The reader should at least observe at this time that, in (6.24), if $a = b = 0$ then the result reduces to the classical Schwarz lemma. Further, in (6.25), if $a_1 = b_1 = 0$ and $a_2 = z$, $b_2 = f(z)$, then the result reduces to the Schwarz lemma.

Exercises

1. Let $U = \{z \in \mathbb{C} : \operatorname{Im} z > 0\}$ (the upper half-plane). Formulate and prove a version of the Schwarz lemma for holomorphic functions $f : U \rightarrow U$. [**Hint:** It is useful to note that the mapping $\psi(z) = i(1 - z)/(1 + z)$ maps the unit disc to U in a holomorphic, one-to-one, and onto fashion.]
2. Let U be as in Exercise 1. Formulate and prove a version of the Schwarz lemma for holomorphic functions $f : D(0, 1) \rightarrow U$.
3. There is no Schwarz lemma for holomorphic functions $f : \mathbb{C} \rightarrow \mathbb{C}$. Give a detailed justification for this statement. Can you suggest why the Schwarz lemma fails in this new context?
4. Give a detailed justification for the formula

$$(f^{-1})'(w) = \frac{1}{f'(z)}.$$

Here $f(z) = w$ and f is a holomorphic function. Part of your job here is to provide suitable hypotheses about the function f .

5. Provide the details of the proof of the Schwarz-Pick lemma. [**Hint:** If $f(a) = b$, then consider $g(z) = \varphi_b \circ f \circ \varphi_{-a}$ and apply the Schwarz lemma.]
6. The expression

$$\rho(z, w) = \frac{|z - w|}{|1 - z\bar{w}|}$$

for z, w in the unit disc is called the *pseudohyperbolic metric*. Prove that ρ is actually a metric, or a sense of distance, on the disc. This means that you should verify these properties:

- (i) $\rho(z, w) \geq 0$ for all $z, w \in D(0, 1)$;
- (ii) $\rho(z, w) = 0$ if and only if $z = w$;
- (iii) $\rho(z, w) = \rho(w, z)$;
- (iv) $\rho(z, w) \leq \rho(z, u) + \rho(u, w)$ for all $u, z, w \in D(0, 1)$.

7. Suppose that f is a holomorphic function on a domain $U \subseteq \mathbb{C}$. Assume that $|f(z)| \leq M$ for all $z \in U$ and some $M > 0$. Let $P \in U$. Use the Schwarz lemma to provide an estimate for $|f'(P)|$. [**Hint:** Your estimate will be in terms of M and the distance of P to the boundary of U .]
8. Write a `MatLab` routine that will calculate the pseudohyperbolic metric on the disc. You should be able to input two points from the disc and the routine should output a nonnegative real number that is the distance between them. Use this routine to amass numerical evidence that the distance from any fixed point in the disc to the boundary is infinite.
9. Suppose that $f : D \rightarrow D$ is a holomorphic function, that $f(0) = 0$, and that $\lim_{z \rightarrow \partial D} |f(z)| = 1$. Then of course Schwarz's lemma guarantees that $|f(z)| \leq |z|$ for all $z \in D$. Write a `MatLab` routine to measure the deviation of $|f(z)|$ from $|z|$. Apply it to various specific examples.
10. What does Schwarz's lemma tell us about the geometric characteristics of a fluid flow? How does this differ from an air flow? Why?

Chapter 7

The Geometric Theory of Holomorphic Functions

7.1 The Idea of a Conformal Mapping

7.1.1 Conformal Mappings

The main objects of study in this chapter are holomorphic functions $h : U \rightarrow V$, with U and V open domains in \mathbb{C} , that are one-to-one and onto. Such a holomorphic function is called a *conformal* (or *biholomorphic*) mapping. The fact that h is supposed to be one-to-one implies that h' is nowhere zero on U [remember that if h' vanishes to order $k \geq 1$ at a point $P \in U$, then h is $(k + 1)$ -to-1 in a small neighborhood of P —see Section 6.2.1]. As a result, $h^{-1} : V \rightarrow U$ is also holomorphic—as we discussed in Section 6.2.1. A conformal map $h : U \rightarrow V$ from one open set to another can be used to transfer holomorphic functions on U to V and vice versa: that is, $f : V \rightarrow \mathbb{C}$ is holomorphic if and only if $f \circ h$ is holomorphic on U ; and $g : U \rightarrow \mathbb{C}$ is holomorphic if and only if $g \circ h^{-1}$ is holomorphic on V .

In fact the word “conformal” has a specific geometric meaning—in terms of infinitesimal preservation of length and infinitesimal preservation of angles. These properties in turn have particularly interesting interpretations in the context of incompressible fluid flow (see Section 8.2). In fact we discussed this way of thinking about conformality in Section 2.4.1. We shall explore other aspects of conformal mappings in the material that follows.

Thus, if there is a conformal mapping from U to V , then U and V are essentially indistinguishable from the viewpoint of complex function theory.

On a practical level, one can often study holomorphic functions on a rather complicated open set by first mapping that open set to some simpler open set, then transferring the holomorphic functions as indicated.

The main point now is that we are going to think of our holomorphic function $f : U \rightarrow V$ not as a function but as a mapping. That means that the function is a geometric transformation from the domain U to the domain V . And of course f^{-1} is a geometric transformation from the domain V to the domain U .

7.1.2 Conformal Self-Maps of the Plane

The simplest open subset of \mathbb{C} is \mathbb{C} itself. Thus it is natural to begin our study of conformal mappings by considering the conformal mappings of \mathbb{C} to itself. In fact the conformal mappings from \mathbb{C} to \mathbb{C} can be explicitly described as follows:

A function $f : \mathbb{C} \rightarrow \mathbb{C}$ is a conformal mapping if and only if there are complex numbers a, b with $a \neq 0$ such that

$$f(z) = az + b \quad , \quad z \in \mathbb{C}. \quad (7.1)$$

One aspect of the result is fairly obvious: If $a, b \in \mathbb{C}$ and $a \neq 0$, then the map $z \mapsto az + b$ is certainly a conformal mapping of \mathbb{C} to \mathbb{C} . In fact one checks easily that $z \mapsto (z - b)/a$ is the inverse mapping. The interesting part of the assertion is that these are in fact the only conformal maps of \mathbb{C} to \mathbb{C} .

A generalization of this result about conformal maps of the plane is the following (consult Section 4.1.3 as well as the detailed explanation in [GRK]):

If $h : \mathbb{C} \rightarrow \mathbb{C}$ is a holomorphic function such that

$$\lim_{|z| \rightarrow +\infty} |h(z)| = +\infty, \quad (7.2)$$

then h is a polynomial.

In fact this last assertion is simply a restatement of the fact that if an entire function has a pole at infinity then it is a polynomial. We proved that

fact in Section 5.6. Now if $f : \mathbb{C} \rightarrow \mathbb{C}$ is conformal then it is easy to see that $\lim_{|z| \rightarrow +\infty} |f(z)| = +\infty$ —for both f and f^{-1} take bounded sets to bounded sets. So f will be a polynomial. But if f has degree $k > 1$ then it will not be one-to-one: the equation $f(z) = \alpha$ will always have k roots. Thus f is a first-degree polynomial, which is what has been claimed.

Exercises

1. How many points in the plane uniquely determine a conformal self-map of the plane? That is to say, what is the least k such that if $f(p_1) = p_1$, $f(p_2) = p_2$, \dots , $f(p_k) = p_k$ (with p_1, \dots, p_k distinct) then $f(z) \equiv z$?
2. Let $U = \mathbb{C} \setminus \{0\}$. What are all the conformal self-maps of U to U ?
3. Let $U = \mathbb{C} \setminus \{0, 1\}$. What are all the conformal self-maps of U to U ?
4. The function $f(z) = e^z$ is an onto mapping from \mathbb{C} to $\mathbb{C} \setminus \{0\}$. Prove this statement. The function is certainly *not* one-to-one. But it is *locally* one-to-one. Explain these assertions.
5. Refer to Exercise 4. The point i is in the image of f . Give an explicit description of the inverse of f near i .
6. The function $g(z) = z^2$ is an onto mapping from $\mathbb{C} \setminus \{0\}$ to $\mathbb{C} \setminus \{0\}$. It is certainly *not* one-to-one. But it is *locally* one-to-one. Explain these assertions.
7. The function $f(z) = e^z$ maps the strip $S = \{x + iy : 0 < x < 1\}$ conformally onto an annulus. Describe in detail this image annulus. Explain why the mapping is onto but not one-to-one. Explain why it is locally one-to-one.
8. The function $f(z) = z^2$ maps the quarter-disc $Q = \{x + iy : x > 0, y > 0, x^2 + y^2 < 1\}$ conformally onto the half-disc $H = \{x + iy : y > 0, x^2 + y^2 < 1\}$. Explain why this is a one-to-one, onto mapping.
9. Use what you have learned from the preceding exercises to construct a conformal map of the upper half-plane $\mathcal{U} = \{x + iy : y > 0\}$ onto the upper half-disc $H = \{x + iy : y > 0, x^2 + y^2 < 1\}$.

10. A conformal mapping should map a fluid flow to another fluid flow. Discuss why this should be true. Referring to Section 2.4, consider specifically the property of conformality and why that should be preserved.
11. Use `MatLab` to write a utility that will test a given function for conformality. That is, you should input the function itself, a base point, and two directions; the utility will test whether the function stretches equally in each direction. Or you can input the function, a base point, a direction, and an angle; the utility will test whether that angle is preserved.

7.2 Conformal Mappings of the Unit Disc

7.2.1 Conformal Self-Maps of the Disc

In this section we describe the set of all conformal maps of the unit disc to itself. Our first step is to determine those conformal maps of the disc to the disc that fix the origin. Let D denote the unit disc.

Let us begin by examining a conformal mapping $f : D \rightarrow D$ of the unit disc to itself such that $f(0) = 0$. We are assuming that f is one-to-one and onto. Then, by Schwarz's lemma (Section 6.5), $|f'(0)| \leq 1$. This reasoning applies to f^{-1} as well, so that $|(f^{-1})'(0)| \leq 1$ or $|f'(0)| \geq 1$. We conclude that $|f'(0)| = 1$. By the uniqueness part of the Schwarz lemma, f must be a rotation. So there is a complex number ω with $|\omega| = 1$ such that

$$f(z) \equiv \omega z \quad \forall z \in D. \quad (7.3)$$

It is often convenient to write a rotation as

$$\rho_\theta(z) \equiv e^{i\theta} z, \quad (7.4)$$

where we have set $\omega = e^{i\theta}$ with $0 \leq \theta < 2\pi$.

We will next generalize this result to conformal self-maps of the disc that do not necessarily fix the origin.

7.2.2 Möbius Transformations

For $a \in \mathbb{C}$, $|a| < 1$, we define

$$\varphi_a(z) = \frac{z - a}{1 - \bar{a}z}. \quad (7.5)$$

Then each φ_a is a conformal self-map of the unit disc.

To see this assertion, note that if $|z| = 1$, then

$$|\varphi_a(z)| = \left| \frac{z - a}{1 - \bar{a}z} \right| = \left| \frac{\bar{z}(z - a)}{1 - \bar{a}z} \right| = \left| \frac{1 - a\bar{z}}{1 - \bar{a}z} \right| = 1. \quad (7.6)$$

Thus φ_a takes the boundary of the unit disc to itself. Since $\varphi_a(0) = -a \in D$, we conclude that φ_a maps the unit disc to itself. The same reasoning applies to $(\varphi_a)^{-1} = \varphi_{-a}$, hence φ_a is a one-to-one conformal map of the disc to the disc.

The biholomorphic self-mappings of D can now be completely characterized.

7.2.3 Self-Maps of the Disc

Let $f : D \rightarrow D$ be a holomorphic function. Then f is a conformal self-map of D if and only if there are complex numbers a, ω with $|\omega| = 1, |a| < 1$ such that

$$f(z) = \omega \cdot \varphi_a(z) \quad \forall z \in D. \quad (7.7)$$

In other words, any conformal self-map of the unit disc to itself is the composition of a Möbius transformation with a rotation.

It can also be shown that any conformal self-map f of the unit disc can be written in the form

$$f(z) = \varphi_b(\eta \cdot z), \quad (7.8)$$

for some Möbius transformation φ_b and some complex number η with $|\eta| = 1$.

The reasoning is as follows: Let $f : D \rightarrow D$ be a conformal self-map of the disc and suppose that $f(0) = a \in D$. Consider the new holomorphic mapping $g = \varphi_a \circ f$. Then $g : D \rightarrow D$ is conformal and $g(0) = 0$. By what we learned in Section 7.2.1, $g(z) = \omega \cdot z$ for some unimodular ω . But this says that $f(z) = (\varphi_a)^{-1}(\omega \cdot z)$ or

$$f(z) = \varphi_{-a}(\omega z).$$

That is formulation (7.8) of our result. We invite the reader to find a proof of (7.7).

EXAMPLE 51 Let us find a conformal map of the disc to the disc that takes $i/2$ to $2/3 - i/4$.

We know that $\varphi_{i/2}$ takes $i/2$ to 0. And we know that $\varphi_{-2/3+i/4}$ takes 0 to $2/3 - i/4$. Thus

$$\psi = \varphi_{-2/3+i/4} \circ \varphi_{i/2}$$

has the desired property. □

Exercises

1. Use the definition of the Möbius transformations in line (7.5) to prove directly that if $|z| < 1$ then $|\varphi_a(z)| < 1$.
2. Give a conformal self-map of the disc that sends $i/4 - 1/2$ to $i/3$.
3. Let a_1, a_2, b_1, b_2 be arbitrary points of the unit disc. Explain why there does not necessarily exist a holomorphic function from $D(0, 1)$ to $D(0, 1)$ such that $f(a_1) = b_1$ and $f(a_2) = b_2$.
4. Let $\mathcal{U} = \{z \in \mathbb{C} : \text{Im } z > 0\}$ (the upper half-plane). Calculate all the conformal self-mappings of \mathcal{U} to \mathcal{U} . [**Hint:** The function $\psi(z) = i(1 - z)/(1 + z)$ maps the unit disc D to \mathcal{U} conformally.]
5. Let \mathcal{U} be as in Exercise 4. Calculate all the conformal maps of $D(0, 1)$ to \mathcal{U} .
6. Let $P \in \mathbb{C}$ and $r > 0$. Calculate all the conformal self-maps of $D(P, r)$ to $D(P, r)$.
7. Let $U = D(0, 1) \setminus \{0\}$. Calculate all the conformal self-maps of U to U .
8. Use **MatLab** to write a utility that will construct a conformal self-map of the unit disc that maps a given input point a to another specified point b . Can you refine this utility so that it allows you to make some specifications about the derivative of the function at a ?
9. It is a fact that there is a holomorphic function from the disc to the disc that maps two points a_1 and a_2 to two other specified points b_1 and b_2 if and only if the pseudohyperbolic distance of b_1 to b_2 is less than or equal to the pseudohyperbolic distance of a_1 to a_2 (see Exercise 6 in Section 6.5). Write a **MatLab** utility that will test for this condition. Write a more sophisticated utility that will actually produce the function.

10. Describe in the language of Euclidean geometry (that is, using words) what the Möbius transformation $\varphi_{1/2}$ does to the unit disc. What about iterates $\varphi \circ \varphi$, $\varphi \circ \varphi \circ \varphi$, etc.? Can you interpret this geometric action in terms of flows?

7.3 Linear Fractional Transformations

7.3.1 Linear Fractional Mappings

The automorphisms (that is, conformal self-mappings) of the unit disc D are special cases of functions of the form

$$z \mapsto \frac{az + b}{cz + d}, \quad a, b, c, d \in \mathbb{C}. \quad (7.9)$$

It is worthwhile to consider functions of this form in generality. One restriction on this generality needs to be imposed, however; if $ad - bc = 0$, then the numerator is a constant multiple of the denominator provided that the denominator is not identically zero. So if $ad - bc = 0$, then the function is either constant or has zero denominator and is nowhere defined. Thus only the case $ad - bc \neq 0$ is worth considering in detail.

A function of the form

$$z \mapsto \frac{az + b}{cz + d}, \quad ad - bc \neq 0, \quad (7.10)$$

is called a *linear fractional transformation*.

Note that $(az + b)/(cz + d)$ is not necessarily defined for all $z \in \mathbb{C}$. Specifically, if $c \neq 0$, then it is undefined at $z = -d/c$. In case $c \neq 0$,

$$\lim_{z \rightarrow -d/c} \left| \frac{az + b}{cz + d} \right| = \lim_{z \rightarrow -d/c} \left| \frac{az/c + b/c}{z + d/c} \right| = +\infty. \quad (7.11)$$

This observation suggests that one might well, for linguistic convenience, adjoin formally a “point at ∞ ” to \mathbb{C} and consider the value of $(az + b)/(cz + d)$ to be ∞ when $z = -d/c$ ($c \neq 0$). Thus we will think of both the domain and the range of our linear fractional transformation to be $\mathbb{C} \cup \{\infty\}$ (we sometimes also use the notation $\widehat{\mathbb{C}}$ instead of $\mathbb{C} \cup \{\infty\}$). Specifically, we are led to the following alternative method for describing a linear fractional transformation.

A function $f : \mathbb{C} \cup \{\infty\} \rightarrow \mathbb{C} \cup \{\infty\}$ is a *linear fractional transformation* if there exists $a, b, c, d \in \mathbb{C}$, $ad - bc \neq 0$, such that either

(a) $c = 0, d \neq 0, f(\infty) = \infty$, and $f(z) = (a/d)z + (b/d)$ for all $z \in \mathbb{C}$;

or

(b) $c \neq 0, f(\infty) = a/c, f(-d/c) = \infty$, and $f(z) = (az + b)/(cz + d)$ for all $z \in \mathbb{C}, z \neq -d/c$.

It is important to realize that, as before, the status of the point ∞ is entirely formal: we are just using it as a linguistic convenience, to keep track of the behavior of $f(z)$ both where it is not defined as a map on \mathbb{C} and to keep track of its behavior when $|z| \rightarrow +\infty$. The justification for the particular devices used is the fact that

(c) $\lim_{|z| \rightarrow +\infty} f(z) = f(\infty)$ [$c = 0$; case **(a)** of the definition];

(d) $\lim_{z \rightarrow -d/c} |f(z)| = +\infty$ [$c \neq 0$; case **(b)** of the definition].

7.3.2 The Topology of the Extended Plane

The limit properties of f that we described in Section 7.3.1 can be considered as continuity properties of f from $\mathbb{C} \cup \{\infty\}$ to $\mathbb{C} \cup \{\infty\}$ using the definition of continuity that comes from the topology on $\mathbb{C} \cup \{\infty\}$ (which we are about to define). It is easy to formulate that topology in terms of open sets. But it is also convenient to formulate that same topological structure in terms of convergence of sequences:

A sequence $\{j\}$ in $\mathbb{C} \cup \{\infty\}$ converges to $p_0 \in \mathbb{C} \cup \{\infty\}$ (notation $\lim_{j \rightarrow \infty} p_j = p_0$) if either

(e) $p_0 = \infty$ and $\lim_{j \rightarrow +\infty} |p_j| = +\infty$ where the limit is taken for all j such that $p_j \in \mathbb{C}$ (the limit here means that the $|p_j|$ are getting ever larger as $j \rightarrow +\infty$);

or

(f) $p_0 \in \mathbb{C}$, all but a finite number of the p_j are in \mathbb{C} , and $\lim_{j \rightarrow \infty} p_j = p_0$ in the usual sense of convergence in \mathbb{C} .

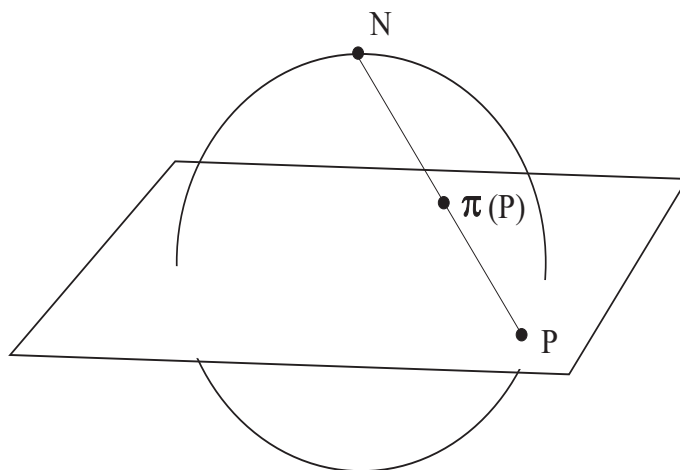


Figure 7.1: Stereographic projection.

7.3.3 The Riemann Sphere

Stereographic projection puts $\widehat{\mathbb{C}} = \mathbb{C} \cup \{\infty\}$ into one-to-one correspondence with the two-dimensional sphere S in \mathbb{R}^3 , $S = \{(x, y, z) \in \mathbb{R}^3 : x^2 + y^2 + z^2 = 1\}$, in such a way that the topology is preserved in both directions of the correspondence.

In detail, begin by imagining the unit sphere bisected by the complex plane with the center of the sphere $(0, 0, 0)$ coinciding with the origin in the plane—see Figure 7.1. We define the stereographic projection as follows: If $P = (x, y) \in \mathbb{C}$, then connect P to the “north pole” N of the sphere with a line segment. The point $\pi(P)$ of intersection of this segment with the sphere is called the *stereographic projection* of P . Note that, under stereographic projection, the “point at infinity” in the plane corresponds to the north pole N of the sphere. For this reason, $\mathbb{C} \cup \{\infty\}$ is often thought of as “being” a sphere, and is then called, for historical reasons, the *Riemann sphere*.

The construction we have just described is another way to think about the “extended complex plane”—see Section 7.3.2. In these terms, linear fractional transformations become homeomorphisms of $\mathbb{C} \cup \{\infty\}$ to itself. (Recall that a *homeomorphism* is, by definition, a one-to-one, onto, continuous mapping with a continuous inverse.)

If $f : \mathbb{C} \cup \{\infty\} \rightarrow \mathbb{C} \cup \{\infty\}$ is a linear fractional transformation,

then f is a one-to-one, onto, continuous function. Also, $f^{-1} : \mathbb{C} \cup \{\infty\} \rightarrow \mathbb{C} \cup \{\infty\}$ is a linear fractional transformation, and is thus a one-to-one, onto, continuous function.

If $g : \mathbb{C} \cup \{\infty\} \rightarrow \mathbb{C} \cup \{\infty\}$ is also a linear fractional transformation, then $f \circ g$ is a linear fractional transformation.

The simplicity of language obtained by adjoining ∞ to \mathbb{C} (so that the composition and inverse properties of linear fractional transformations obviously hold) is well worth the trouble. Certainly one does not wish to consider the multiplicity of special possibilities when composing $(Az + B)/(Cz + D)$ with $(az + b)/(cz + d)$ (namely $c = 0, c \neq 0, aC + cD \neq 0, aC + cD = 0$, etc.) that arise every time composition is considered.

In fact, it is worth summarizing what we have learned in a theorem (see Section 7.3.4). First note that it makes sense now to talk about a homeomorphism from $\mathbb{C} \cup \{\infty\}$ to $\mathbb{C} \cup \{\infty\}$ being conformal: this just means that it, and hence its inverse, are holomorphic in our extended sense. More precisely, a function g is holomorphic at the point ∞ if $g(1/z)$ is holomorphic at the origin. A function h which takes the value ∞ at p is holomorphic at p if $1/h$ is holomorphic at p .

If φ is a conformal map of $\mathbb{C} \cup \{\infty\}$ to itself, then, after composing with a linear fractional transformation, we may suppose that φ maps ∞ to itself. Thus φ , after composition with a linear fraction transformation, is linear. It follows that the original φ itself is linear fractional. The following result summarizes the situation:

7.3.4 Conformal Self-Maps of the Riemann Sphere

THEOREM 7 *A function φ is a conformal self-mapping of $\widehat{\mathbb{C}} = \mathbb{C} \cup \{\infty\}$ to itself if and only if φ is linear fractional.*

We turn now to the actual utility of linear fractional transformations (beyond their having been the form of automorphisms of D —see Sections 7.2.1 through 7.2.3—and the form of all conformal self maps of $\mathbb{C} \cup \{\infty\}$ to itself in the present section). One of the most frequently occurring uses is the following:

7.3.5 The Cayley Transform

The Cayley Transform The linear fractional transformation $c : z \mapsto (i - z)/(i + z)$ maps the upper half-plane $\mathcal{U} = \{z : \operatorname{Im}z > 0\}$ conformally onto the unit disc $D = \{z : |z| < 1\}$.

In fact we may verify this assertion in detail. For $c(0) = 1$, $c(1) = i$, and $c(-1) = -i$. So point of $\partial\mathcal{U}$ get mapped to points of $\partial D(0, 1)$. More generally, if $z \in \partial\mathcal{U}$ then $z = x$ is a real number and

$$c(x) = \frac{i - x}{i + x} = \frac{1 - x^2}{1 + x^2} + i \cdot \frac{2x}{1 + x^2}.$$

Notice that

$$\left[\frac{1 - x^2}{1 + x^2}\right]^2 + \left[\frac{2x}{1 + x^2}\right]^2 = 1,$$

so $c(x)$ is a point of the unit circle. Of course the map c is invertible, so c is a one-to-one correspondence between the real line (which is the boundary of the upper half-plane \mathcal{U}) with the unit circle (which is the boundary of the unit disc $D(0, 1)$). Since $c(i) = 0$, we may conclude that c maps the upper half-plane conformally to the unit disc.

7.3.6 Generalized Circles and Lines

Calculations of the type that we have been discussing are straightforward but tedious. It is thus worthwhile to seek a simpler way to understand what the image under a linear fractional transformation of a given region is. For regions bounded by line segments and arcs of circles the following result gives a method for addressing this issue:

Let \mathcal{C} be the set of subsets of $\mathbb{C} \cup \{\infty\}$ consisting of (i) circles and (ii) sets of the form $L \cup \{\infty\}$ where L is a line in \mathbb{C} . We call the elements of \mathcal{C} “generalized circles.” Then every linear fractional transformation φ takes elements of \mathcal{C} to elements of \mathcal{C} . One verifies this last assertion by noting that any linear fractional transformation is the composition of dilations, translations, and the inversion map $z \mapsto 1/z$; and each of these component maps clearly sends generalized circles to generalized circles.

7.3.7 The Cayley Transform Revisited

To illustrate the utility of this last result, we return to the Cayley transformation

$$z \mapsto \frac{i-z}{i+z}. \quad (7.12)$$

Under this mapping the point ∞ is sent to -1 , the point 1 is sent to $(i-1)/(i+1) = i$, and the point -1 is sent to $(i-(-1))/(i+(-1)) = -i$. Thus the image under the Cayley transform (a linear fractional transformation) of three points on $\mathbb{R} \cup \{\infty\}$ contains three points on the unit circle. Since three points determine a (generalized) circle, and since linear fractional transformations send generalized circles to generalized circles, we may conclude that the Cayley transform sends the real line to the unit circle. Now the Cayley transform is one-to-one and onto from $\mathbb{C} \cup \{\infty\}$ to $\mathbb{C} \cup \{\infty\}$. By continuity, it either sends the upper half-plane to the (open) unit disc or to the complement of the closed unit disc. The image of i is 0 , so in fact the Cayley transform sends the upper half-plane to the unit disc.

7.3.8 Summary Chart of Linear Fractional Transformations

The next chart summarizes the properties of some important linear fractional transformations. Note that $\mathcal{U} = \{z \in \mathbb{C} : \text{Im } z > 0\}$ is the upper half-plane and $D = \{z \in \mathbb{C} : |z| < 1\}$ is the unit disc; the domain variable is z and the range variable is w .

Linear Fractional Transformations

Domain	Image	Conditions	Formula
$z \in \widehat{\mathbb{C}}$	$w \in \widehat{\mathbb{C}}$		$w = \frac{az+b}{cz+d}$
$z \in D$	$w \in \mathcal{U}$		$w = i \cdot \frac{1-z}{1+z}$
$z \in \mathcal{U}$	$w \in D$		$w = \frac{i-z}{i+z}$
$z \in D$	$w \in D$		$w = \frac{z-a}{1-\bar{a}z}$
$z \in \mathbb{C}$	$w \in \mathbb{C}$	$L(z_1) = w_1$	$L(z) = S^{-1} \circ T$
		$L(z_2) = w_2$	$T(z) = \frac{z-z_1}{z-z_3} \cdot \frac{z_2-z_3}{z_2-z_1}$
		$L(z_3) = w_3$	$S(w) = \frac{w-w_1}{w-w_3} \cdot \frac{w_2-w_3}{w_2-w_1}$

Exercises

1. Calculate the inverse of the Cayley transform.
2. Calculate all the conformal mappings of the unit disc to the upper half-plane.
3. Calculate all the conformal mappings from $U = \{z \in \mathbb{C} : \operatorname{Re}((3 - i) \cdot z) > 0\}$ to $V = \{z \in \mathbb{C} : \operatorname{Re}((4 + 2i) \cdot z) > 0\}$.
4. Calculate all the conformal mappings from the disc $D(p, r)$ to the disc $D(P, R)$.
5. How many points in the Riemann sphere uniquely determine a linear fractional transformation?
6. Prove that a linear fractional transformation

$$\varphi(z) = \frac{az + b}{cz + d}$$

preserves the upper half-plane if and only if $ad - bc > 0$.

7. Which linear fractional transformations preserve the real line? Which preserve the unit circle?
8. Let ℓ be a linear fractional transformation and C a circle in the plane. What is a quick test to determine whether ℓ maps C to another circle (rather than a line)?
9. Let ℓ be a linear fractional transformation and L a line in the plane. What is a quick test to determine whether ℓ maps L to another line (rather than a circle)?
10. Write a `MatLab` utility that will apply a given linear fractional transformation to a given line and produce this information: **(i)** Whether the image of the line under the linear fractional transformation another line or a circle; **(ii)** What is the formula for the image, whether it is a line or a circle. Now write a second utility for circles.
11. Every linear fractional transformation can be written as the composition of a translation, a dilation, and an inversion ($z \mapsto 1/z$). Write a `MatLab` utility that will perform this decomposition explicitly.

12. Construe the idea of the “point at infinity” and the Riemann sphere in terms of fluid flow. Think of infinity as being either a sink or a source. How does the mapping $z \mapsto 1/z$ help you to interpret this concept?

7.4 The Riemann Mapping Theorem

7.4.1 The Concept of Homeomorphism

Two open sets U and V in \mathbb{C} are *homeomorphic* if there is a one-to-one, onto, continuous function $f : U \rightarrow V$ with $f^{-1} : V \rightarrow U$ also continuous. Such a function f is called a *homeomorphism* from U to V (see also Section 7.3.3).

7.4.2 The Riemann Mapping Theorem

The Riemann mapping theorem, sometimes called the greatest theorem of the nineteenth century, asserts in effect that any planar domain (other than \mathbb{C} itself) that has the topology of the unit disc also has the conformal structure of the unit disc. Even though this theorem has been subsumed by the great uniformization theorem of Kőbe (see [FAK]), it is still striking in its elegance and simplicity:

If U is an open subset of \mathbb{C} , $U \neq \mathbb{C}$, and if U is homeomorphic to D , then U is conformally equivalent to D . That is, there is a holomorphic mapping $\psi : U \rightarrow D$ which is one-to-one and onto.

7.4.3 The Riemann Mapping Theorem: Second Formulation

An alternative formulation of this theorem uses the concept of “simply connected” (see also Section 3.1.2). We say that a connected open set U in the complex plane is simply connected if any closed curve in U can be continuously deformed to a point. (This is just a precise way of saying that U has no holes. Yet another formulation of the notion is that the complement of U has only one connected component—refer to [GRK].) See Figure 7.2.

Theorem: If U is an open subset of \mathbb{C} , $U \neq \mathbb{C}$, and if U is simply connected, then U is conformally equivalent to D .

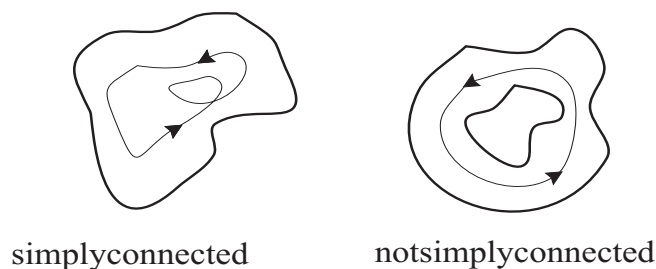


Figure 7.2: Simple connectivity.

Exercises

1. Explain why the Riemann mapping theorem must exclude the entire plane as a candidate for being conformally equivalent to the unit disc.
2. The Riemann mapping theorem is an astonishing result. One corollary is that any simply connected open set in the plane is homeomorphic to the disc, which is in turn homeomorphic to the plane. Explain, remembering that the Riemann mapping theorem does not apply to the case when the domain in question is the entire plane.
3. Let $U \subseteq \mathbb{C}$ be a proper subset that is simply connected. Let $a \in U$. Show that there is a unique conformal mapping φ of the unit disc $D(0, 1)$ to U with the property that $\varphi(0) = a$ and $\varphi'(0) > 0$.
4. Let $U \subseteq \mathbb{C}$ be a proper subset that is simply connected. Let $a, b \in U$ be arbitrary elements. Explain why there is not necessarily a conformal mapping $\varphi : D(0, 1) \rightarrow U$ such that $\varphi(0) = a$ and $\varphi(1/2) = b$. Give an explicit example where there is no mapping.
5. Let $A = \{z \in \mathbb{C} : 1/2 < |z| < 2\}$. Define a holomorphic function φ on A by $\varphi(z) = z + 1/z$. Explain why this is a mapping of A onto the interior of an ellipse. What ellipse is it? Why does this example not contradict the dictum that linear fractional transformations take lines and circles to lines and circles?
6. The Riemann mapping theorem guarantees (abstractly) that there is a conformal map of the strip $\{z \in \mathbb{C} : |\operatorname{Im} z| < 1\}$ onto the unit disc. Write down this mapping explicitly.

7. The Riemann mapping theorem guarantees (abstractly) that there is a conformal map of the quarter-plane $\{z = x + iy \in \mathbb{C} : x > 0, y > 0\}$ to the unit disc. Write down this mapping explicitly.
8. What does the Riemann mapping theorem say about flows? How is the flow on a disc related to the flow on a long, thin strip?
9. Calculate all the conformal self-mappings of the strip $\{z \in \mathbb{C} : |\operatorname{Im} z| < 1\}$.

7.5 Conformal Mappings of Annuli

7.5.1 A Mapping Theorem for Annuli

The Riemann mapping theorem tells us that, from the point of view of complex analysis, there are only two simply connected planar domains: the disc and the plane. Any other simply connected region is biholomorphic to one of these. It is natural then to ask about domains with holes. Take, for example, a domain U with precisely one hole. Is it conformally equivalent to an annulus?

Note that, if $c > 0$ is a constant, then for any $R_1 < R_2$ the annuli

$$A_1 \equiv \{z : R_1 < |z| < R_2\} \quad \text{and} \quad A_2 \equiv \{z : cR_1 < |z| < cR_2\} \quad (7.13)$$

are biholomorphically equivalent under the mapping $z \mapsto cz$. The surprising fact that we shall learn is that these are the *only* circumstances under which two annuli are equivalent:

7.5.2 Conformal Equivalence of Annuli

Let

$$A_1 = \{z \in \mathbb{C} : 1 < |z| < R_1\} \quad (7.14)$$

and

$$A_2 = \{z \in \mathbb{C} : 1 < |z| < R_2\}. \quad (7.15)$$

Then A_1 is conformally equivalent to A_2 if and only if $R_1 = R_2$.

A perhaps more striking result, and more difficult to prove, is this:

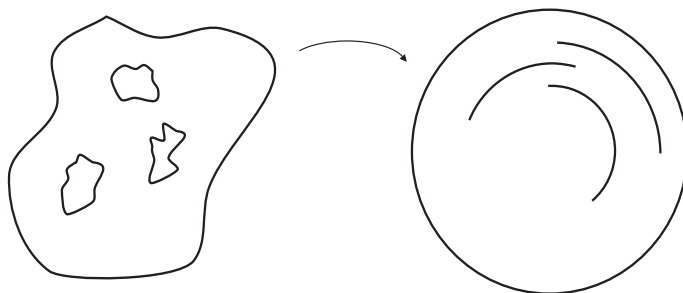


Figure 7.3: Representation of a domain on the disc with circular arcs removed.

Let $U \subseteq \mathbb{C}$ be any bounded domain with *one hole*—this means that the complement of U has two connected components, one bounded and one not. Then U is conformally equivalent to some annulus.

The proofs of these results are rather deep and difficult. We cannot discuss them in any detail here, but include their statements for completeness. See [AHL], [GRK], and [KRA4] for discursive discussions of these theorems.

7.5.3 Classification of Planar Domains

The classification of planar domains up to biholomorphic equivalence is a part of the theory of Riemann surfaces. For now, we comment that one of the startling classification theorems (a generalization of the Riemann mapping theorem) is that any bounded planar domain with finitely many “holes” is conformally equivalent to the unit disc with finitely many closed circular arcs, coming from circles centered at the origin, removed. See Figure 7.3. (Here a “hole” in the present context means a bounded, connected component of the complement of the domain in \mathbb{C} , a concept which coincides with the intuitive idea of a hole.) An alternative equivalent statement is that any bounded planar domain with finitely many holes is conformally equivalent to the plane with finitely many vertical slits centered on the x -axis removed (see [AHL] or [KRA4]). Refer to Figure 7.4. The analogous result for domains with infinitely many holes is known to be true when the number of holes is countable (see [HES]).

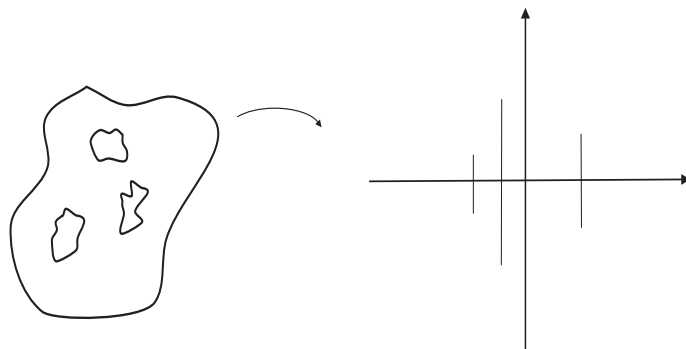


Figure 7.4: Representation of a domain on the plane with vertical slits removed.

Exercises

1. How much data is needed to uniquely determine a conformal mapping of annuli? Suppose that $A_1 = \{z \in \mathbb{C} : 1/2 < |z| < 2\}$ and $A_2 = \{z \in \mathbb{C} : 1 < |z| < 4\}$. Say that f is a conformal mapping of A_1 to A_2 such that $f(1) = 2$. Is there only one such mapping?
2. Define the annulus $A = \{z \in \mathbb{C} : 1/2 < |z| < 2\}$. Certainly any rotation is a conformal self-mapping of A . Also the inversion $\psi : z \mapsto 1/z$ is a conformal mapping of A to itself. Verify these assertions. Can you think of any other conformal mappings of A to A ?
3. Let A be an annulus and ℓ a linear fractional transformation. What can the image of A under ℓ be? Describe all the possibilities.
4. What is the image of the half-plane $\{z \in \mathbb{C} : \operatorname{Re} z < 0\}$ under the mapping $z \mapsto e^z$? Is the mapping one-to-one?
5. What is the image of the strip $\{z \in \mathbb{C} : 1 < \operatorname{Re} z < 2\}$ under the mapping $z \mapsto e^z$? Is the mapping one-to-one?
6. Consider the region $U = \widehat{\mathbb{C}} \setminus \{z \in \mathbb{C} : \operatorname{Im} z = 0, 0 < \operatorname{Re} z < 1\}$. The image of U under the mapping $z \mapsto 1/z$ is the slit plane $V = \mathbb{C} \setminus \{z \in \mathbb{C} : \operatorname{Im} z = 0, 0 < \operatorname{Re} z < 1\}$. Verify this assertion. Draw a picture of the domain and range of this function. Now apply the mapping $z \mapsto \sqrt{z}$

to V . The result is a half-plane. Finally, a suitable Cayley transform will take that last half-plane to the unit disc. Thus the original region $U \subseteq \widehat{\mathbb{C}}$ is conformally equivalent to the unit disc.

7. It is a fact that a conformal self-mapping f of *any* planar domain that has three fixed points (a *fixed point* is a point z such that $f(z) = z$) is the identity mapping (see [FIF], [LES], [MAS]). Show that there is a nontrivial conformal self-map of the annulus $A = \{z \in \mathbb{C} : 1/2 < |z| < 2\}$ having two distinct fixed points.
8. Refer to the last exercise for background. Show that any conformal self-map of the disc having two distinct fixed points is in fact the identity. Show that if we consider conformal self-mappings of the disc and ask how many *boundary* fixed points force the mapping to be the identity then the answer is “three.”
9. Write a `MatLab` utility that will calculate the composition of two given linear fractional transformations. Write another that will calculate the inverse of a given linear fractional transformation.
10. It is very natural to consider fluid flow on an annulus. We may consider clockwise flow and counterclockwise flow. Give a physical interpretation for the statement embodied in lines (7.14) and (7.15).

7.6 A Compendium of Useful Conformal Mappings

Here we present a graphical compendium of commonly used conformal mappings. Most of the mappings that we present here are given by explicit formulas, and are also represented in figures. Wherever possible, we also provide the inverse of the mapping.

In each case, the domain of the mapping is the z -plane, with $x + iy = z \in \mathbb{C}$. And the range of the mapping is the w -plane, with $u + iv = w \in \mathbb{C}$. In some examples, it is appropriate to label special points a, b, c, \dots in the domain of the mapping and then to specify their image points A, B, C, \dots in the range. In other words, if the mapping is called f , then $f(a) = A$, $f(b) = B$, $f(c) = C$, etc.

All of the mappings presented here map the shaded region in the z -plane *onto* the shaded region in the w -plane. Most of the mappings are one-to-one (that is, they do *not* map two distinct points in the domain of the mapping to the same point in the range of the mapping). In a few exceptional cases the mapping is *not* one-to-one; these examples will be clear from context. Figure 7.5 shows conformal mappings of the unit disc.

In the majority of these examples, the mapping is given by an explicit formula. In some cases, such as the Schwarz-Christoffel mapping, the mapping is given by a semi-explicit integral. Such integrals cannot be evaluated

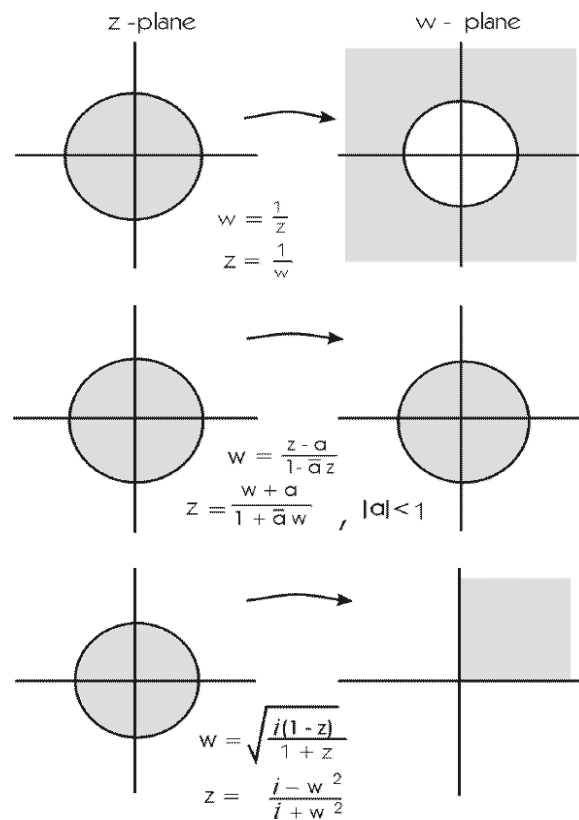


Figure 7.5: **(top)** Map of the disc to its complement; **(middle)** map of the disc to the disc; **(bottom)** map of the disc to the first quadrant.

in closed form. But they can be calculated to any degree of accuracy using methods of numerical integration. Section 8.4 will also provide some information about numerical techniques of conformal mapping. The book [KOB]

gives an extensive listing of explicit conformal mappings; see also [CCP]. The book [NEH] is a classic treatise on the theory of conformal mappings.

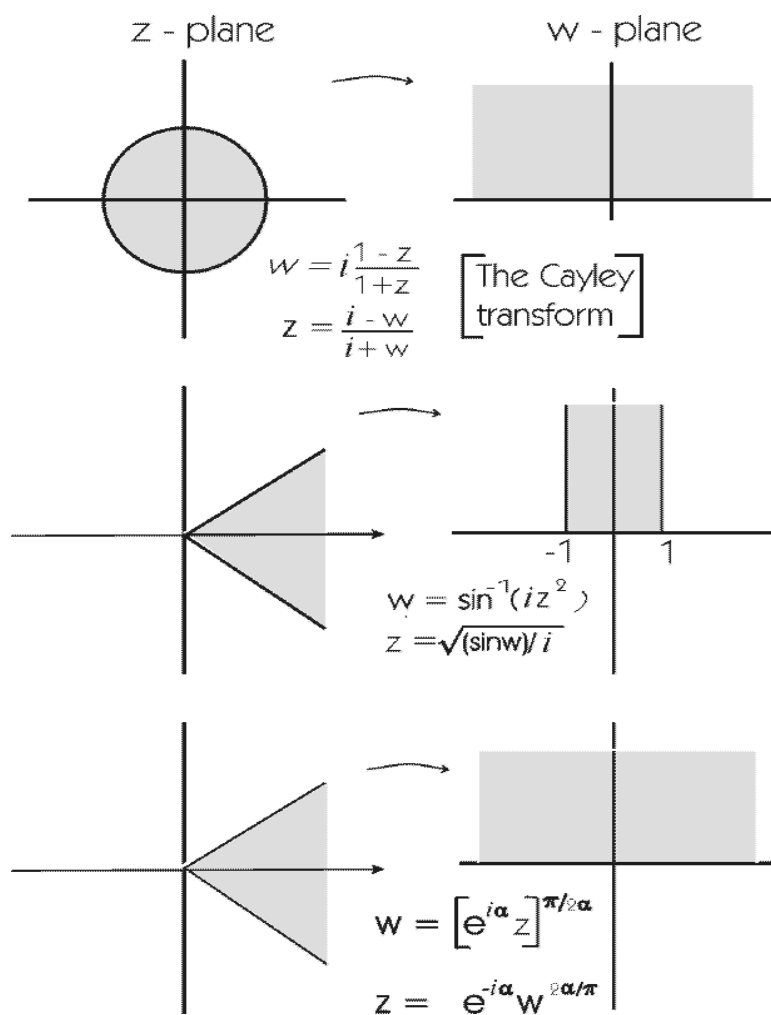


Figure 7.6: **(top)** The Cayley transform: A map of the disc to the upper half-plane; **(middle)** map of a wedge to a half-strip; **(bottom)** map of a wedge to the upper half-plane.

Figure 7.6 gives maps of the disc and the quarter-plane.

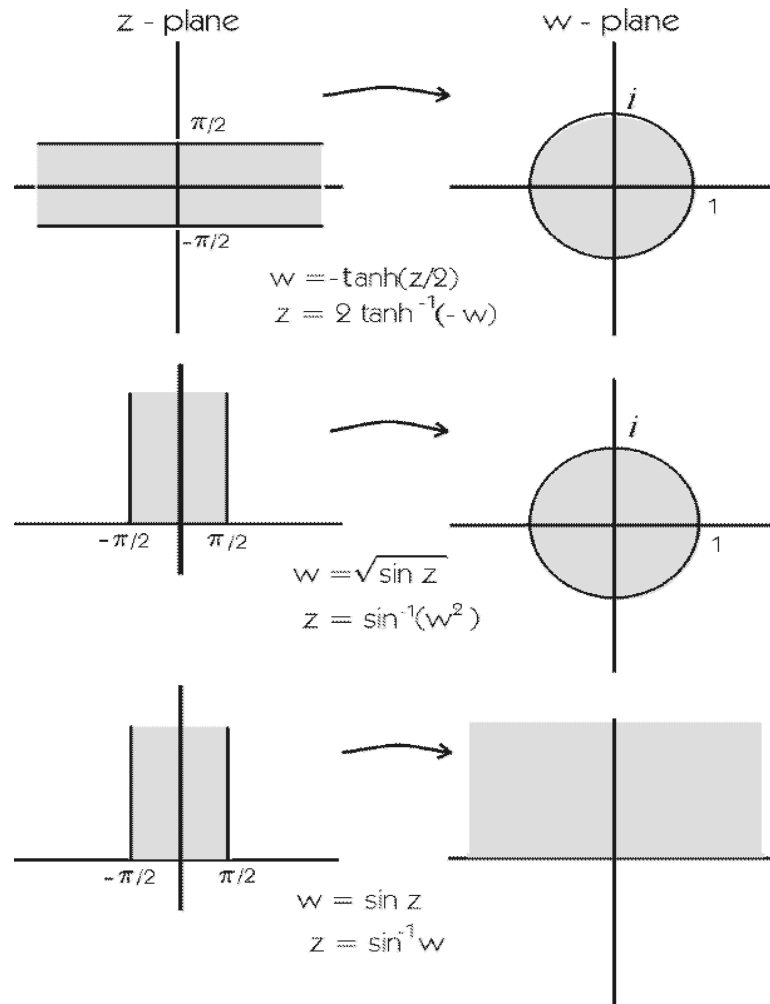


Figure 7.7: **(top)** Map of a strip to the disc; **(middle)** map of a half-strip to the disc; **(bottom)** map of a half-strip to the upper half-plane.

Figure 7.7 gives mappings of strips and half-strips.

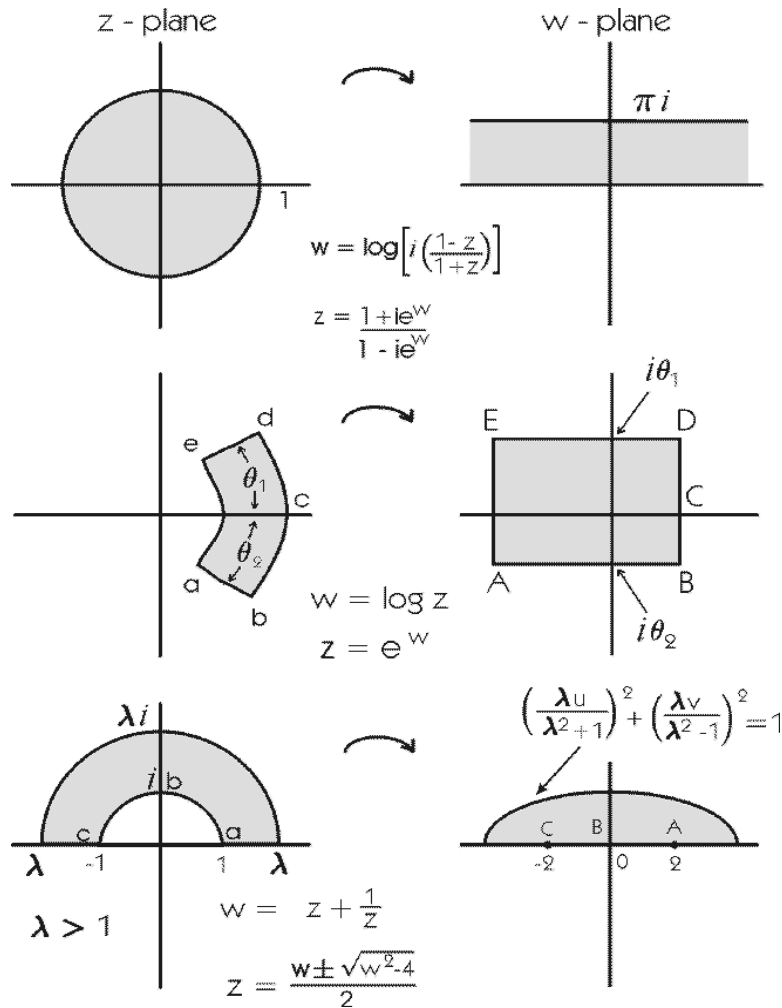


Figure 7.8: **(top)** Map of the disc to a strip; **(middle)** map of an annular sector to the interior of a rectangle; **(bottom)** map of a half-annulus to the interior of a half-ellipse.

Figure 7.8 gives maps of the disc and of certain annular regions.

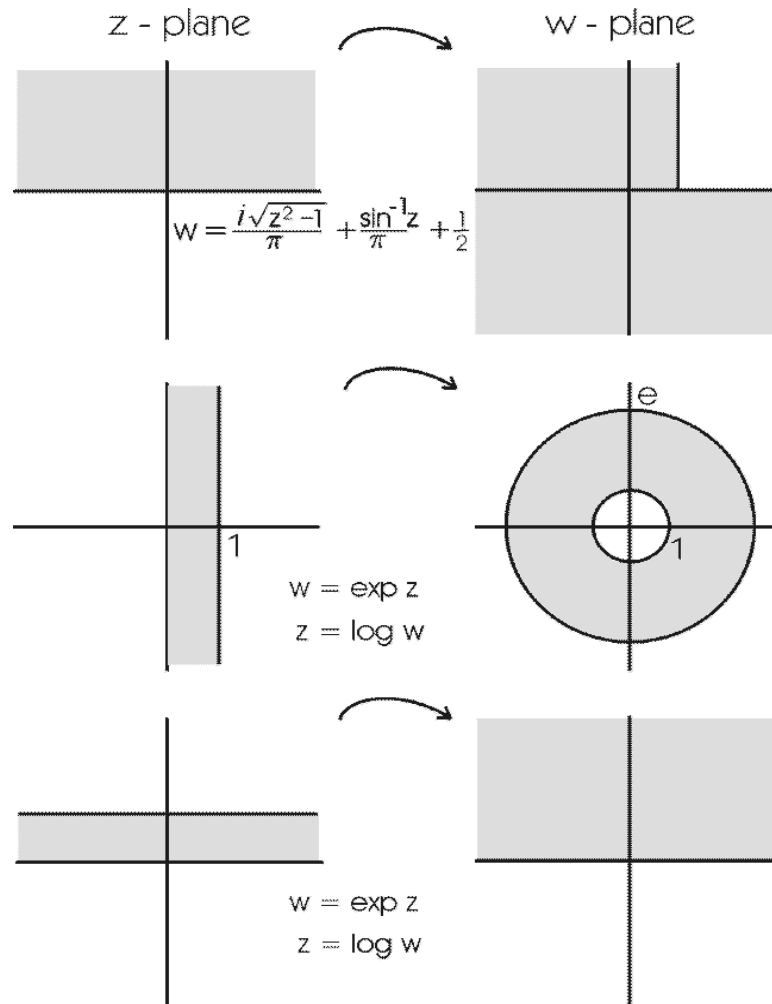


Figure 7.9: **(top)** Map of the upper half-plane to a 3/4-plane; **(middle)** map of a strip to an annulus; **(bottom)** map of a strip to the upper half-plane.

Figure 7.9 exhibits mappings of the upper half-plane and of certain strips.

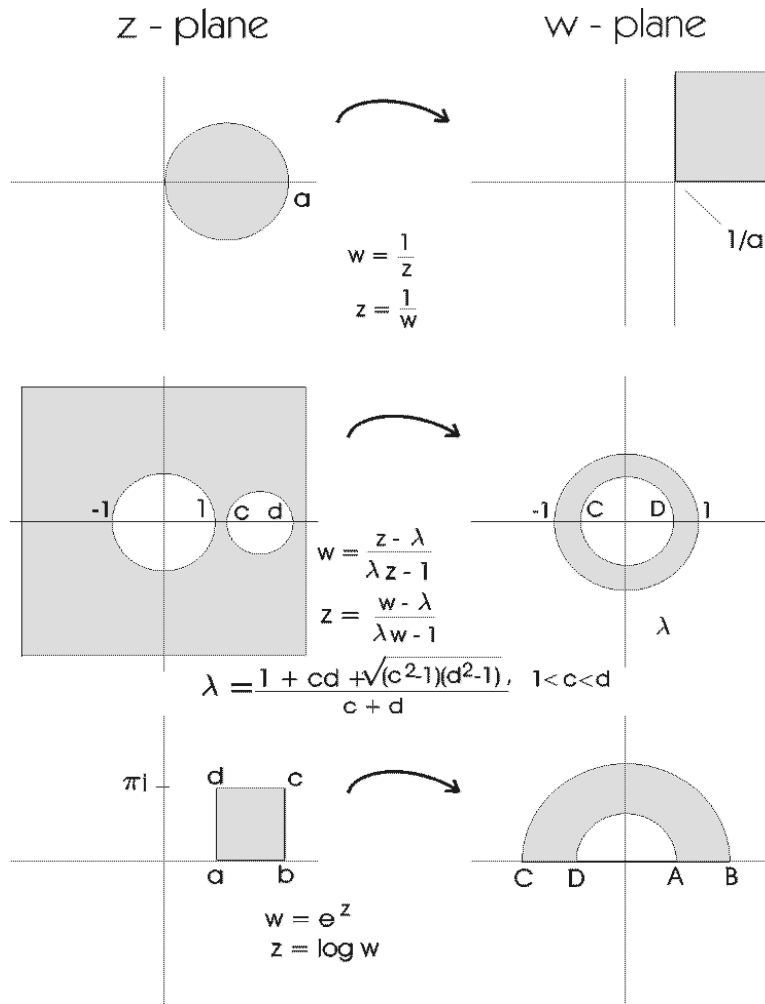


Figure 7.10: **(top)** Map of a disc to a quadrant; **(middle)** map of the complement of two discs to an annulus; **(bottom)** map of the interior of a rectangle to a half-annulus.

Figure 7.10 shows conformal maps of a disc, the complement of two discs, and a rectangle.

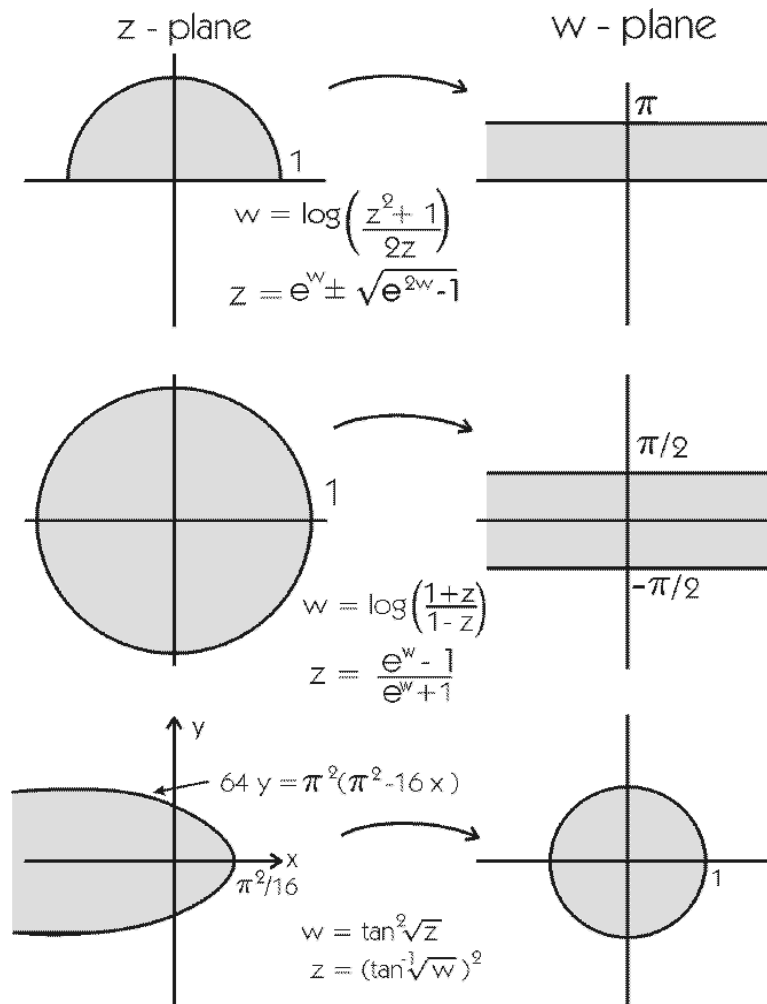


Figure 7.11: **(top)** Map of a half-disc to a strip; **(middle)** map of a disc to a strip; **(bottom)** map of the inside of a parabola to a disc.

Figure 7.11 gives maps of the half-disc, the disc, and the inside of a parabola.

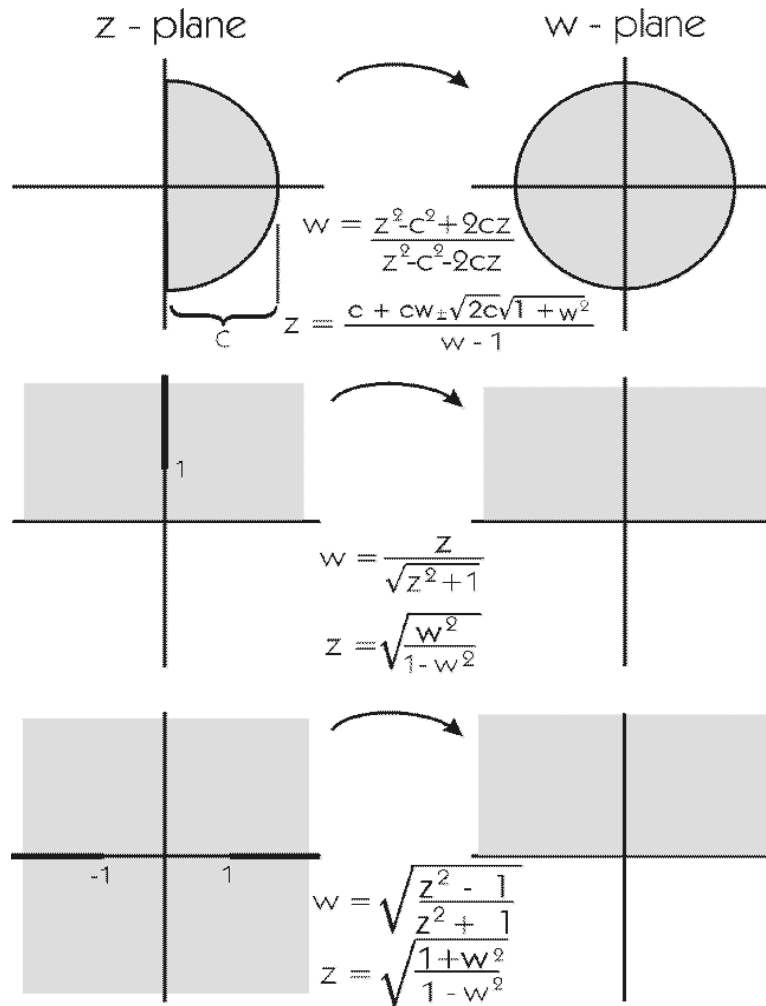


Figure 7.12: **(top)** Map of a half-disc to a disc; **(middle)** map of the slotted upper half-plane to upper half-plane; **(bottom)** map of the double-slotted plane to the upper half-plane.

Figure 7.12 shows maps of the half-disc, the slotted upper half-plane, and the double-slotted plane.

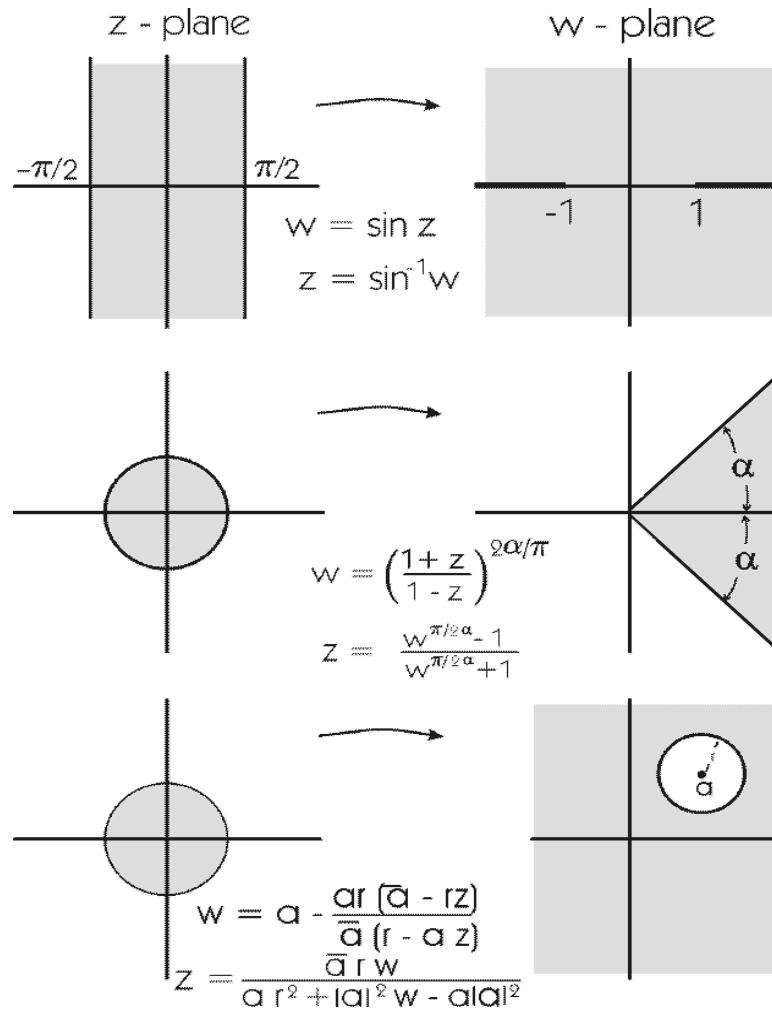


Figure 7.13: **(top)** Map of a strip to the double-sliced plane; **(middle)** map of the disc to a wedge; **(bottom)** map of a disc to the complement of a disc.

Figure 7.13 exhibits maps of the strip and the disc.

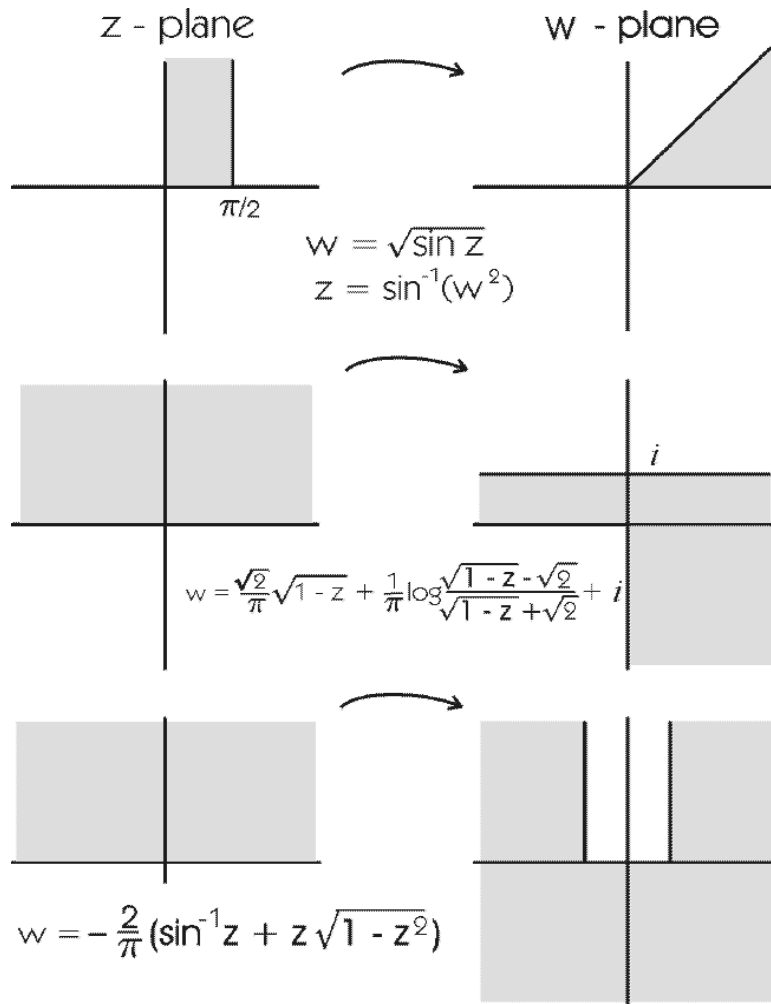


Figure 7.14: **(top)** Map of a half-strip to a half-quadrant; **(middle)** map of the upper half-plane to a right-angle region; **(bottom)** map of the upper half-plane to the plane less a half-strip.

Figure 7.14 gives maps of the half-strip and the half-plane.

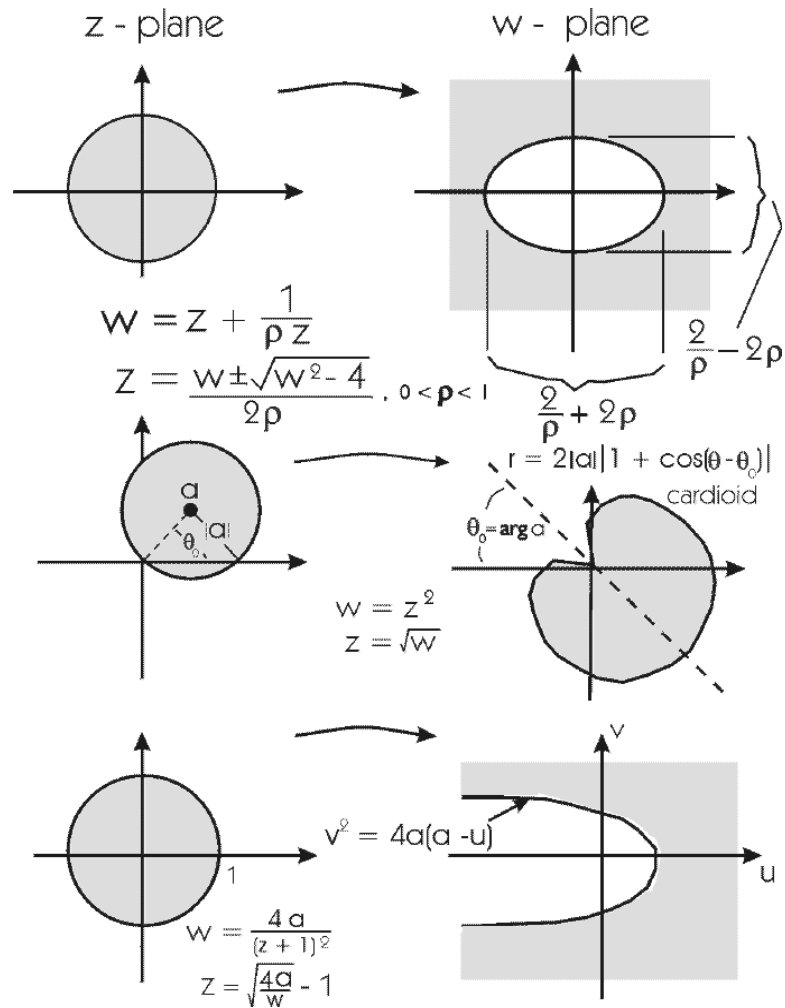


Figure 7.15: **(top)** Map of a disc to the complement of an ellipse; **(middle)** map of a disc to the interior of a cardioid; **(bottom)** map of a disc to the region outside a parabola.

Figure 7.15 shows maps of the disc.

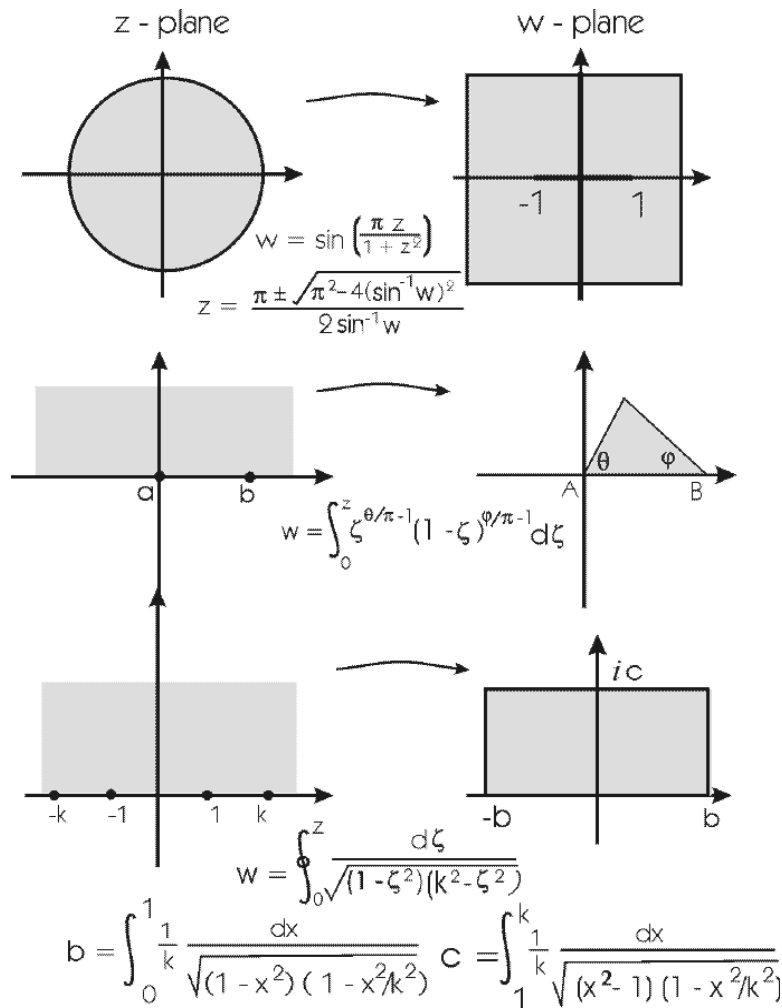
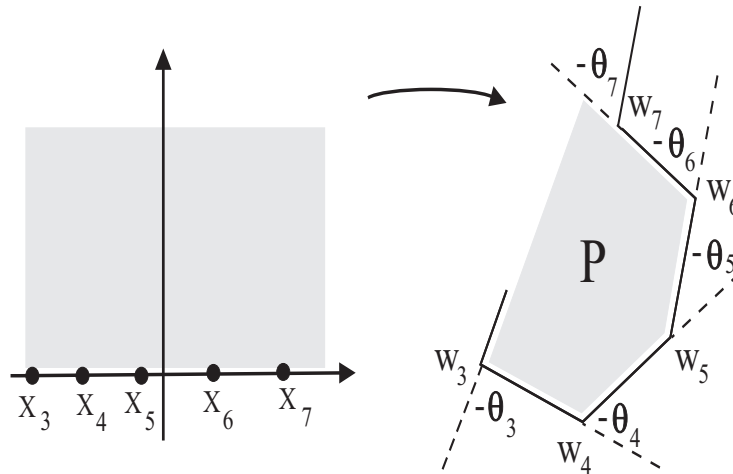


Figure 7.16: **(top)** Map of the disc to the slotted plane; **(middle)** map of the upper half-plane to the interior of a triangle; **(bottom)** map of the upper half-plane to the interior of a rectangle.

Figure 7.16 exhibits maps of the disc and the half-plane.



Only three of these points can be chosen at random. The rest are determined by the “geometry of P.”

$$w = f(z) = A \int_0^z \frac{dz}{(z-x_3)^{\theta_3/\pi} (z-x_4)^{\theta_4/\pi} \dots (z-x_{n-1})^{\theta_{n-1}/\pi}}$$

$$f(x_1) = w_1, f(x_2) = w_2, f(x_3) = w_3 \dots f(x_n) = w_n$$

Figure 7.17: The Schwarz-Christoffel formula.

Figure 7.17 illustrates the Schwarz-Christoffel formula.

Chapter 8

Applications that Depend on Conformal Mapping

8.1 Conformal Mapping

8.1.1 The Utility of Conformal Mappings

Part of the utility of conformal mappings is that they can be used to transform a problem on a given domain V to another domain U (see also Sections 7.1.1). Often we take U to be a standard domain such as the disc

$$D = \{z \in \mathbb{C} : |z| < 1\} \quad (8.1)$$

or the upper half-plane

$$\mathcal{U} = \{z \in \mathbb{C} : \text{Im } z > 0\}. \quad (8.2)$$

Particularly in the study of partial differential equations, it is important to have an *explicit* conformal mapping between the two domains.

Section 7.6 presented a concordance of commonly used conformal mappings. The reader will find that, even in cases where the precise mapping that he/she seeks has not been listed, he/she can (much as with a table of integrals) combine several of the given mappings to produce the results that are sought. It is also the case that the techniques presented here can be modified to suit a variety of different situations.

The references [KOB], [CCP], and [NEH] give more comprehensive lists of conformal mappings.

8.2 Application of Conformal Mapping to the Dirichlet Problem

8.2.1 The Dirichlet Problem

Let $\Omega \subseteq \mathbb{C}$ be a domain whose boundary consists of finitely many smooth curves. The *Dirichlet problem* (see Sections 8.2, 9.3, and 11.1), which is a mathematical problem of interest in its own right, is the boundary value problem

$$\begin{aligned}\Delta u &= 0 && \text{on } \Omega \\ u &= f && \text{on } \partial\Omega.\end{aligned}\tag{8.3}$$

Here Δ is the Laplace operator which we studied in Section 2.2.1.

The way to think about this problem is as follows: a data function f on the boundary of the domain is given. To solve the corresponding Dirichlet problem, one seeks a continuous function u on the closure of U (that is, the union of U and its boundary) such that u is harmonic on Ω and agrees with f on the boundary. We shall now describe three distinct physical situations that are mathematically modeled by the Dirichlet problem.

8.2.2 Physical Motivation for the Dirichlet Problem

I. Heat Diffusion: Imagine that Ω is a thin plate of heat-conducting metal. The shape of Ω is arbitrary (not necessarily a rectangle). See Figure 8.1. A function $u(x, y)$ describes the temperature at each point (x, y) in Ω . It is a standard situation in engineering or physics to consider idealized heat sources or sinks that maintain specified (fixed) values of u on certain parts of the boundary; other parts of the boundary are to be thermally insulated. One wants to find the steady state heat distribution on Ω (that is, as $t \rightarrow +\infty$) that is determined by the given boundary conditions. If we let f denote the temperature specified on the boundary, then it turns out that the solution of the Dirichlet problem (8.3) is the function that describes the steady state heat distribution (see [COH], [KRA1], [KRA4], [BRC, p. 300], and references therein for a derivation of this mathematical model for heat distribution).

We will present below some specific examples of heat diffusion problems that illustrate the mathematical model that we have discussed here, and we will show how conformal mapping can be used in aid of the solutions of the

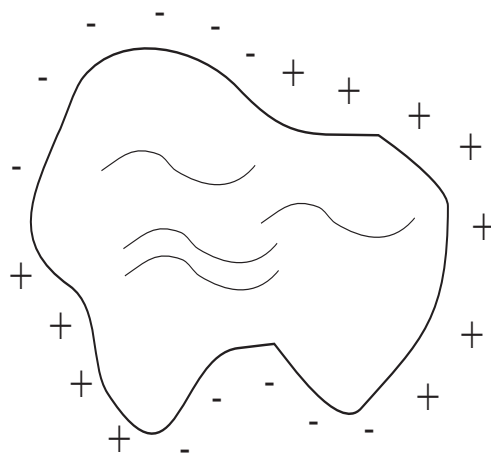


Figure 8.1: Heat distribution on the edge of a metal plate.

problems.

II. Electrostatic Potential: Now we describe a situation in electrostatics that is modeled by the boundary value problem (8.3).

Imagine a long, hollow cylinder made of a thin sheet of some conducting material, such as copper. Split the cylinder lengthwise into two equal pieces (Figure 8.2). Separate the two pieces with strips of insulating material (Figure 8.3). Now ground the upper of the two semi-cylindrical pieces to potential zero, and keep the lower piece at some nonzero fixed potential. For simplicity in the present discussion, let us say that this last fixed potential is 1. In the present situation, x , y , and z are real coordinates in Euclidean three-dimensional space—just as in calculus. In particular, z is *not* a complex variable.

Note that, in the figures, the axis of the cylinder is the z -axis. Consider a slice of this cylindrical picture which is taken by setting z equal to a small constant (we want to stay away from the ends of the cylinder, where the analysis will be a bit different).

Once we have fixed a value of z , then we may study the electrostatic potential $V(x, y)$, $x^2 + y^2 < 1$, at a point inside the cylinder. Observe that $V = 0$ on the “upper” half of the circle ($y > 0$) and $V = 1$ on the “lower”

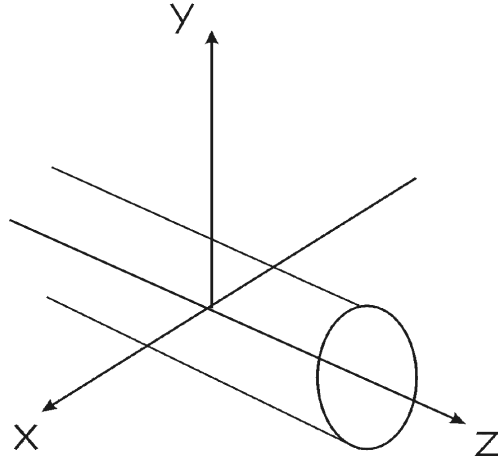


Figure 8.2: Electrostatic potential illustrated with a split cylinder.

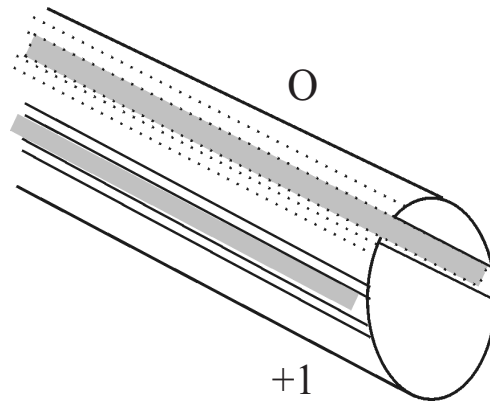


Figure 8.3: The cylindrical halves separated with insulating material.

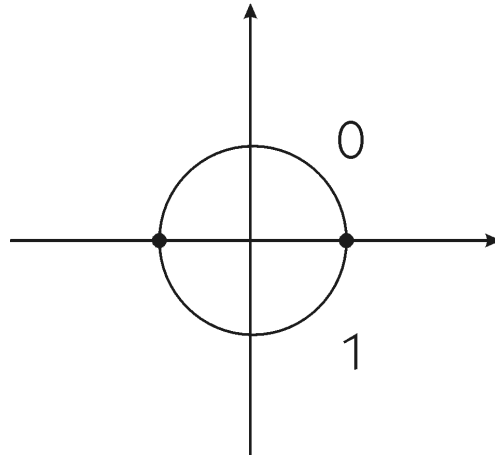


Figure 8.4: Distribution of the electrical potential.

half of the circle ($y < 0$)—see Figure 8.4. Physical analysis (see [BCH, p. 310]) shows that this is another Dirichlet problem, as in (8.3). We wish to find a harmonic function V on the disc $\{(x, y) : x^2 + y^2 \leq 1\}$ which agrees with the given potentials on the boundary.

Conformal mapping can be used as an aid in solving the problem posed here, and we shall discuss its solution below.

III. Incompressible Fluid Flow: For the mathematical model considered here, we consider a two-dimensional flow of a fluid that is

- incompressible
- irrotational
- free from viscosity

The first of these stipulations means that the fluid is of constant density, the second means that the curl is zero, and the third means that the fluid flows freely.

Identifying a point (a, b) in the $x - y$ plane with the complex number $a + ib$ as usual, we let

$$V(x, y) = p(x, y) + iq(x, y) \quad (8.4)$$

represent the velocity vector of our fluid flow at a point (x, y) . We assume that the fluid flow has no sources or sinks; and we hypothesize that p and q are C^1 , or once continuously differentiable (see Section 2.1.1).

The *circulation* of the fluid along any curve γ is the line integral

$$\int_{\gamma} V_T(x, y) \, d\mathbf{r}. \quad (8.5)$$

Here V_T represents the tangential component of the velocity along the curve γ and σ denotes arc length. We know from advanced calculus that the circulation can be written as

$$\int_{\gamma} p(x, y) \, dx + \int_{\gamma} q(x, y) \, dy. \quad (8.6)$$

We assume here that γ is a positively (counterclockwise) oriented simple, closed curve that lies in a simply connected region D of the flow.

Now Green's theorem allows us to rewrite this last expression for the circulation as

$$\iint_R [q_x(x, y) - p_y(x, y)] \, dA. \quad (8.7)$$

Here the subscripts x and y represent partial derivatives, R is the region surrounded by γ , and dA is the element of area. In summary,

$$\int_{\gamma} V_T(x, y) \, d\mathbf{r} = \iint_R [q_x(x, y) - p_y(x, y)] \, dA. \quad (8.8)$$

Let us specialize to the case that γ is a circle of radius r with center $p_0 = (x_0, y_0)$. Call the disc-shaped region inside the circle R . Then the mean angular speed of the flow along γ is

$$\frac{1}{\pi r^2} \iint_R \frac{1}{2} [q_x(x, y) - p_y(x, y)] \, dA. \quad (8.9)$$

This expression also happens to represent the average of the function

$$\omega(x, y) = \frac{1}{2} [q_x(x, y) - p_y(x, y)] \quad (8.10)$$

over R . Since ω is continuous, the limit as $r \rightarrow 0$ of (8.9) is just $\omega(p_0)$. It is appropriate to call ω the *rotation* of the fluid, since it is the limit at the

point p_0 of the angular speed of a circular element of the fluid at the point p_0 . Since our fluid is irrotational, we set $\omega = 0$. Thus we know that

$$p_y = q_x \quad (8.11)$$

in the region D where the flow takes place. Multidimensional calculus then tells us that the flow is path-independent: If $X = (x, y)$ is any point in the region and γ is any path joining p_0 to X , then the integral

$$\int_{\gamma} p(s, t) ds + \int_{\gamma} q(s, t) dt \quad (8.12)$$

is independent of the choice of γ . As a result, the function

$$\varphi(x, y) = \int_{p_0}^X p(s, t) ds + q(s, t) dt \quad (8.13)$$

is well-defined on D , where the integral is understood to take place along *any* curve connecting p_0 to X . Differentiating the equation that defines φ , we find that

$$\frac{\partial}{\partial x} \varphi(x, y) = p(x, y) \quad \text{and} \quad \frac{\partial}{\partial y} \varphi(x, y) = q(x, y). \quad (8.14)$$

We call φ a *potential function* for the flow. To summarize, we know that $\nabla \varphi = (p, q)$.

The natural physical requirement that the incompressible fluid enter or leave an element of volume only by flowing through the boundary of that element (no sources or sinks) entails the mathematical condition that φ be harmonic. Thus

$$\varphi_{xx} + \varphi_{yy} = 0 \quad (8.15)$$

on D . In conclusion, studying a fluid flow with specified boundary data will entail solving the boundary value problem (8.3).

Note that Exercise 13 gives a detailed mathematical model, due to Daniel Bernoulli, for fluid flow.

8.3 Physical Examples Solved by Means of Conformal Mapping

In this section we give a concrete illustration of the solution of each of the physical problems described in the last section.

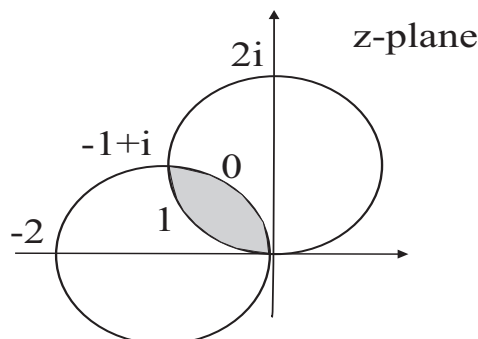


Figure 8.5: A lens-shaped piece of heat-conducting metal.

8.3.1 Steady State Heat Distribution on a Lens-Shaped Region

EXAMPLE 52 Imagine a lens-shaped sheet of heat-conducting metal as in Figure 8.5. Suppose that the initial distribution of heat is specified to be 1 on the lower boundary of the lens and 0 on the upper boundary of the lens (as illustrated in the figure). Determine the steady state heat distribution. \square

Solution: Our strategy is to use a conformal mapping to transfer the problem to a new domain on which it is easier to work. We let $z = x + iy$ denote the variable in the lens-shaped region and $w = u + iv$ denote the variable in the new region (which will be an angular region).

In fact let us construct the conformal mapping with our bare hands. If we arrange for the mapping to be linear fractional and to send the origin to the origin and the point $-1 + i$ to infinity, then (since linear fractional transformations send lines and circles to lines and circles), the images of the two circular arcs will both be lines. Let us in fact examine the mapping

$$w = f(z) = \frac{-z}{z - (-1 + i)}. \quad (8.16)$$

(The minus sign in the numerator is introduced for convenience.)

We see that $f(0) = 0$, $f(2i) = -1 - i$, and $f(-2) = -1 + i$. And of course $f(-1 + i) = \infty$. Using conformality (preservation of right angles),

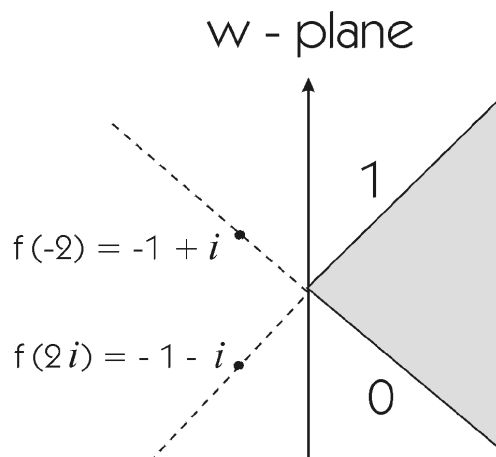


Figure 8.6: The angular region in the w -plane that is the image of the lens-shaped region in the z -plane.

we conclude that the image of the lens-shaped region in the z -plane is the angular region in the w -plane depicted in Figure 8.6. The figure also shows on which part of the boundary the function we seek is to have value 0 and on which part it is to have value 1. It is easy to write down a harmonic function φ of the w variable that satisfies the required boundary conditions:

$$\varphi(w) = \frac{2}{\pi} \left(\arg w + \frac{\pi}{4} \right) \quad (8.17)$$

will certainly do the job if we demand that $-\pi < \arg w < \pi$. But then the function

$$u(z) = \varphi \circ f(z) \quad (8.18)$$

is a harmonic function on the lens-shaped domain in the z -plane that has the requisite boundary values (we use of course the fact that the composition of a harmonic function with a holomorphic function is still harmonic).

In other words, the solution to the problem originally posed on the lens-shaped domain in the z -plane is

$$u(z) = \frac{2}{\pi} \cdot \arg \left(\frac{-z}{z - (-1 + i)} \right) + \frac{1}{2}. \quad (8.19)$$

This can also be written as

$$u(z) = \frac{2}{\pi} \cdot \tan^{-1} \left[\frac{-y - x}{-x(x + 1) - y(y - 1)} \right] + \frac{1}{2}. \quad (8.20)$$

□

Exercise for the Reader: Verify in detail that formulas (8.19) and (8.20) are equivalent.

8.3.2 Electrostatics on a Disc

EXAMPLE 53 We now analyze the problem that was set up in part II of Section 8.2. We do so by conformally mapping the unit disc (in the z plane) to the upper half-plane (in the w plane) by way of the mapping

$$w = f(z) = i \cdot \frac{1 - z}{1 + z}. \quad (8.21)$$

See Figure 8.7. Observe that this conformal mapping takes the upper half of the unit circle to the positive real axis, the lower half of the unit circle to the negative real axis, and the point 1 to the origin (and the point -1 to ∞).

Thus we are led to consider the following boundary value problem on the upper half-plane in the w variable: we seek a harmonic function on the upper half-plane with boundary value 0 on the positive real axis and boundary value 1 on the negative real axis. Certainly the function

$$\varphi(w) = \frac{1}{\pi} \arg w \quad (8.22)$$

does the job, if we assume that $0 \leq \arg w < 2\pi$. We pull this solution back to the disc by way of the mapping f :

$$u = \varphi \circ f. \quad (8.23)$$

This function u is harmonic on the unit disc, has boundary value 0 on the upper half of the circle, and boundary value 1 on the lower half of the circle.

Our solution may be written more explicitly as

$$u(z) = \frac{1}{\pi} \arg \left[i \cdot \frac{1 - z}{1 + z} \right] \quad (8.24)$$

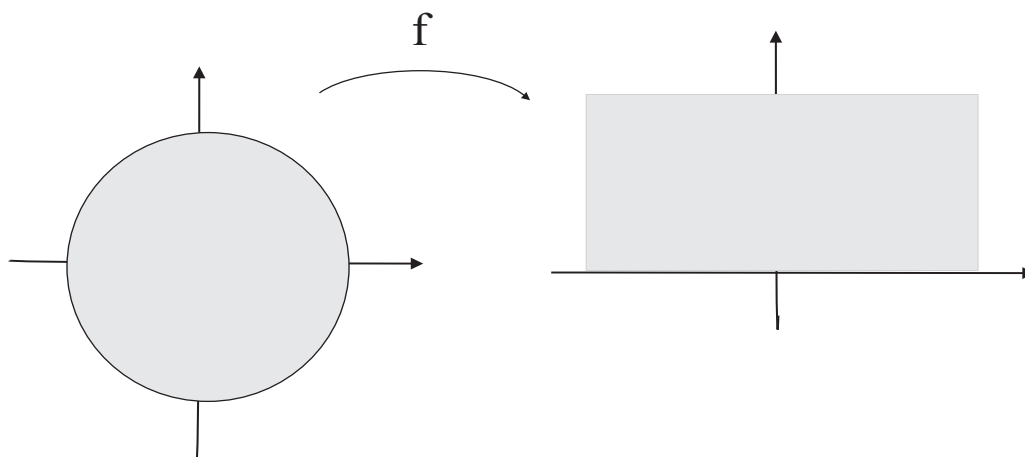


Figure 8.7: Conformal map of the disc to the upper half-plane.

or as

$$u(z) = \frac{1}{\pi} \tan^{-1} \left[\frac{1 - x^2 - y^2}{2y} \right]. \quad (8.25)$$

Of course for this last form of the solution to make sense, we must take $0 \leq \arctan t \leq \pi$ and we must note that

$$\lim_{\substack{t \rightarrow 0 \\ t > 0}} \arctan t = 0 \quad \text{and} \quad \lim_{\substack{t \rightarrow 0 \\ t < 0}} \arctan t = \pi. \quad (8.26)$$

□

8.3.3 Incompressible Fluid Flow around a Post

EXAMPLE 54 We study the classic problem of the flow of an incompressible fluid around a cylindrical post.

Recall the potential function φ from the end of the discussion in III of Section 8.2. If

$$V = p + iq \quad (8.27)$$

is the velocity vector, then we may write

$$V = \varphi_x + i\varphi_y = \text{grad } \varphi. \quad (8.28)$$

Since φ is harmonic, we may select a conjugate harmonic function ψ (see Section 2.2.2) for φ . Because of the Cauchy-Riemann equations, the velocity vector will be tangent to any curve $\psi(x, y) = \text{constant}$. The function ψ is called the *stream function* for the flow. The curves $\psi(x, y) = \text{constant}$ are called *streamlines* of the fluid flow. We call the holomorphic function

$$H(x + iy) = \varphi(x, y) + i\psi(x, y) \quad (8.29)$$

the *complex potential* of the fluid flow.

Using the Cauchy-Riemann equations twice, we can write $H'(z)$ as

$$H'(z) = \varphi_x(x, y) + i\psi_x(x, y) \quad (8.30)$$

or

$$H'(z) = \varphi_x(x, y) - i\varphi_y(x, y). \quad (8.31)$$

Thus formula (8.28) for the velocity becomes

$$V = \overline{H'(z)}. \quad (8.32)$$

As a result,

$$\text{speed} = |V| = |\overline{H'(z)}| = |H'(z)|. \quad (8.33)$$

The analysis we have just described means that, in order to solve an incompressible fluid flow problem, we need to find the complex potential function H .

Now consider an incompressible fluid flow with a circular obstacle as depicted in Figure 8.8. The flow is from left to right. Far away from the obstacle, the flow is very nearly along horizontal lines parallel to the x -axis. But near to the obstacle the flow will be diverted. Our job is to determine analytically just how that diversion takes place.

We consider the circular obstacle to be given by the equation $x^2 + y^2 = 1$. Elementary symmetry considerations allow us to restrict attention to the flow in the upper half-plane. See Figure 8.9.

The boundary of the region W of the flow (Figure 8.9) is mapped to the boundary of the upper half-plane U in the w variable (this boundary is just the u -axis) by the conformal mapping

$$w = f(z) = z + \frac{1}{z}. \quad (8.34)$$

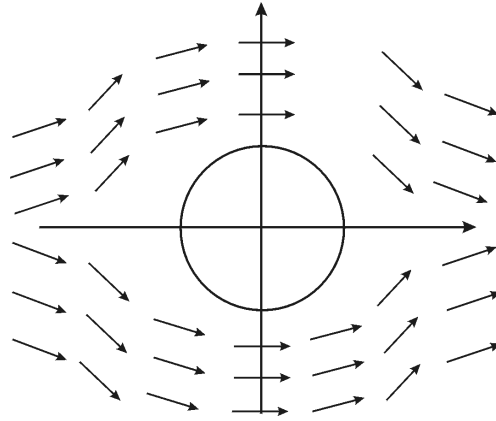


Figure 8.8: Incompressible fluid flow with a circular obstacle.

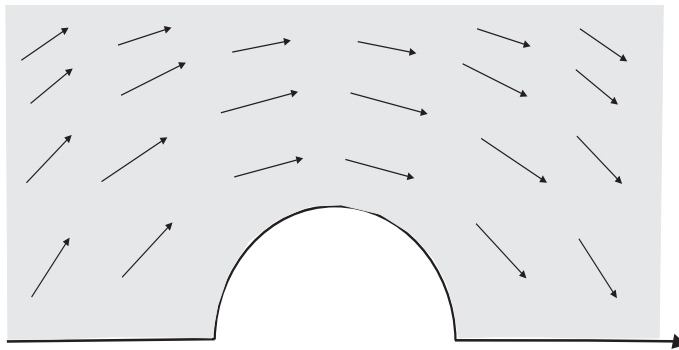


Figure 8.9: Restriction of attention to the flow in the upper half-plane.

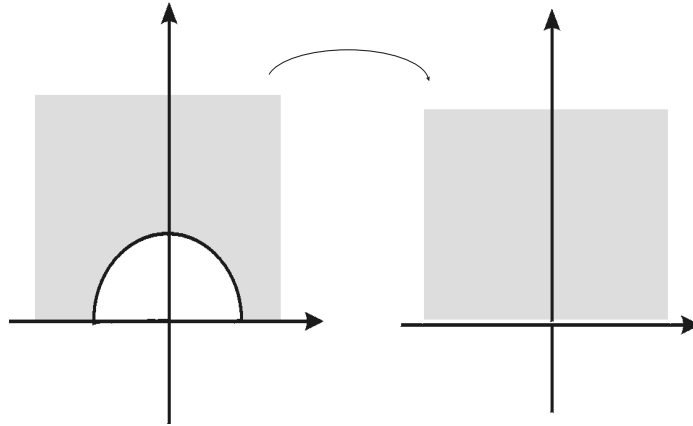


Figure 8.10: Conformal mapping of the region of the flow to the upper half-plane.

In fact, notice that

$$\begin{aligned} -1 &\mapsto -2 \\ 1 &\mapsto 2 \\ i &\mapsto 0, \end{aligned}$$

so it follows that the circular arc goes to the segment $[-2, 2]$. Of course the ray $[1, \infty)$ is mapped to the ray $[2, \infty)$ and the ray $(-\infty, -1]$ is mapped to the ray $(-\infty, -2]$. In sum, the boundary goes to the boundary.

And the region itself (shaded in Figure 8.9) is mapped to the upper half-plane in the w variable. The mapping is exhibited in Figure 8.10.

The complex potential for a uniform flow in the upper half-plane of the w variable is

$$G(w) = Aw, \tag{8.35}$$

where A is a positive constant. Composing this potential with the mapping f , we find that the corresponding potential on W is

$$H(z) = G \circ f(z) = A \cdot \left(z + \frac{1}{z} \right). \tag{8.36}$$

The velocity (referring to equation (8.32)) is then

$$V = \overline{H'(z)} = A \left(1 - \frac{1}{\bar{z}^2} \right). \quad (8.37)$$

Note that V approaches A as $|z|$ increases monotonically to infinity. We conclude that the flow is almost uniform, and parallel to the x -axis, at points that are far from the circular obstacle. Finally, observe that $V(\bar{z}) = \overline{V(z)}$, so that, by symmetry, formula (8.37) also represents the velocity of the flow in the lower half-plane.

According to equation (8.29), the stream function for our problem, written in polar coordinates, is just the imaginary part of H , or

$$\psi = A \left(r - \frac{1}{r} \right) \sin \theta. \quad (8.38)$$

The streamlines

$$A \left(r - \frac{1}{r} \right) \sin \theta = C \quad (8.39)$$

are symmetric with respect to the y -axis and have asymptotes parallel to the x -axis. When $C = 0$, then the streamline consists of the circle $r = 1$ and the parts of the x axis that lie outside the unit circle. \square

8.4 Numerical Techniques of Conformal Mapping

In practical applications, computer techniques for calculating conformal mappings have proved to be decisive. For instance, it is a standard technique to conformally map the complement of an airfoil (Figure 8.11) to the complement of a circle in order to study a boundary value problem on the complement. Of course the boundary of the airfoil is not given by any standard geometric curve (circle, parabola, ellipse, etc.), and the only hope of getting accurate information about the conformal mapping is by means of numerical analysis.

The literature on numerical techniques of conformal mapping is extensive. The reference [KYT] is a gateway to some of the standard references. Here we present only a brief sketch of some of the ideas.

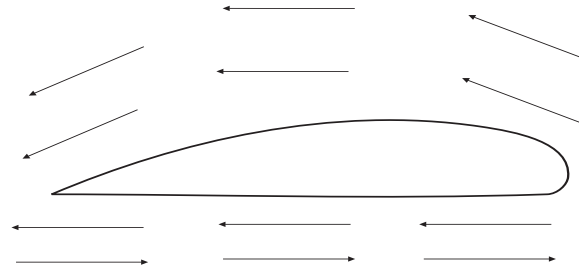


Figure 8.11: An airfoil.

8.4.1 Numerical Approximation of the Schwarz-Christoffel Mapping

Of course it is not very realistic or practical to think that we could come up with an explicit algorithm for mapping the disc or the upper half-plane to *any* simply connected region. A perhaps more realistic goal is to map the disc or upper half-plane to any polygon. The theory of Schwarz and Christoffel is a great aid in studying polygonal regions.

Most any region can be exhausted by polygons, so this gives a fairly broad class of regions that we can handle. Section 8.4.2 also discusses a method of treating an arbitrary smoothly bounded region by thinking of it as a polygon with infinitely many sides.

Let P be a polygon in the complex plane with vertices w_1, \dots, w_n . We wish to conformally map, by way of a mapping g , the upper half-plane \mathcal{U} to the interior of P —see Figure 8.12. The vertices w_1, \dots, w_{n-1} in the boundary of P will have preimages x_1, \dots, x_{n-1} under g in $\partial\mathcal{U}$. These latter points are called *prevertices*. It is standard to take $\pm\infty \in \partial\mathcal{U}$ to be the preimages of the last vertex w_n . Observe that, associated to each corner w_j , we have a “right-turn angle” θ_j . See Figure 8.13.

A conformal self-map of the unit disc is completely determined once the images of three boundary points are known. This fact is easily seen from the explicit formula for a conformal self-map of the disc that we derived in Section 7.2—there are clearly three degrees of freedom in the formula. Since the disc and the upper half-plane are conformally equivalent by way of the Cayley transform (Section 7.3.5), it follows that, in specifying the Schwarz-

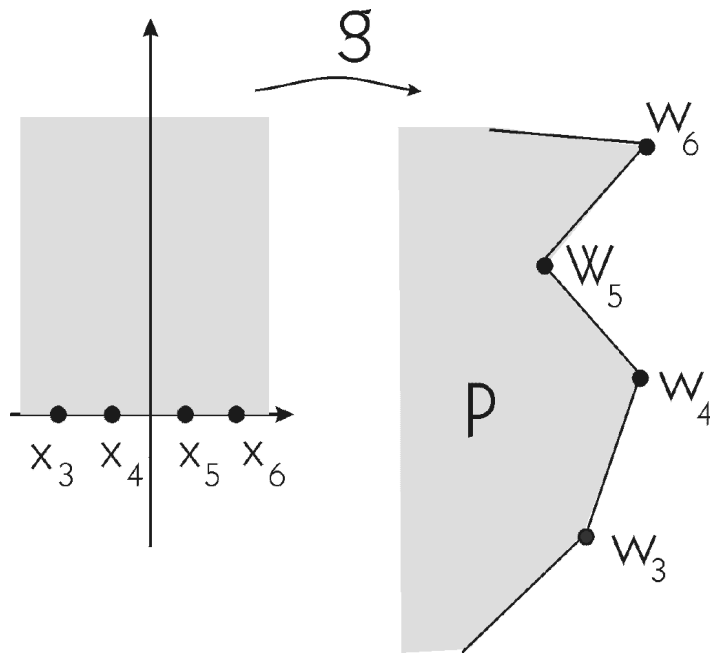


Figure 8.12: Mapping the upper half-plane to a polygonal region.

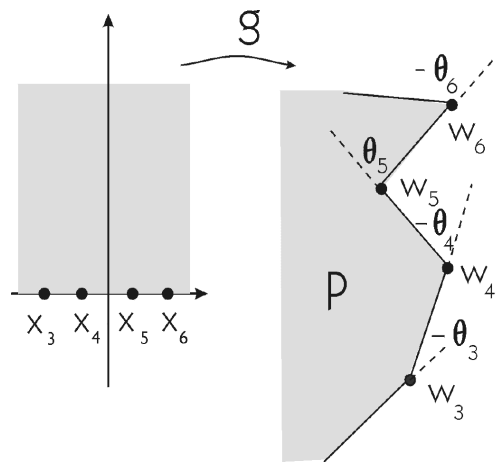


Figure 8.13: Vertices, prevertices, and right-turn angles.

Christoffel map, we may select three of the x_j 's arbitrarily.

We will take $x_1 = -1$, $x_2 = 0$, and $x_n = +\infty$. It remains to determine the other $n-3$ vertices (which may *not* be freely chosen). The Schwarz-Christoffel map has the form

$$A \oint d\zeta + B \quad (8.40)$$

(see Figure 8.14). The choice of A will determine the size of the image and the choice of B will determine the position. Thus we need to choose x_3, \dots, x_{n-1} so that the image mapping has the right *shape*.

Specifying that the image of the Schwarz-Christoffel map g has the pre-specified shape (that is, the shape of P) is equivalent to demanding that

$$\frac{|g(x_j) - g(x_{j-1})|}{|g(x_2) - g(x_1)|} = \frac{|w_j - w_{j-1}|}{|w_2 - w_1|}, \quad j = 3, 4, \dots, n-1. \quad (8.41)$$

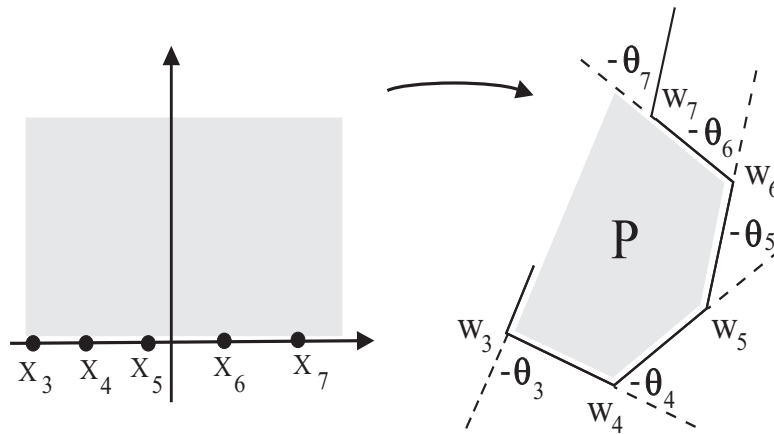
The theory of Schwarz-Christoffel guarantees that the angles in the image will be correct, and the $n-3$ equations exhibited force $n-2$ of the side lengths to have the correct proportions. With a little planar geometry, one sees that this information in turn completely determines the shape of the image of the mapping g .

Finding the correct prevertices for a Schwarz-Christoffel mapping problem is called the *Schwarz-Christoffel parameter problem*. The problem is resolved by solving the constrained system (as indicated in Figure 8.14) of $n-3$ nonlinear equations. The constraint is that $0 < x_3 < x_4 < \dots < x_{n-1} < \infty$. Unfortunately, standard numerical solution techniques (such as Newton's method and its variants) do not allow for constraints such as these. We can eliminate the constraints with a change of variable: Set

$$\tilde{x}_j = \log(x_j - x_{j-1}), \quad j = 3, 4, \dots, n-1.$$

The \tilde{x}_j s are arbitrary real numbers, with no constraints. The new system, expressed in terms of the variables $\tilde{x}_3, \tilde{x}_4, \dots, \tilde{x}_{n-1}$, can be solved using a suitable version of Newton's method. The necessary algorithm is available as part of `MatLab`, `Mathematica`, `Maple`, and also on most large scientific computer installations.

Once we have solved the Schwarz-Christoffel parameter problem, then we wish to calculate the actual conformal map. This entails calculating the



Only three of these points can be chosen at random. The rest are determined by the “geometry of P.”

$$w = f(z) = A \int_0^z \frac{dz}{(z-x_1)^{\theta_1/\pi} (z-x_2)^{\theta_2/\pi} \dots (z-x_{n-1})^{\theta_{n-1}/\pi}} + B$$

$$f(x_1) = w_1, f(x_2) = w_2, f(x_3) = w_3 \dots f(x_n) = w_n$$

Figure 8.14: Details of the Schwarz-Christoffel mapping.

Schwarz-Christoffel integral

$$\oint_0^z (\zeta - x_1)^{\theta_1/\pi} (\zeta - x_2)^{\theta_2/\pi} \cdots (\zeta - x_{n-1})^{\theta_{n-1}/\pi} d\zeta. \quad (8.42)$$

Even when P is a very simple polygon such as a triangle, we cannot expect to evaluate the integral (8.42) by hand. There are well-known numerical techniques for evaluating an integral $\int_a^b \varphi(t) dt$. Let us describe three of them: Fix a partition $a = t_0 \leq t_1 \leq \cdots \leq t_k = b$ of the interval of integration, which is such that each interval in the partition has the same length. Let $\Delta t = (b - a)/k$ denote that common length.

I. The Midpoint Rule Set $p_n = a + (n - 1/2)\Delta t$, $n = 1, \dots, k$. Then

$$\int_a^b \varphi(t) dt \approx \sum_{n=1}^k \varphi(p_n) \Delta t. \quad (8.43)$$

If φ is smooth, then the error in this calculation is of size k^{-2} .

II. The Trapezoid Rule In this methodology we take the points p_n at which φ is evaluated to be the interval endpoints. We have

$$\int_a^b \varphi(t) dt \approx \frac{\Delta t}{2} [\varphi(t_0) + 2\varphi(t_1) + 2\varphi(t_2) + \cdots + 2\varphi(t_{k-1}) + \varphi(t_k)]. \quad (8.44)$$

If φ is smooth, then the error in this calculation is of size k^{-3} .

III. Simpson's Rule In this methodology we use both the interval endpoints and the midpoints. We have

$$\int_a^b \varphi(t) dt \approx \frac{\Delta t}{6} \left\{ \varphi(t_0) + \varphi(t_k) + 2[\varphi(t_1) + \cdots + \varphi(t_{k-1})] + 4 \left[\varphi\left(\frac{t_0 + t_1}{2}\right) + \cdots + \varphi\left(\frac{t_{k-1} + t_k}{2}\right) \right] \right\}. \quad (8.45)$$

If φ is smooth, then the error in this calculation is of size k^{-4} .

More sophisticated techniques, such as the *Newton-Cotes formulas* and *Gaussian quadrature* give even more accurate approximations.

Unfortunately, the integrand in the Schwarz-Christoffel integral has singularities at the prevertices x_j . Thus we must use a variant of the above-described numerical integration techniques with the partition points and with weights chosen so as to compensate for the singularities. These ideas are encapsulated in the method of *Gauss-Jacobi quadrature*.

Finally, it is often the case that the prevertices are very close together. This extreme proximity can work against the compensating properties of Gauss-Jacobi quadrature. The method of *compound Gauss-Jacobi quadrature* mandates that difficult intervals be heavily subdivided near the endpoints. This method results in a successful calculation of the Schwarz-Christoffel mapping.

8.4.2 Numerical Approximation to a Mapping onto a Smooth Domain

One can construct a numerical approximation to a conformal mapping of the upper half-plane \mathcal{U} onto a smoothly bounded domain Ω with boundary curve C by thinking of C as a polygon with infinitely many corners w_n , each with infinitesimal turning angle θ_n .

From the Schwarz-Christoffel formula for the mapping g that we discussed in Section 8.4.1, we know that

$$\begin{aligned} g'(z) &= A(z - x_1)^{\theta_1/\pi} (z - x_2)^{\theta_2/\pi} (z - x_{n-1})^{\theta_{n-1}/\pi} \\ &= A \exp \left[\frac{1}{\pi} \sum_{j=1}^{n-1} \theta_j \log(z - x_j) \right]. \end{aligned} \quad (8.46)$$

As $n \rightarrow +\infty$, it is natural to think of the sum as converging to an integral. So we have derived the formula

$$g'(z) = A \exp \left[\frac{1}{\pi} \int_{-\infty}^{\infty} \theta(x) \log(z - x) dx \right]. \quad (8.47)$$

Here θ is a function that describes the turning of the curve C per unit length along the x -axis. Integrating, we find that

$$g(z) = A \int_0^z \exp \left[\frac{1}{\pi} \int_{-\infty}^{\infty} \theta(x) \log(z - x) dx \right] + B. \quad (8.48)$$

Of course the discussion here has only been a sketch of some of the key ideas associated with numerical conformal mapping. The reference [SASN, pp. 430–443] gives a more discursive discussion, with detailed examples. The reference [SASN] also offers a further guide to the literature.

Exercises

1. Find a conformal map from the first quadrant $Q = \{x + iy : x > 0, y > 0\}$ to the unit disc.
2. Consider the fluid flow around a round post as discussed in the text. What happens to the flow when the radius of the post gets larger? What happens to the flow when the radius of the post gets smaller? Discuss.
3. Explain why, if the initial heat distribution on the boundary of the unit disc is not identically zero, then the steady-state heat distribution across the disc cannot be identically zero. Give an explanation in terms of physical principles and an explanation in terms of mathematical ideas.
4. Use the Schwarz-Christoffel transformation to say something about the solution of the Dirichlet problem on a square of side 1 with sides parallel to the coordinate axes and with data equal to 1 on the horizontal sides and equal to 0 on the vertical sides.
5. Imagine heat diffusion on the unit disc with initial data equal to $\sin \theta$ at the point $e^{i\theta}$ on the boundary of the disc. What can you say about the steady state heat distribution?
6. Answer Exercise 5 with $\sin \theta$ replaced by θ .
7. Answer Exercise 5 with $\sin \theta$ replaced by $\cos 5\theta$.
8. Discuss how the electrostatics problem in the text changes as the radius of the cylinder changes.
9. Suppose that the initial heat distribution given on the boundary of the unit disc is a smooth function—infinately differentiable. Then we

might hope that the resulting heat distribution across the disc will extend smoothly to the boundary. Explain this idea in physical terms.

10. Explain why, if the initial heat distribution on the boundary of the unit disc is positive, then we would expect the steady-state temperature at every point of the disc to be positive. Your answer may be in either physical terms or mathematical terms.
11. Let f be a given continuous function on the boundary of the unit disc. Write a `MatLab` utility that will find the value of the solution of the Dirichlet problem with boundary data f at a given interior point $z = x + iy$.
12. Refer to Exercise 11. Write a `MatLab` utility that will find the location of the absolute maximum and the absolute minimum of the function that is the solution of the Dirichlet problem with boundary data f .
13. There are a number of different mathematical models for fluid flow. One of the classic ones is known as *Bernoulli's law* (Daniel Bernoulli (1700–1782)). It states that

$$P + \frac{1}{2}\rho v^2 + \rho gh = C ,$$

where C is a physical constant. In this equation, P is the static pressure of the fluid (measured in Newtons per square meter), ρ is the fluid density (measured in kilograms per square meter), v is the velocity of the fluid flow (measured in meters per second), and h is the height above a reference surface. Of course g is the usual gravitational constant. The second term on the left is sometimes referred to as the *dynamic pressure*. It may be noted that Bernoulli's equation describes the flow of many different types of fluids. As an example, it can be used to analyze why an airfoil works.

Complete the following outline to derive Bernoulli's law:

Picture an ideal fluid flowing down a pipe at a steady rate. Let W denote the work done by applying a pressure P over an area A producing an offset of $\Delta\ell$ (or a volume change of ΔV). Imagine that, at some initial point in the pipe, the fluid attributes are denoted with a subscript 1. And at some later point in the flow the fluid attributes are denoted with a subscript 2.

- (a) The work done by pressure force

$$dW = P dV$$

at points 1 and 2 is

$$\Delta W_1 = P_1 A_1 \Delta \ell_1 = P_1 \Delta V$$

and

$$\Delta W_2 = P_2 A_2 \Delta \ell_2 = P_2 \Delta V, .$$

- (b) The difference of the equations in part (a) is

$$\Delta W \equiv \Delta W_1 - \Delta W_2 = P_1 \Delta V - P_2 \Delta V .$$

- (c) Equating the last quantities with the change in total energy (written in the form kinetic energy plus potential energy) yields

$$\begin{aligned} \Delta W &= \Delta K + \Delta U \\ &= \frac{1}{2} \Delta m v_2^2 - \frac{1}{2} \Delta m v_1^2 + \Delta m g z_2 - \Delta m g z_1 . \end{aligned}$$

- (d) Identifying the last two equations gives

$$\frac{1}{2} \Delta m v_2^2 - \frac{1}{2} \Delta m v_1^2 + \Delta m g z_2 - \Delta m g z_1 = P_1 \Delta V - P_2 \Delta V .$$

- (d) Rearranging this last identity yields

$$\frac{\Delta m v_1^2}{2 \Delta V} + \frac{\Delta m g z_1}{\Delta V} + P_1 = \frac{\Delta m v_2^2}{2 \Delta V} + \frac{\Delta m g z_2}{\Delta V} + P_2 .$$

- (e) Now writing the density as
- $\rho = m/V$
- gives

$$\frac{1}{2} \rho v^2 + \rho g z + P = C ,$$

where C is a constant. This is Bernoulli's law.

Chapter 9

Harmonic Functions

9.1 Basic Properties of Harmonic Functions

9.1.1 The Laplace Equation

Let F be a holomorphic function on an open set $U \subseteq \mathbb{C}$. Write $F = u + iv$, where u and v are real-valued. The real part u satisfies a certain partial differential equation known as *Laplace's equation*:

$$\left(\frac{\partial^2}{\partial x^2} + \frac{\partial^2}{\partial y^2} \right) u = 0. \quad (9.1)$$

(Of course the imaginary part v satisfies the same equation.) The verification is immediate: We know that

$$\frac{\partial}{\partial \bar{z}} F = 0$$

hence

$$\frac{\partial}{\partial z} \frac{\partial}{\partial \bar{z}} F = 0.$$

Writing out this last equation and multiplying through by 4 gives

$$\left(\frac{\partial^2}{\partial x^2} + \frac{\partial^2}{\partial y^2} \right) F = 0.$$

Finally, breaking up this last identity into real and imaginary parts, we see that

$$\left(\frac{\partial^2}{\partial x^2} + \frac{\partial^2}{\partial y^2} \right) u + i \left(\frac{\partial^2}{\partial x^2} + \frac{\partial^2}{\partial y^2} \right) v = 0.$$

The only possible conclusion is that

$$\left(\frac{\partial^2}{\partial x^2} + \frac{\partial^2}{\partial y^2}\right)u \equiv 0 \quad \text{and} \quad \left(\frac{\partial^2}{\partial x^2} + \frac{\partial^2}{\partial y^2}\right)v \equiv 0.$$

In this chapter we shall study systematically those C^2 functions that satisfy this equation. They are called *harmonic* functions. (Note that we encountered some of these ideas already in Section 2.2.1)

9.1.2 Definition of Harmonic Function

Recall the precise definition of harmonic function:

A real-valued function $u : U \rightarrow \mathbb{R}$ on an open set $U \subseteq \mathbb{C}$ is *harmonic* if it is C^2 on U and

$$\Delta u \equiv 0, \tag{9.2}$$

where the Laplacian Δu is defined by

$$\Delta u = \left(\frac{\partial^2}{\partial x^2} + \frac{\partial^2}{\partial y^2}\right)u. \tag{9.3}$$

9.1.3 Real- and Complex-Valued Harmonic Functions

The definition of harmonic function just given applies as well to complex-valued functions. A complex-valued function is harmonic if and only if its real and imaginary parts are each harmonic.

The first thing that we need to check is that real-valued harmonic functions are just those functions that arise as the real parts of holomorphic functions—at least locally.

9.1.4 Harmonic Functions as the Real Parts of Holomorphic Functions

If $u : D(P, r) \rightarrow \mathbb{R}$ is a harmonic function on a disc $D(P, r)$, then there is a holomorphic function $F : D(P, r) \rightarrow \mathbb{C}$ such that $\operatorname{Re} F \equiv u$ on $D(P, r)$. Let us write $F = u + iv$. We treated this matter in some detail in Section 2.2.2, and shall not repeat the details here. We summarize the key idea with a theorem:

THEOREM 8 *If U is a simply connected open set (see Section 3.1.2) and if $u : U \rightarrow \mathbb{R}$ is a real-valued, harmonic function, then there is a C^2 (indeed a C^∞) real-valued, harmonic function v such that $u + iv : U \rightarrow \mathbb{C}$ is holomorphic.*

Another important relationship between harmonic and holomorphic functions is this:

If $u : U \rightarrow \mathbb{R}$ is harmonic on U and if $H : V \rightarrow U$ is holomorphic, then $u \circ H$ is harmonic on V .

This statement is of course proved by direct differentiation. We supply the details in a moment.

One verifies this last assertion by simply differentiating $u \circ H$ —using the chain rule. In detail:

$$\frac{\partial^2}{\partial z \partial \bar{z}}[u \circ H] = \frac{\partial}{\partial z} \left[\frac{\partial u}{\partial z} \cdot \frac{\partial H}{\partial \bar{z}} + \frac{\partial u}{\partial \bar{z}} \cdot \frac{\partial \bar{H}}{\partial \bar{z}} \right] = \frac{\partial}{\partial z} \left[\frac{\partial u}{\partial \bar{z}} \cdot \frac{\partial \bar{H}}{\partial \bar{z}} \right].$$

Now we apply the second derivative to obtain (after a little calculation)

$$\frac{\partial^2 u}{\partial z \partial \bar{z}} \cdot \frac{\partial H}{\partial z} \cdot \frac{\partial \bar{H}}{\partial \bar{z}} = 0$$

because u is harmonic.

9.1.5 Smoothness of Harmonic Functions

If $u : U \rightarrow \mathbb{R}$ is a harmonic function on an open set $U \subseteq \mathbb{C}$, then $u \in C^\infty$. In fact a harmonic function is always real analytic (has a local power series expansion in powers of x and y). This follows, for instance, because a harmonic function is locally the real part of a holomorphic function (see Sections 2.2.2 and 9.1.4). And of course a holomorphic function has a local power series expansion about each point. So, in particular, it is infinitely differentiable.

Exercises

1. Suppose that u_1 and u_2 have the same harmonic conjugate. Prove that u_1 and u_2 differ by a constant.

2. Suppose that h is a holomorphic function on a domain U and that the real part of h is constant. What does that tell you about h ?
3. Let u be a harmonic function on a domain U and $u \equiv 0$ on a nonempty open subset $V \subseteq U$. What does that tell you about u ?
4. Let $u(x, y) = x^2 - y^2$. Verify that u is harmonic. Now find a harmonic function v on the unit disc so that $u + iv$ is holomorphic.
5. Let $u(x, y) = e^x \cos y$. Verify that u is harmonic. Now find a harmonic function v on the unit disc so that $u + iv$ is holomorphic.
6. Let U be a domain in \mathbb{C} and let $E \subseteq U$ be a nontrivial line segment. If h is a holomorphic function on U and $h \Big|_E = 0$ then it follows that $h \equiv 0$. Why? But the same assertion is not true for a harmonic function. Give an example to explain why not.
7. If u is harmonic and real-valued on a domain U and u^2 is harmonic on U then prove that u is constant.
8. Let u be harmonic on a domain U and suppose that $u \cdot v$ is harmonic for every harmonic function v on U . Then prove that u is constant.
9. Let u be harmonic and real-valued and nonvanishing on a domain U . Let $p \geq 1$. Show that $\Delta |u|^p = p(p-1)|u|^{p-2}|\nabla u|^2$.
10. Prove that if u is real-valued and harmonic on a domain $U \subseteq \mathbb{C}$ then, about each point $P \in U$, u has a power series expansion. This will not be simply a power series expansion in z alone, but rather in z and \bar{z} or, equivalently, in x and y .
11. If f is a nonvanishing holomorphic function on a domain U then prove that $\log |u|$ is harmonic on U .
12. Prove that if u is a real-valued, harmonic polynomial then its harmonic conjugate is also a polynomial.
13. Refer to the last exercise. Write a `MatLab` routine to find the harmonic conjugate polynomial of a given real-valued harmonic polynomial.

14. We think of a holomorphic function as representing an incompressible fluid flow by identifying the holomorphic function $h(z) = h(x + iy) = u(x + iy) + iv(x + iy)$ with $(u(x, y), v(x, y))$. Passing to the real part u of course yields a harmonic function. What does passing to u mean in terms of the fluid flow? What does its harmonicity mean in physical terms?

9.2 The Mean Value Property and the Maximum Principle

9.2.1 The Mean Value Property

Suppose that $u : U \rightarrow \mathbb{R}$ is a harmonic function on an open set $U \subseteq \mathbb{C}$ and that $\overline{D}(P, r) \subseteq U$ for some $r > 0$. Then

$$u(P) = \frac{1}{2\pi} \int_0^{2\pi} u(P + re^{i\theta}) d\theta. \quad (9.4)$$

To understand why this result is true, let us simplify matters by assuming (with a simple translation of coordinates) that $P = 0$. Notice that if $k > 0$ and $u(z) = z^k$ then

$$\frac{1}{2\pi} \int_0^{2\pi} u(P + re^{i\theta}) d\theta = \frac{1}{2\pi} \int_0^{2\pi} (re^{i\theta})^k d\theta = r^k \frac{1}{2\pi} \int_0^{2\pi} e^{ik\theta} d\theta = 0 = u(0).$$

The same holds when $k = 0$ by a similar calculation. So that is the mean value property for powers of z . But any holomorphic function is a sum of powers of z , so it follows that the mean value property will hold for any holomorphic function.

Finally, any harmonic function is the real part of a holomorphic function (at least locally on a disc) so that the result for harmonic functions follows by taking real parts.

We conclude this section with two alternative formulations of the mean value property (MVP). In both, u, U, P, r are as above.

First Alternative Formulation of MVP

$$u(P) = \frac{1}{\pi r^2} \iint_{D(P,r)} u(x, y) dx dy. \quad (9.5)$$

Second Alternative Formulation of MVP

$$u(P) = \frac{1}{2\pi r} \int_{\partial D(P,r)} u(\zeta) d\sigma(\zeta), \quad (9.6)$$

where $d\sigma$ is arc-length measure on $\partial D(P, r)$.

The proof of either of these results is a simple exercise with calculus.

9.2.2 The Maximum Principle for Harmonic Functions

If $u : U \rightarrow \mathbb{R}$ is a real-valued, harmonic function on a connected open set U and if there is a point $P_0 \in U$ with the property that $u(P_0) = \max_{z \in U} u(z)$, then u is constant on U .

Compare the maximum modulus principle for holomorphic functions in Section 6.4.1. We also considered this phenomenon in Exercise 8 of Section 6.4. We shall learn another way to understand this maximum principle when we study its relation to the mean value property below.

9.2.3 The Minimum Principle for Harmonic Functions

If $u : U \rightarrow \mathbb{R}$ is a real-valued, harmonic function on a connected open set $U \subseteq \mathbb{C}$ and if there is a point $P_0 \in U$ such that $u(P_0) = \min_{Q \in U} u(Q)$, then u is constant on U .

Compare the minimum principle for holomorphic functions in Section 6.4.3. The reader may note that the minimum principle for holomorphic functions requires an extra hypothesis (that is, nonvanishing of the function) while that for harmonic functions does not. The difference may be explained by noting that with harmonic functions we are considering the real-valued function u , while with holomorphic functions we must restrict attention to the modulus function $|f|$ (since the complex numbers do not form an ordered field).

9.2.4 Why the Mean Value Property Implies the Maximum Principle

Let u be a real-valued harmonic function on a domain U and suppose that $u(P) \geq u(z)$ for some fixed $P \in U$ and every $z \in U$. We will use the mean value property to show that u must be constant.

Let

$$S = \{z \in U : u(z) = u(P)\}.$$

Of course S is nonempty since $P \in S$. Also S is closed because u is a continuous function. To see that S is open let $r > 0$ be small. Let $z \in S$. Set $\lambda = u(P)$. Then, by the mean value property,

$$\lambda = u(z) = \frac{1}{2\pi} \int_0^{2\pi} u(z + re^{i\theta}) d\theta \leq \frac{1}{2\pi} \int_0^{2\pi} \lambda d\theta = \lambda.$$

Since the integral is trapped between λ and λ , we can only conclude that it equals λ . Since $u \leq \lambda$ at all points, we can only conclude that $u(z + re^{i\theta}) = \lambda$ for all θ . This equality also holds for all small r . We conclude that there is an entire disc about z that lies in S . So S is open.

We have proved that S is open, closed, and nonempty. It follows that cS is also open. So S and cS are two disjoint open sets that disconnect U , and that is impossible. The only conclusion is that $S = U$, so that u is constant, indeed is constantly equal to λ .

9.2.5 The Boundary Maximum and Minimum Principles

An important and intuitively appealing consequence of the maximum principle is the following result (which is sometimes called the “boundary maximum principle”). Recall that a continuous function on a compact set assumes a maximum value (and also a minimum value)—see [KRA2], [RUD1]. When the function is harmonic, the maximum occurs at the boundary in the following precise sense:

Let $U \subseteq \mathbb{C}$ be a bounded domain. Let u be a continuous, real-valued function on the closure \bar{U} of U that is harmonic on U . Then

$$\max_{\bar{U}} u = \max_{\partial U} u. \quad (9.7)$$

The analogous result for the minimum is:

Let $U \subseteq \mathbb{C}$ be a bounded domain. Let u be a continuous, real-valued function on the closure \bar{U} of U that is harmonic on U . Then

$$\min_{\bar{U}} u = \min_{\partial U} u. \quad (9.8)$$

Compare the analogous results for holomorphic functions in Sections 6.4.1 and 6.4.3.

9.2.6 Boundary Uniqueness for Harmonic Functions

If $u_1 : \overline{D}(0, 1) \rightarrow \mathbb{R}$ and $u_2 : \overline{D}(0, 1) \rightarrow \mathbb{R}$ are two continuous functions, each of which is harmonic on $D(0, 1)$ and if $u_1 = u_2$ on $\partial D(0, 1) = \{z : |z| = 1\}$, then $u_1 \equiv u_2$. This assertion follows from the boundary maximum principle (9.7) applied to $u_1 - u_2$. Thus, in effect, a harmonic function u on $D(0, 1)$ that extends continuously to $\overline{D}(0, 1)$ is completely determined by its values on $\overline{D}(0, 1) \setminus D(0, 1) = \partial D(0, 1)$.

Exercises

1. Let u be any harmonic function on a domain $U \subseteq \mathbb{C}$. In general it will *not* be the case that $|u|$ is harmonic (give an example). But it will be true that, for any $\overline{D}(P, r) \subseteq U$, we have the *submean value property*

$$|u(P)| \leq \frac{1}{2\pi} \int_0^{2\pi} |u(P + re^{it})| dt.$$

Prove this last inequality.

2. Verify directly, with a calculation, that the mean value property holds for the harmonic function $u(x, y) = x^2 - y^2$.
3. Verify directly, with a calculation, that the mean value property holds for the harmonic function $u(x, y) = e^y \sin x$.
4. Do you find it curious that the mean value property is formulated in terms of the average over circles? Could there be a mean value property over squares? The answer is *no*. Provide an example to show that the mean value property does *not* hold over the unit square.
5. Refer to Exercise 1. If u is harmonic and real-valued then it will satisfy the mean value property. In general we cannot expect that u^2 will satisfy the mean value property—after all, in general, u^2 will not be harmonic. But u^2 *will* satisfy a submean value property. Verify this claim.

6. Use calculus to give a proof of the First Alternative Formulation of the MVP.
7. Use calculus to give a proof of the Second Alternative Formulation of the MVP.
8. Show directly that if h is holomorphic and nonvanishing then $\log |h|$ satisfies the mean value property.
9. Write a `MatLab` routine that will calculate the Laplacian of any given function.
10. What does the boundary maximum principle tell us about fluid flows? What does it say about electrostatics?
11. Refer to the last exercise. Write a `MatLab` routine that will calculate the Laplacian of a given function and then test whether that Laplacian is nonnegative at every point.

9.3 The Poisson Integral Formula

9.3.1 The Poisson Integral

The next result shows how to calculate a harmonic function on the disc from its “boundary values,” that is, its values on the circle that bounds the disc.

Let $u : U \rightarrow \mathbb{R}$ be a harmonic function on a neighborhood of $\overline{D}(0, 1)$. Then, for any point $a \in D(0, 1)$,

$$u(a) = \frac{1}{2\pi} \int_0^{2\pi} u(e^{i\psi}) \cdot \frac{1 - |a|^2}{|a - e^{i\psi}|^2} d\psi. \quad (9.9)$$

9.3.2 The Poisson Kernel

The expression

$$\frac{1}{2\pi} \frac{1 - |a|^2}{|a - e^{i\psi}|^2} \quad (9.10)$$

is called the *Poisson kernel* for the unit disc. It is often convenient to rewrite the formula we have just enunciated by setting $a = |a|e^{i\theta} = re^{i\theta}$. Then the

result says that

$$u(re^{i\theta}) = \frac{1}{2\pi} \int_0^{2\pi} u(e^{i\psi}) \frac{1-r^2}{1-2r\cos(\theta-\psi)+r^2} d\psi. \quad (9.11)$$

In other words

$$u(re^{i\theta}) = \int_0^{2\pi} u(e^{i\psi}) P_r(\theta-\psi) d\psi, \quad (9.12)$$

where

$$P_r(\theta-\psi) = \frac{1}{2\pi} \frac{1-r^2}{1-2r\cos(\theta-\psi)+r^2}. \quad (9.13)$$

In fact this new integral formula follows rather naturally from results that we already know—if we simply remember to think of a harmonic function as the real part of a holomorphic function. Details of these assertions are provided below.

We begin our discussion by noting that if we let $z = re^{i\theta}$ and $\zeta = e^{i\psi}$ then we may rewrite

$$P_r(\theta-\psi) = \frac{1}{2\pi} \frac{1-r^2}{1-2r\cos(\theta-\psi)+r^2} = \frac{1}{2\pi} \frac{1-r^2}{|re^{i\theta} - e^{i\psi}|^2} = \frac{1}{2\pi} \frac{1-|z|^2}{|z-\zeta|^2}.$$

This shows explicitly how the two expressions for the Poisson kernel are related.

9.3.3 The Dirichlet Problem

The Poisson integral formula both reproduces and creates harmonic functions. In contrast to the holomorphic case, there is a simple connection between a continuous function f on $\partial D(0, 1)$ and the created harmonic function u on D . The following theorem states this connection precisely. The theorem is usually called “the solution of the Dirichlet problem on the disc”:

9.3.4 The Solution of the Dirichlet Problem on the Disc

Let f be a continuous function on $\partial D(0, 1)$. Define

$$u(z) = \begin{cases} \frac{1}{2\pi} \int_0^{2\pi} f(e^{i\psi}) \cdot \frac{1-|z|^2}{|z-e^{i\psi}|^2} d\psi & \text{if } z \in D(0, 1) \\ f(z) & \text{if } z \in \partial D(0, 1). \end{cases} \quad (9.14)$$

Then u is continuous on $\overline{D}(0, 1)$ and harmonic on $D(0, 1)$.

Closely related to this result is the *reproducing property* of the Poisson kernel:

Let u be continuous on $\overline{D}(0, 1)$ and harmonic on $D(0, 1)$. Then, for $z \in D(0, 1)$,

$$u(z) = \frac{1}{2\pi} \int_0^{2\pi} u(e^{i\psi}) \cdot \frac{1 - |z|^2}{|z - e^{i\psi}|^2} d\psi. \quad (9.15)$$

See (9.9).

Let us begin by verifying formula (9.15). We assume for simplicity that the function u is harmonic on a neighborhood of $\overline{D}(0, 1)$. Let $z \in D(0, 1)$ be a fixed point. Consider the function $u \circ \varphi_{-z}$, where

$$\phi_a(\zeta) = \frac{\zeta - a}{1 - \bar{a}\zeta}$$

for any complex number a with $|a| < 1$. It is still harmonic, so it satisfies the mean value property. We calculate

$$\begin{aligned} u \circ \varphi_{-z}(0) &= \frac{1}{2\pi} \int_0^{2\pi} u \circ \varphi_{-z}(e^{it}) dt \\ &= \frac{1}{2\pi i} \oint_{\partial D(0,1)} \frac{u \circ \varphi_{-z}(\zeta)}{\zeta} d\zeta \end{aligned}$$

Notice that we have transformed the real integral, which is what is usually used to express the mean value property, to a complex line integral. In doing so, we have kept in mind that $\zeta = e^{it}$ and $d\zeta = ie^{it} dt$. This will facilitate

the change of variable that we must perform. Now we have that this last

$$\begin{aligned}
&= \frac{1}{2\pi i} \oint_{\partial D(0,1)} \frac{u(\xi)}{\varphi_z(\xi)} \varphi'_z(\xi) d\xi \\
&= \frac{1}{2\pi i} \oint_{\partial D(0,1)} \frac{u(\xi)}{\frac{\xi-z}{1-\bar{z}\xi}} \cdot \frac{1-|z|^2}{(1-\bar{z}\xi)^2} d\xi \\
&= \frac{1}{2\pi i} \oint_{\partial D(0,1)} u(\xi) \cdot \frac{1-|z|^2}{(\xi-z)(1-\bar{z}\xi)} d\xi \\
&= \frac{1}{2\pi i} \oint_{\partial D(0,1)} u(\xi) \cdot \frac{1-|z|^2}{(\xi-z)(\bar{\xi}-\bar{z})} \cdot \bar{\xi} d\xi \\
&= \frac{1}{2\pi i} \oint_{\partial D(0,1)} u(\xi) \cdot \frac{1-|z|^2}{|\xi-z|^2} \cdot \bar{\xi} d\xi \\
&= \frac{1}{2\pi} \int_0^{2\pi} u(e^{it}) \cdot \frac{1-|z|^2}{|z-e^{it}|^2} d\psi.
\end{aligned}$$

Here again we have interpreted the complex line integral as a real integral, using $\xi = e^{it}$, $d\xi = ie^{it}$. This is formula (9.15).

9.3.5 The Dirichlet Problem on a General Disc

A change of variables shows that the results of Section 9.3.4 remain true on a general disc. To wit, let f be a continuous function on $\partial D(P, r)$. Define

$$u(z) = \begin{cases} \frac{1}{2\pi} \int_0^{2\pi} f(P + re^{i\psi}) \cdot \frac{r^2 - |z - P|^2}{|(z - P) - re^{i\psi}|^2} d\psi & \text{if } z \in D(P, r) \\ f(z) & \text{if } z \in \partial D(P, r). \end{cases} \quad (9.16)$$

Then u is continuous on $\bar{D}(P, r)$ and harmonic on $D(P, r)$.

If instead u is continuous on $\bar{D}(P, r)$ and harmonic on $D(P, r)$, then, for $z \in D(P, r)$,

$$u(z) = \frac{1}{2\pi} \int_0^{2\pi} u(P + re^{i\psi}) \cdot \frac{r^2 - |z - P|^2}{|(z - P) - re^{i\psi}|^2} d\psi. \quad (9.17)$$

Exercises

1. Explicitly calculate the Poisson integral on the unit disc of the function

$$f(e^{it}) = \begin{cases} 1 & \text{if } 0 \leq t \leq \pi \\ -1 & \text{if } \pi < t \leq 2\pi. \end{cases}$$

2. Verify by direct calculation that the Poisson kernel

$$\frac{1 - |z|^2}{|z - e^{it}|^2}$$

is harmonic as a function of z .

3. Refer to Exercise 2. The Cauchy integral formula on the unit disc says that, for a holomorphic function f ,

$$f(z) = \frac{1}{2\pi i} \oint_{\partial D(0,1)} \frac{f(\zeta)}{\zeta - z} d\zeta.$$

Of course, for $\zeta \in \partial D(0, 1)$ fixed, the Cauchy kernel

$$C(z, \zeta) = \frac{1}{\zeta - z}$$

is holomorphic as a function of z . It turns out that the real part of

$$\frac{1}{2\pi i} \cdot \frac{1}{\zeta - z} d\zeta - \frac{1}{4\pi}$$

equals half of the Poisson kernel. Prove this last statement. This gives another way to see that the Poisson kernel is harmonic as a function of z .

4. Derive formula (9.17) from formula (9.15).
5. It can be proved from the second law of thermodynamics (see [KRA1]) that if f is an initial distribution of heat on the boundary of a unit aluminum disc, then the solution of the Dirichlet problem on that disc (given by the Poisson integral) is the steady state heat distribution on the disc induced by f . Use physical reasoning to draw some conclusions about the steady state heat distribution for the f given in Exercise 1.

What will be the value of the heat distribution at the origin? What will be the nature of the heat distribution in the *upper half* of the disc? What will be the nature of the heat distribution in the lower half of the disc?

6. If $f_k(e^{it}) = e^{ikt}$ for k a nonnegative integer then the solution of the Dirichlet problem on the unit disc with boundary data f_k is z^k . Prove this result. If instead $f_k(e^{it}) = e^{ikt}$ for k a negative integer then the solution of the Dirichlet problem on the unit disc with boundary data f_k is \bar{z}^{-k} . Prove this result.
7. Refer to Exercise 6. If we use the theory of Fourier series (Section 11.1) then we can express an arbitrary $f(e^{it})$ as

$$f(e^{it}) = \sum_{n=-\infty}^{\infty} a_n e^{int}.$$

This suggests that the corresponding solution of the Dirichlet problem will be

$$u(z) = \sum_{n=0}^{\infty} a_n z^n + \sum_{n=-\infty}^{-1} a_n \bar{z}^{-n},$$

where $z = re^{i\theta}$. Apply this philosophy to the boundary function $f(e^{it}) = \sin 2t$. Apply this philosophy to the boundary function $f(e^{it}) = \cos^2 t$.

8. Write a `MatLab` routine that will calculate the Poisson integral on the disc of any given function (on the boundary of the disc).

Chapter 10

Transform Theory

10.0 Introductory Remarks

This chapter will sketch some connections of Fourier series, the Fourier transform, and the Laplace transform with the theory of complex variables. This will not be a tutorial in any of these three techniques. The reader who desires background should consult the delightful texts [DYM] or [KAT].

The idea of Fourier series or Fourier transforms is to take a function f that one wishes to analyze and to assign to f a new function \widehat{f} that contains information about the frequencies that are built into the function f . As such, the Fourier theory is a real variable theory. But complex variables can come to our aid in the calculation of, and also in the analysis of, \widehat{f} . It is that circle of ideas that will be explained in the present chapter.

10.1 Fourier Series

10.1.1 Basic Definitions

Fourier series takes place on the interval $[0, 2\pi)$. We think of the endpoints of this interval as being identified with each other, so that geometrically our analysis is taking place on a circle (Figure 10.1). It may be noted that the function $\phi(\theta) = e^{i\theta}$ takes the interval $[0, 2\pi)$ in a one-to-one, onto fashion to the circle (or the boundary of the unit disc). If f is an integrable function

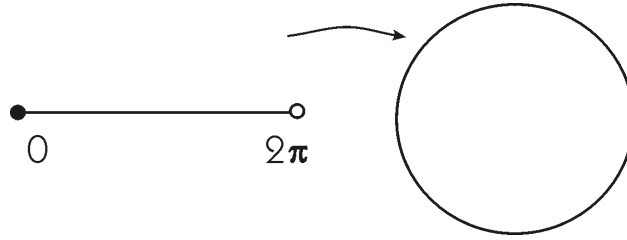


Figure 10.1: Identification of the interval with the circle.

on $[0, 2\pi)$, then we *define*¹

$$\widehat{f}(n) = \frac{1}{2\pi} \int_0^{2\pi} f(t)e^{-int} dt \quad \text{for } n \in \mathbb{Z}. \quad (10.1)$$

The *Fourier series* of f is the formal expression

$$Sf(t) \sim \sum_{n=-\infty}^{\infty} \widehat{f}(n)e^{int}. \quad (10.2)$$

We call this a “formal expression” because we do not know a priori whether this series converges in any sense, and if it does converge, whether its limit is the original function f .

There is a highly developed theory of the convergence of Fourier series, but this is not the proper context in which to describe those results. Let us simply formulate one of the most transparent and useful theorems.

The partial sums of the Fourier series Sf are defined to be

$$S_N f(t) \equiv \sum_{n=-N}^N \widehat{f}(n)e^{int}. \quad (10.3)$$

We say that the Fourier series *converges* to the function f at the point t if

$$\lim_{N \rightarrow \infty} S_N f(t) = f(t). \quad (10.4)$$

¹Already, in this particular version of the definition of the Fourier coefficients, we see complex variables coming into play. We should note that many treatments (see, for example, [SIK]) define coefficients $a_0 = [1/(2\pi)] \int_{-\pi}^{\pi} f(t) dt$, $a_n = [1/\pi] \int_{-\pi}^{\pi} f(t) \cos nt dt$, $b_n = [1/\pi] \int_{-\pi}^{\pi} f(t) \sin nt dt$ for $n \geq 1$. This is an equivalent formulation, but avoids the use of complex variables.

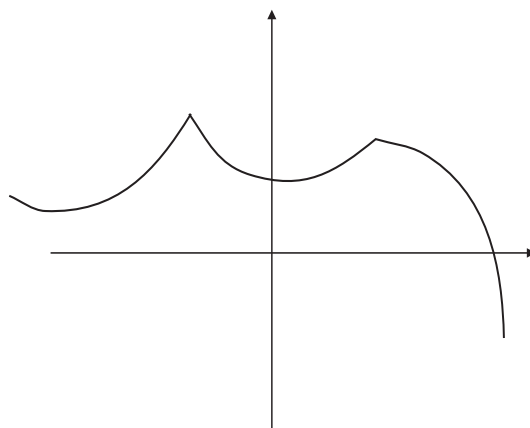


Figure 10.2: A piecewise differentiable function.

Theorem: Let f be an integrable function on $[0, 2\pi)$. If t_0 is a point of differentiability of f , then the Fourier series Sf converges to f at t_0 .

Many functions that we encounter in practice are piecewise differentiable (see Figure 10.2), so this is a theorem that is straightforward to apply. In fact, if f is continuously differentiable on a compact interval I , then the Fourier series converges absolutely and uniformly to the original function f . In this respect Fourier series are much more attractive than Taylor series; for the Taylor series of even a C^∞ function f typically does not converge, and even when it does converge, it typically does not converge² to f .

10.1.2 A Remark on Intervals of Arbitrary Length

It is frequently convenient to let the interval $[-\pi, \pi)$ be the setting for our study of Fourier series. Since we think of the function f as being 2π -periodic, this results in no change in the notation or in the theory.

In applications, one often wants to do Fourier series analysis on an interval $[-L/2, L/2)$. In this setting the notation is adjusted as follows: For a function

²This is really a very subtle point, and we cannot dwell on it here. The book [KRP] discusses the matter in considerable detail. See also [KRA2].

f that is integrable on $[-L/2, L/2]$, we define

$$\widehat{f}(n) = \frac{1}{L} \int_{-L/2}^{L/2} f(t) e^{-in2\pi/L} dt \quad (10.5)$$

and set the Fourier series of f equal to

$$Sf(t) \sim \sum_{n=-\infty}^{\infty} \widehat{f}(n) e^{in2\pi t/L}. \quad (10.6)$$

We shall say no more about Fourier analysis on $[-L/2, L/2)$ at this time.

10.1.3 Calculating Fourier Coefficients

The key to using complex analysis for the purpose of computing Fourier series is to note that, when $n \geq 0$, the function $\varphi_n(t) = e^{int}$ is the “boundary function” of the holomorphic function z^n . What does this mean?

We identify the interval $[0, 2\pi)$ with the unit circle S in the complex plane by way of the map

$$\begin{aligned} M : [0, 2\pi) &\longrightarrow S \\ t &\longmapsto e^{it}. \end{aligned} \quad (10.7)$$

Of course the circle S is the boundary of the unit disc D . If we let z be a complex variable, then, when $|z| = 1$, we know that z has the form $z = e^{it}$ for some real number t between 0 and 2π . Thus the holomorphic (analytic) function z^n , $n \geq 0$, takes the value $(e^{it})^n = e^{int}$ on the circle. By the same token, when $n < 0$, then the meromorphic function z^n takes the value $(e^{it})^n = e^{int}$ on the circle. In this way we associate, in a formal fashion, the meromorphic function

$$F(z) = \sum_{n=-\infty}^{\infty} \widehat{f}(n) z^n \quad (10.8)$$

with the Fourier series

$$Sf(t) \sim \sum_{n=-\infty}^{\infty} \widehat{f}(n) e^{int}. \quad (10.9)$$

This association is computationally useful, as the next example shows.

10.1.4 Calculating Fourier Coefficients Using Complex Analysis

Let us calculate the Fourier coefficients of the function $f(t) = e^{2i \sin t}$ using complex variable theory. We first recall that

$$\sin t = \frac{1}{2i} [e^{it} - e^{-it}] \quad (10.10)$$

so that

$$2i \sin t = e^{it} - \frac{1}{e^{it}}.$$

Thus, using the ideas from Section 10.1.3, we associate to $2i \sin t$ the analytic function

$$z - \frac{1}{z}. \quad (10.11)$$

As a result, we associate to f the analytic function

$$F(z) = e^{z-1/z} = e^z \cdot e^{-z^{-1}}. \quad (10.12)$$

But the function on the right is easy to expand in a series:

$$\begin{aligned} F(z) &= e^z \cdot e^{-z^{-1}} \\ &= \left[\sum_{k=0}^{\infty} \frac{z^k}{k!} \right] \cdot \left[\sum_{\ell=0}^{\infty} \frac{(-1)^\ell z^{-\ell}}{\ell!} \right]. \end{aligned} \quad (10.13)$$

By the theory of the Cauchy product of series (see [KRA2]), two convergent power series may be multiplied together in just the same way as two polynomials: we multiply term by term and then gather together the resulting terms with the same power of z . We therefore find that

$$F(z) = \sum_{n=-\infty}^{\infty} z^n \left[\sum_{m=n}^{\infty} \frac{1}{m!} \frac{(-1)^{m-n}}{(m-n)!} \right]. \quad (10.14)$$

In conclusion, we see that the Fourier series of our original function f is

$$Sf(x) \sim \sum_{-\infty}^{\infty} \widehat{f}(n) e^{inx} \quad (10.15)$$

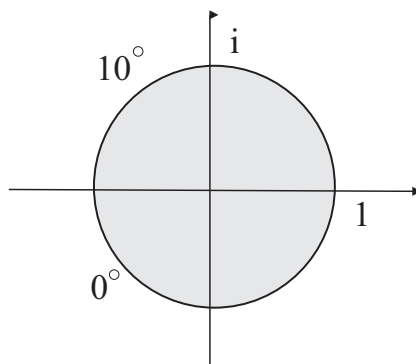


Figure 10.3: Mathematical model of the disc.

with

$$\hat{f}(n) = \sum_{m=n}^{\infty} \frac{1}{m!} \frac{(-1)^n}{(m-n)!}. \quad (10.16)$$

□

10.1.5 Steady State Heat Distribution

The next example will harken back to our discussion of heat diffusion in Section 8.2.2. But we will now use some ideas from Fourier series and from Laurent series.

EXAMPLE 55 Suppose that a thin metal heat-conducting plate is in the shape of a round disc and has radius 1. Imagine that the upper half of the circular boundary of the plate is held at constant temperature 10° and the lower half of the circular boundary is held at constant temperature 0° . Describe the steady state heat distribution on the entire plate.

□

Solution: Model the disc with the interior of the unit circle in the complex plane (Figure 10.3). Identifying $[0, 2\pi)$ with the unit circle as in Section 10.1.3, we are led to consider the function

$$f(t) = \begin{cases} 10 & \text{if } 0 \leq t \leq \pi \\ 0 & \text{if } \pi \leq t < 2\pi. \end{cases} \quad (10.17)$$

Then

$$\widehat{f}(0) = \frac{1}{2\pi} \int_0^\pi 10 \, dt + \frac{1}{2\pi} \int_\pi^{2\pi} 0 \, dt = 5 \quad (10.18)$$

and, for $n \neq 0$,

$$\widehat{f}(n) = \frac{1}{2\pi} \int_0^\pi 10 \cdot e^{-int} \, dt + \frac{1}{2\pi} \int_\pi^{2\pi} 0 \cdot e^{-int} \, dt = \frac{1}{2\pi} \frac{10}{in} [1 - e^{-in\pi}]. \quad (10.19)$$

As a result,

$$\begin{aligned} Sf &\sim 5 + \sum_{-\infty}^{-1} \frac{1}{2\pi} \cdot \frac{10}{in} [1 - e^{-in\pi}] e^{int} + \sum_{n=1}^{\infty} \frac{1}{2\pi} \cdot \frac{10}{in} [1 - e^{-in\pi}] e^{int} \\ &= 5 + \sum_{n=1}^{\infty} \frac{1}{2\pi} \cdot \frac{10}{-in} [1 - e^{in\pi}] e^{-int} + \sum_{n=1}^{\infty} \frac{1}{2\pi} \cdot \frac{10}{in} [1 - e^{-in\pi}] e^{int} \\ &= 5 + 2\operatorname{Re} \left(\sum_{n=1}^{\infty} \frac{1}{2\pi} \cdot \frac{10}{in} [1 - e^{-in\pi}] e^{int} \right) \end{aligned} \quad (10.20)$$

Of course the expression in brackets is 0 when n is even. So we can rewrite our formula for the Fourier series as

$$Sf \sim 5 + \frac{20}{\pi} \operatorname{Re} \left(\frac{1}{i} \sum_{k=0}^{\infty} \frac{1}{2k+1} e^{i(2k+1)t} \right). \quad (10.21)$$

This series is associated, just as we discussed in Section 10.1.3, with the analytic function

$$F(z) = 5 + \frac{20}{\pi} \operatorname{Re} \left(\frac{1}{i} \sum_{k=0}^{\infty} \frac{1}{2k+1} z^{(2k+1)} \right). \quad (10.22)$$

To sum the series

$$\sum_{k=0}^{\infty} \frac{1}{2k+1} z^{2k+1}, \quad (10.23)$$

we write it as

$$\sum_{k=0}^{\infty} \int_0^z \zeta^{2k} d\zeta = \int_0^z \left[\sum_{k=0}^{\infty} \zeta^{2k} \right] d\zeta, \quad (10.24)$$

where we have used the fact that integrals and convergent power series commute. But

$$\frac{1}{1-\alpha} = 1 + \alpha + \alpha^2 + \dots \quad (10.25)$$

is a familiar power series expansion. Using this series with $\alpha = z^2$ we find that

$$\sum_{k=0}^{\infty} \frac{1}{2k+1} z^{2k+1} = \int_0^z \frac{1}{1-\zeta^2} d\zeta = \frac{1}{2} \log \left(\frac{1+z}{1-z} \right). \quad (10.26)$$

Putting this information into (10.22) yields

$$\begin{aligned} F(z) &= 5 + \frac{10}{\pi} \operatorname{Re} \left[\frac{1}{i} \log \left(\frac{1+z}{1-z} \right) \right] \\ &= 5 + \frac{10}{\pi} \arg \left(\frac{1+z}{1-z} \right). \end{aligned} \quad (10.27)$$

This function $F(z) = F(re^{i\theta})$ is the harmonic function on the disc with boundary function f . It is therefore the solution to our heat diffusion problem. \square

10.1.6 The Derivative and Fourier Series

Now we show how complex variables can be used to discover important formulas about Fourier coefficients. In this subsection we concentrate on the derivative.

Let f be a C^1 function on $[0, 2\pi)$. Assume that $f(0) = \lim_{t \rightarrow 2\pi^-} f(t)$ and that $f'(0) = \lim_{t \rightarrow 2\pi^-} f'(t)$, so that the values of f and its derivative match up at the endpoints. We want to consider how the Fourier series of f relates to the Fourier series of f' . We proceed formally.

We write

$$f(t) \sim \sum_{n=-\infty}^{\infty} \widehat{f}(n)e^{int} \quad (10.28)$$

and hence we have the associated analytic function (on the punctured disc)

$$F(z) = \sum_{n=-\infty}^{\infty} \widehat{f}(n)z^n. \quad (10.29)$$

A convergent power series may be differentiated term-wise, so we have

$$F'(z) = \frac{dF}{dz}(z) = \sum_{n=-\infty}^{\infty} n\widehat{f}(n)z^{n-1}. \quad (10.30)$$

But, with $z = e^{it}$, we have

$$\frac{dz}{dt} = \frac{d}{dt}e^{it} = ie^{it} = iz, \quad (10.31)$$

so the chain rule tells us that

$$\begin{aligned} \frac{dF}{dt} &= \frac{dF}{dz} \cdot \frac{dz}{dt} \\ &= \sum_{n=-\infty}^{\infty} n\widehat{f}(n)z^{n-1} \cdot (iz) \\ &= \sum_{n=-\infty}^{\infty} in\widehat{f}(n)z^n \\ &= \sum_{n=-\infty}^{\infty} in\widehat{f}(n)e^{int}. \end{aligned}$$

We conclude that the Fourier series for $f'(t)$ is

$$\sum_{n=-\infty}^{\infty} in\widehat{f}(n)e^{int}, \quad (10.32)$$

and that the Fourier coefficients for $f'(t)$ are

$$[f']^{\widehat{}} = in\widehat{f}(n). \quad (10.33)$$

□

EXAMPLE 56 Let us illustrate the utility of our formula for the Fourier coefficients of the derivative by solving a differential equation. Consider the equation

$$f' + f = \cos t. \quad (10.34)$$

Working formally, we set

$$f(t) \sim \sum_{n=-\infty}^{\infty} \widehat{f}(n)e^{int}.$$

Then, as we have just learned, we have

$$f'(t) \sim \sum_{n=-\infty}^{\infty} in\widehat{f}(n)e^{int}.$$

Putting this information into the differential equation (10.34) yields

$$\sum_{n=-\infty}^{\infty} in\widehat{f}(n)e^{int} + \sum_{n=-\infty}^{\infty} \widehat{f}(n)e^{int} = \cos t$$

or

$$\sum_{n=-\infty}^{\infty} (1 + in)\widehat{f}(n)e^{int} = \frac{1}{2}e^{-it} + \frac{1}{2}e^{it}.$$

An essential fact about Fourier series is that any given function has one and only one Fourier series expansion. In other words, if two Fourier series are equal then their Fourier coefficients must be equal. We conclude therefore that

- $\widehat{f}(n) = 0$ when $|n| \geq 2$,
- $(1 - i)\widehat{f}(-1) = \frac{1}{2}$,
- $(1 + i)\widehat{f}(1) = \frac{1}{2}$,
- $\widehat{f}(0) = 0$.

Thus the upshot of our calculation is that

$$\widehat{f}(-1) = \frac{1}{4} + i\frac{1}{4} \quad \text{and} \quad \widehat{f}(1) = \frac{1}{4} - i\frac{1}{4}.$$

So we see that a solution³ of the original differential equation (10.34) is

$$f(t) = \left(\frac{1}{4} + i\frac{1}{4}\right) e^{-it} + \left(\frac{1}{4} - i\frac{1}{4}\right) e^{it} = \frac{1}{2} \cos t + \frac{1}{2} \sin t.$$

We invite the reader to substitute this formula for f into (10.34) and verify that it is indeed a solution. \square

Exercises

- Calculate the Fourier coefficients $\widehat{f}(j)$ for each of the following functions on $[0, 2\pi)$.
 - $f(t) = t^2$
 - $f(t) = \cos 2t$
 - $f(t) = 3 \sin 4t$
 - $f(t) = e^t$
 - $f(t) = \sin t \cos t$
 - $f(t) = \cos^2 t$
 - $f(t) = \sin^3 t$
 - $f(t) = t \sin t$
- Use complex variable techniques to calculate the Fourier series of the function $f(t) = e^{i \cos t}$.
- Calculate the Fourier series of the function $f(t) = t^2$ on the interval $[-2, 2]$.
- Calculate the Fourier series of the function $f(t) = \cos t$ on the interval $[-3, 3]$.

³The most general solution of the differential equation is $f(t) = [1/2] \cos t + [1/2] \sin t + C \cdot e^{-t}$. It requires additional techniques to find this solution, and we shall not treat them at this time.

5. Suppose that a thin metal heat-conducting plate is in the shape of a round disc and has radius 1. Imagine that the upper half of the circular boundary of the plate is held at constant temperature 5° and the lower half of the circular boundary is held at constant temperature -3° . Describe the steady state heat distribution on the entire plate.
6. Suppose that a thin metal heat-conducting plate is in the shape of a round disc and has radius 1. Imagine that the upper half of the circular boundary of the plate is held at constant temperature 8° and the lower half of the circular boundary is held at constant temperature 0° . Describe the steady state heat distribution on the entire plate.
7. Use Fourier series to solve the differential equation

$$f' - f = \sin t.$$

10.2 The Fourier Transform

The Fourier transform is the analogue on the real line of Fourier series coefficients for a function on $[0, 2\pi)$. For deep reasons (which are explained in [FOL]), the Fourier series on the bounded interval $[0, 2\pi)$ must be replaced by the continuous analogue of a sum, which is an integral. In this section we will learn what the Fourier transform is, and what the basic convergence question about the Fourier transform is. Then we will see how complex variable techniques may be used in the study of the Fourier transform.

10.2.1 Basic Definitions

The Fourier transform takes place on the real line \mathbb{R} . If f is an integrable function on \mathbb{R} , then we *define*

$$\widehat{f}(\xi) = \int f(t)e^{-2\pi it \cdot \xi} dt. \quad (10.35)$$

The variable t is called the “space variable” and the variable ξ is called the “Fourier transform variable” (or sometimes the “phase variable”). There are many variants of this definition. Some tracts replace $-2\pi it \cdot \xi$ in the exponential with $+2\pi it \cdot \xi$. Others omit the factor of 2π . We have chosen this particular definition because it simplifies certain basic formulas in the

subject. The reader should be well aware of these possible discrepancies, for different tables of Fourier transforms will use different definitions of the transform. Those who want to learn the full story of the theory of the Fourier transform should consult [FOL] or [KRA1] or [STW].

The Fourier transform \widehat{f} of an integrable function f enjoys the property that \widehat{f} is continuous and vanishes at infinity. However, \widehat{f} need not be integrable. In fact, \widehat{f} can die arbitrarily slowly at infinity. This fact of life necessitates extra care in formulating results about the Fourier transform and its inverse.

Recall that we recover a function on $[0, 2\pi)$ from its sequence of Fourier coefficients by calculating a *sum*. In the theory of the Fourier transform, we recover f from \widehat{f} by calculating an integral. Namely, if g is any integrable function on the real line \mathbb{R} , then we define

$$\check{g}(t) = \int g(\xi) e^{2\pi i \xi t} d\xi. \quad (10.36)$$

The operation $\check{}$ is called the *inverse Fourier transform*.

It turns out that, whenever the integrals in question make sense, the Fourier operations $\check{}$ and $\widehat{}$ are inverse to each other. More precisely, if f is a function on the real line such that

- f is integrable,
- \widehat{f} is integrable,

then

$$\check{\widehat{f}} = f. \quad (10.37)$$

An easily verified hypothesis that will guarantee that both f and \widehat{f} are integrable is that $f \in C^2$ and f, f', f'' are integrable.

10.2.2 Some Fourier Transform Examples That Use Complex Variables

EXAMPLE 57 Let us calculate the Fourier transform of the function

$$f(t) = \frac{1}{1+t^2}. \quad (10.38)$$

□

Solution: The Fourier integral is

$$\widehat{f}(\xi) = \int_{-\infty}^{\infty} \frac{1}{1+t^2} e^{-2\pi i t \cdot \xi} dt. \quad (10.39)$$

We will evaluate the integral using the calculus of residues.

For fixed ξ in \mathbb{R} , we thus consider the meromorphic function

$$m(z) = \frac{e^{-2\pi i z \cdot \xi}}{1+z^2}, \quad (10.40)$$

which has poles at $\pm i$.

For the case $\xi \geq 0$ it is convenient to use as contour of integration the positively oriented semicircle γ_R of radius $R > 1$ in the lower half-plane that is shown in Figure 10.4. Of course this contour only contains the pole at $-i$. We find that

$$\begin{aligned} 2\pi i \operatorname{Res}_m(-i) &= \int_{\gamma_R} m(z) dz \\ &= \int_{\gamma_R^1} m(z) dz + \int_{\gamma_R^2} m(z) dz. \end{aligned} \quad (10.41)$$

The integral over γ_R^1 vanishes as $R \rightarrow +\infty$ and the integral over γ_R^2 tends to

$$- \int_{-\infty}^{\infty} \frac{1}{1+t^2} e^{-2\pi i t \cdot \xi} dt. \quad (10.42)$$

It is straightforward to calculate that

$$\begin{aligned} \operatorname{Res}_m(-i) &= \lim_{z \rightarrow -i} (z - (-i)) \cdot \frac{e^{-2\pi i \xi z}}{z^2 + 1} \\ &= \left. \frac{e^{-2\pi i \xi z}}{z - i} \right|_{z=-i} \\ &= \frac{e^{-2\pi i \xi (-i)}}{-2i} \\ &= \frac{e^{-2\pi \xi}}{-2i}. \end{aligned} \quad (10.43)$$

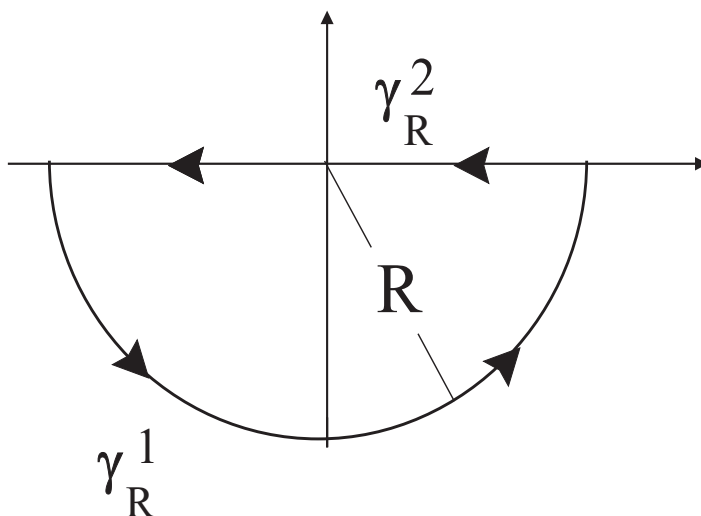


Figure 10.4: A positively oriented semicircle γ_R in the lower half-plane.

Thus

$$2\pi i \operatorname{Res}_m(-i) = -\pi e^{-2\pi\xi}. \quad (10.44)$$

We conclude that

$$\widehat{f}(\xi) = \int_{-\infty}^{\infty} \frac{1}{1+t^2} e^{-2\pi i t \cdot \xi} dt = \pi e^{-2\pi\xi}. \quad (10.45)$$

A similar calculation, using the contour ν_R shown in Figure 10.5, shows that, when $\xi < 0$, then

$$\widehat{f}(\xi) = \pi e^{2\pi\xi}. \quad (10.46)$$

In summary, for any $\xi \in \mathbb{R}$,

$$\widehat{f}(\xi) = \pi e^{-2\pi|\xi|}. \quad (10.47)$$

We can now check our work using the inverse Fourier transform: We observe that both f and \widehat{f} are integrable, so we calculate that

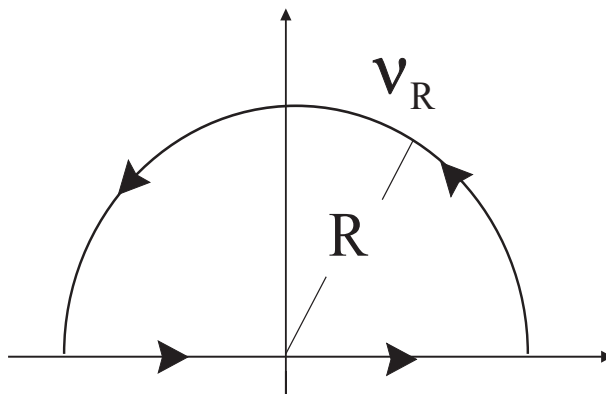


Figure 10.5: A positively oriented semicircle in the upper half-plane.

$$\begin{aligned}
 \widehat{f}(t) &= \int_{-\infty}^{\infty} \widehat{f} e^{2\pi i \xi \cdot t} d\xi \\
 &= \int_0^{\infty} \pi e^{-2\pi \xi} e^{2\pi i \xi t} d\xi + \int_{-\infty}^0 \pi e^{2\pi \xi} e^{2\pi i \xi t} d\xi \\
 &= \int_0^{\infty} \pi e^{-2\pi \xi} e^{2\pi i \xi t} d\xi + \int_0^{\infty} \pi e^{-2\pi \xi} e^{-2\pi i \xi t} d\xi \\
 &= 2\operatorname{Re} \left[\int_0^{\infty} \pi e^{-2\pi \xi} e^{2\pi i \xi t} d\xi \right] \\
 &= 2\operatorname{Re} \left[\int_0^{\infty} \pi e^{\xi(-2\pi+2\pi i t)} d\xi \right] \\
 &= \operatorname{Re} \left[\frac{2\pi}{-2\pi+2\pi i t} \cdot e^{\xi(-2\pi+2\pi i t)} \right]_{\xi=0}^{\xi=\infty} \\
 &= \operatorname{Re} \left[\frac{1}{-1+it} \cdot (0-1) \right] \\
 &= \frac{1}{1+t^2}. \tag{10.48}
 \end{aligned}$$

Observe that our calculations confirm the correctness of our Fourier transform determination. In addition, they demonstrate the validity of the Fourier

inversion formula in a particular instance. \square

EXAMPLE 58 Physicists call a function of the form

$$f(t) = \begin{cases} \cos 2\pi t & \text{if } -7/4 \leq t \leq 7/4 \\ 0 & \text{if } t < -7/4 \text{ or } t > 7/4 \end{cases} \quad (10.49)$$

a *finite wave train*. Let us calculate the Fourier transform of this function.

\square

Solution: The Fourier integral is

$$\begin{aligned} \widehat{f}(\xi) &= \int_{-\infty}^{\infty} f(t)e^{-2\pi i\xi \cdot t} dt \\ &= \int_{-7/4}^{7/4} (\cos 2\pi t)e^{-2\pi i\xi \cdot t} dt \\ &= \frac{1}{2} \left[\int_{-7/4}^{7/4} e^{2\pi i t} e^{-2\pi i\xi \cdot t} dt + \int_{-7/4}^{7/4} e^{-2\pi i t} e^{-2\pi i\xi \cdot t} dt \right] \\ &= \frac{1}{2} \left[\int_{-7/4}^{7/4} e^{(2\pi i - 2\pi i\xi)t} dt + \int_{-7/4}^{7/4} e^{(-2\pi i - 2\pi i\xi)t} dt \right] \\ &= \frac{1}{2} \left(\left[\frac{1}{2\pi i - 2\pi i\xi} e^{(2\pi i - 2\pi i\xi)t} \right]_{t=-7/4}^{t=7/4} \right. \\ &\quad \left. + \left[\frac{1}{-2\pi i - 2\pi i\xi} e^{(-2\pi i - 2\pi i\xi)t} \right]_{t=-7/4}^{t=7/4} \right) \\ &= \frac{1}{2} \left\{ \frac{1}{2\pi i(1-\xi)} \left[e^{2\pi i(1-\xi)[7/4]} - e^{2\pi i(1-\xi)[-7/4]} \right] \right. \\ &\quad \left. + \frac{1}{2\pi i(-1-\xi)} \left[e^{-2\pi i(1+\xi)[7/4]} - e^{-2\pi i(1+\xi)[-7/4]} \right] \right\} \end{aligned}$$

$$\begin{aligned}
&= \frac{1}{2} \left\{ \frac{1}{2\pi i(1-\xi)} 2i \sin\left(\frac{7\pi}{2}(1-\xi)\right) \right. \\
&\quad \left. - \frac{1}{2\pi i(-1-\xi)} 2i \sin\left(\frac{7\pi}{2}(1+\xi)\right) \right\} \\
&= \frac{1}{2\pi(1-\xi)} \left[\sin\frac{7\pi}{2} \cos\frac{7\pi}{2}\xi - \cos\frac{7\pi}{2} \sin\frac{7\pi}{2}\xi \right] \\
&\quad - \frac{1}{2\pi(-1-\xi)} \left[\sin\frac{7\pi}{2} \cos\frac{7\pi}{2}\xi + \cos\frac{7\pi}{2} \sin\frac{7\pi}{2}\xi \right] \\
&= \frac{1}{2\pi(1-\xi)} \left(-\cos\frac{7\pi}{2}\xi \right) + \frac{1}{2\pi(1+\xi)} \left(-\cos\frac{7\pi}{2}\xi \right) \\
&= \frac{1}{2\pi} \cos\frac{7\pi}{2}\xi \left\{ \frac{-1}{1+\xi} - \frac{1}{1-\xi} \right\} \\
&= -\frac{1}{\pi} \left(\cos\frac{7\pi}{2}\xi \right) \frac{1}{1-\xi^2}. \tag{10.50}
\end{aligned}$$

In summary,

$$\widehat{f}(\xi) = -\frac{1}{\pi} \cos\left(\frac{7\pi}{2}\xi\right) \frac{1}{1-\xi^2}. \tag{10.51}$$

We may now perform a calculation to confirm the Fourier inversion formula in this example. The calculus of residues will prove to be a useful tool in the process.

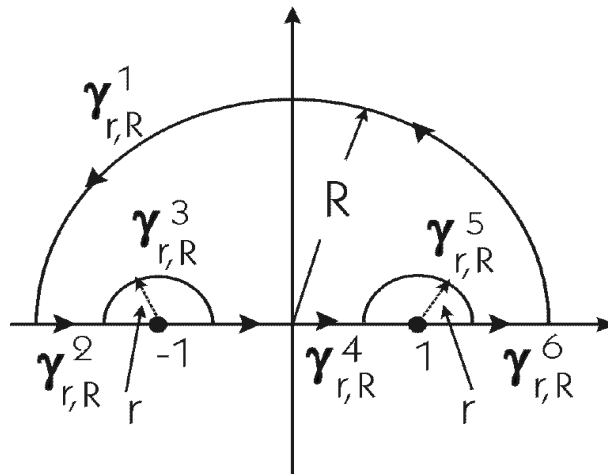
Now

$$\begin{aligned}
\check{f}(t) &= -\frac{1}{\pi} \int_{-\infty}^{\infty} \frac{1}{1-\xi^2} \cos\frac{7\pi}{2}\xi \cdot e^{2\pi i\xi t} d\xi \\
&= -\frac{1}{2\pi} \int_{-\infty}^{\infty} \frac{1}{1-\xi^2} \left[e^{(7\pi/2)\xi i} + e^{-(7\pi/2)\xi i} \right] e^{2\pi i\xi t} d\xi \\
&= -\frac{1}{2\pi} \int_{-\infty}^{\infty} \frac{1}{1-\xi^2} e^{i\xi[(7\pi/2)+2\pi t]} d\xi \\
&\quad - \frac{1}{2\pi} \int_{-\infty}^{\infty} \frac{1}{1-\xi^2} e^{i\xi[(-7\pi/2)+2\pi t]} d\xi \\
&\equiv I + II. \tag{10.52}
\end{aligned}$$

First we analyze expression I . For $t \geq -7/4$ fixed, the expression $(7\pi/2) + 2\pi t$ is nonnegative. Thus the exponential expression will be bounded (that is, the real part of the exponent will be nonpositive), if we integrate the meromorphic function

$$\frac{1}{1 - z^2} e^{iz[(7\pi/2) + 2\pi t]} \tag{10.53}$$

on the curve $\gamma_{r,R}$ exhibited in Figure 10.2.2. It is easy to see that the integral over $\gamma_{r,R}^1$ tends to zero as $R \rightarrow +\infty$. And the integrals over $\gamma_{r,R}^2, \gamma_{r,R}^4, \gamma_{r,R}^6$ tend to the integral that is I as $r \rightarrow 0$. It remains to evaluate the integrals over $\gamma_{r,R}^3$ and $\gamma_{r,R}^5$. We do the first and leave the second for the reader.



The curve $\gamma_{r,R}$.

Now

$$\begin{aligned}
& -\frac{1}{2\pi} \oint_{\gamma_{r,R}^3} \frac{1}{1-z^2} e^{iz[(7\pi/2)+2\pi t]} dz \\
&= -\frac{1}{2\pi} \int_{\pi}^0 \frac{1}{1-(-1+re^{i\theta})^2} e^{i(-1+re^{i\theta})[(7\pi/2)+2\pi t]} ire^{i\theta} d\theta \\
&= -\frac{1}{2\pi} \int_{\pi}^0 \frac{ire^{i\theta}}{2re^{i\theta}-r^2e^{2i\theta}} e^{i(-1+re^{i\theta})[(7\pi/2)+2\pi t]} d\theta \\
&= -\frac{i}{2\pi} \int_{\pi}^0 \frac{1}{2-re^{i\theta}} e^{i(-1+re^{i\theta})[(7\pi/2)+2\pi t]} d\theta \\
&\xrightarrow{(r \rightarrow 0)} -\frac{i}{2\pi} \int_{\pi}^0 \frac{1}{2} e^{-i[(7\pi/2)+2\pi t]} d\theta \\
&= -\frac{1}{4} e^{-2\pi it}. \tag{10.54}
\end{aligned}$$

A similar calculation shows that

$$-\frac{1}{2\pi} \oint_{\gamma_{r,R}^5} \frac{1}{1-z^2} e^{iz[(7\pi/2)+2\pi t]} dz = -\frac{1}{4} e^{2\pi it}. \tag{10.55}$$

In sum,

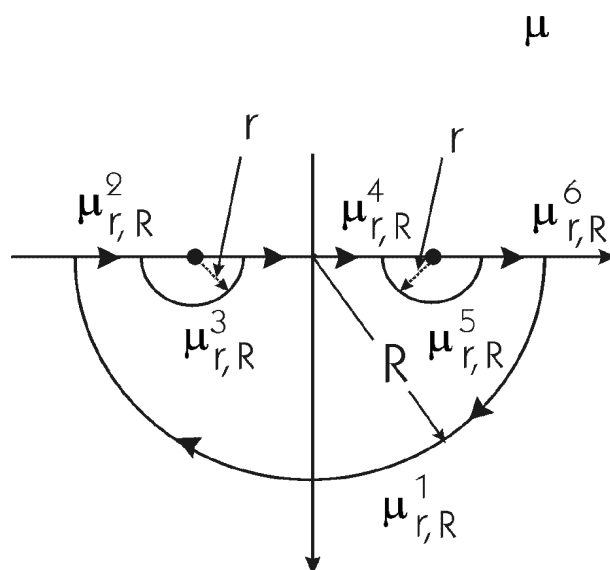
$$I = \frac{1}{2\pi} \oint_{\gamma_{r,R}^3} + \frac{1}{2\pi} \oint_{\gamma_{r,R}^5} = -\frac{1}{2} \cos 2\pi t. \tag{10.56}$$

To analyze the integral II , we begin by fixing $t > 7/4$. Then we will have $(-7\pi/2) + 2\pi t > 0$. If we again use the contour in Figure 10.2.2, then the exponential in the meromorphic function

$$\frac{1}{1-z^2} e^{iz[(-7\pi/2)+2\pi t]} \tag{10.57}$$

will be bounded on the curve $\gamma_{r,R}^1$. Of course the integral over $\gamma_{r,R}^1$ tends to zero as $R \rightarrow +\infty$. The integrals over $\gamma_{r,R}^2, \gamma_{r,R}^4, \gamma_{r,R}^6$ in sum tend to the integral that defines II . Finally, a calculation that is nearly identical to the one that we just performed for I shows that

$$-\frac{1}{2\pi} \oint_{\gamma_{r,R}^3} \frac{1}{1-z^2} e^{iz[(-7\pi/2)+2\pi t]} dz = \frac{1}{4} e^{-2\pi it}. \tag{10.58}$$

Figure 10.6: The curve $\nu_{r,R}$.

Similarly,

$$-\frac{1}{2\pi} \oint_{\gamma_{r,R}^5} \frac{1}{1-z^2} e^{iz[(-7\pi/2)+2\pi t]} dz = \frac{1}{4} e^{-2\pi it}. \quad (10.59)$$

Therefore

$$II = \frac{1}{2} \cos 2\pi t. \quad (10.60)$$

In summary, we see that on the common domain $t > 7/4$ we have

$$I + II = -\frac{1}{2} \cos 2\pi t + \frac{1}{2} \cos 2\pi t = 0. \quad (10.61)$$

This value agrees with $f(t)$ when $t > 7/4$.

Similar calculations for $t < -7/4$ (but using the contour shown in Figure 10.6) show that

$$\widehat{f}(t) = 0. \quad (10.62)$$

The remaining, and most interesting, calculation is for $-7/4 \leq t \leq 7/4$. We have already calculated I for that range of t . To calculate II , we use the

contour in Figure 10.6. The result is that

$$II = -\frac{1}{2} \cos 2\pi t. \quad (10.63)$$

Therefore

$$\widehat{f}(t) = -(I + II) = \frac{1}{2} \cos 2\pi t + \frac{1}{2} \cos 2\pi t = \cos 2\pi t. \quad (10.64)$$

This confirms Fourier inversion for the finite wave train. \square

10.2.3 Solving a Differential Equation Using the Fourier Transform

Suppose that $f \in C^1(\mathbb{R})$ and that both f and f' are integrable. Then

$$\begin{aligned} \widehat{f}'(\xi) &= \int_{-\infty}^{\infty} f'(t) e^{-2\pi i t \xi} dt \\ &= f(t) e^{-2\pi i t \xi} \Big|_{-\infty}^{\infty} + 2\pi i \xi \int_{-\infty}^{\infty} f(t) e^{-2\pi i t \xi} dt. \end{aligned}$$

The fact that f, f' are integrable guarantees that the boundary term vanishes. We conclude that

$$\widehat{f}'(\xi) = 2\pi i \xi \widehat{f}(\xi). \quad (10.65)$$

This formula is elementary but important. It is analogous to formula (10.33) for Fourier series coefficients. We can use it to solve a differential equation:

EXAMPLE 59 Use the Fourier transform to solve the differential equation

$$f''(t) - f(t) = \varphi(t), \quad (10.66)$$

where

$$\varphi(t) = \begin{cases} e^{-t} & \text{if } t > 0 \\ 0 & \text{if } t \leq 0. \end{cases} \quad (10.67)$$

\square

Solution: We begin by applying the Fourier transform to both sides of equation (10.66). The result is

$$-4\pi^2\xi^2\widehat{f}(\xi) - \widehat{f}(\xi) = \widehat{\varphi}. \quad (10.68)$$

An easy calculation shows that

$$\widehat{\varphi}(\xi) = -\frac{1}{1 + 2\pi i\xi}. \quad (10.69)$$

Thus, under the Fourier transform, our ordinary differential equation has become

$$-4\pi^2\xi^2\widehat{f}(\xi) - \widehat{f}(\xi) = -\frac{1}{1 + 2\pi i\xi} \quad (10.70)$$

or

$$\widehat{f}(\xi) = \frac{1}{(4\pi^2\xi^2 + 1)(1 + 2\pi i\xi)}. \quad (10.71)$$

Of course the expression on the right-hand side of (10.71) has no singularities on the real line (thanks to complex variables) and is integrable. So we may apply the Fourier inversion formula to both sides of (10.71) to obtain

$$f(t) = \check{\widehat{f}}(t) = \left(\frac{1}{(4\pi^2\xi^2 + 1)(1 + 2\pi i\xi)} \right)^\vee. \quad (10.72)$$

We can find the function f if we can evaluate the expression on the right-hand side of (10.72). This amounts to calculating the integral

$$\int_{-\infty}^{\infty} \frac{1}{(4\pi^2\xi^2 + 1)(1 + 2\pi i\xi)} e^{2\pi i\xi t} d\xi. \quad (10.73)$$

We will do so for $t > 0$ (the most interesting set of values for t , given the data function φ in the differential equation) and let the reader worry about $t \leq 0$.

It is helpful to use the calculus of residues to evaluate the integral in (10.73). We use the contour in Figure 10.6, chosen (with $R \gg 1$) so that the exponential in the integrand will be bounded when the variable is on the curve and $t > 0$. The pole of

$$m(z) = \frac{1}{(4\pi^2z^2 + 1)(1 + 2\pi iz)} e^{2\pi izt} = \frac{1}{(1 - 2\pi iz)(1 + 2\pi iz)^2} e^{2\pi izt} \quad (10.74)$$

that lies inside of γ_R is at $P = i/[2\pi]$. This is a pole of order two. We use the formula in Section 4.4. The result is that

$$\operatorname{Res}_m(P) = \frac{-i}{4\pi} \left[\frac{1}{2}e^{-t} + te^{-t} \right]. \quad (10.75)$$

As usual, the value of the integral

$$\int_{-\infty}^{\infty} \frac{1}{(4\pi^2\xi^2 + 1)(1 + 2\pi i\xi)} e^{2\pi i\xi t} d\xi \quad (10.76)$$

is

$$(-2\pi i) \cdot \frac{-i}{4\pi} \left[\frac{1}{2}e^{-t} + te^{-t} \right] = -\frac{1}{2} \left[\frac{1}{2}e^{-t} + te^{-t} \right]. \quad (10.77)$$

This is the solution f (at least when $t > 0$) of our differential equation (10.66). \square

Exercises

1. Use complex analysis to calculate the Fourier transform of the function $f(t) = 1/[1 - it^2]$.

2. Calculate the Fourier transform of the function

$$f(t) = \begin{cases} \sin \pi t & \text{if } -2 \leq t \leq 2 \\ 0 & \text{if } t < -2 \text{ or } t > 2 \end{cases}$$

3. Use the Fourier transform to solve the differential equation

$$f''(t) + f(t) = \psi(t),$$

where

$$\psi(t) = \begin{cases} 1 & \text{if } -1 \leq t \leq 0 \\ 0 & \text{if } t > 0. \end{cases}$$

4. Let \mathcal{F} denote the Fourier transform. Verify that \mathcal{F}^4 is the identity operator. What can you say about the eigenvalues of the Fourier transform?

10.3 The Laplace Transform

10.3.1 Prologue

Let f be an integrable function on the half-line $\{t \in \mathbb{R} : t \geq 0\}$. [We implicitly assume that $f(t) = 0$ when $t < 0$.]

In many contexts, it is convenient to think of the Fourier transform

$$\widehat{f}(\xi) = \int f(t)e^{-2\pi i\xi \cdot t} dt \quad (10.78)$$

as a function of the complex variable ξ . In fact when $\text{Im}\xi < 0$ and $t > 0$ the exponent in the integrand has negative real part so the exponential is bounded and the integral converges. For suitable f one can verify, using Morera's theorem (Section 3.1.1) for instance, that $\widehat{f}(\xi)$ is a *holomorphic* function of ξ . It is particularly convenient to let ξ be pure imaginary: the customary notation is $\xi = -is/(2\pi)$ for $s \geq 0$. Then we have defined a new function

$$F(s) = \int f(t)e^{-st} dt. \quad (10.79)$$

We call F the *Laplace transform* of f . Sometimes, instead of writing F , we write $\mathcal{L}(f)$.

The Laplace transform is a useful tool because

- It has formal similarities to the Fourier transform.
- It can be applied to a larger class of functions than the Fourier transform (since e^{-st} decays rapidly at infinity).
- It is often straightforward to compute.

The lesson here is that it is sometimes useful to modify a familiar mathematical operation (in this case the Fourier transform) by letting the variable be complex (in this case producing the Laplace transform).

We now provide just one example to illustrate the utility of the Laplace transform.

10.3.2 Solving a Differential Equation Using the Laplace Transform

EXAMPLE 60 Use the Laplace transform to solve the ordinary differential equation

$$f''(t) + 3f'(t) + 2f(t) = \sin t \quad (10.80)$$

subject to the initial conditions $f(0) = 1$, $f'(0) = 0$. \square

Solution: Working by analogy with Example 59, we calculate the Laplace transform of both sides of the equation. Integrating by parts (as we did when studying the Fourier transform—Section 10.2.2), we can see that

$$\mathcal{L}(f')(s) = s \cdot \mathcal{L}f(s) - 1 \quad (10.81)$$

and

$$\mathcal{L}(f'')(s) = s^2 \mathcal{L}f(s) - s. \quad (10.82)$$

(These formulas are correct when all the relevant integrals converge. See also the Table of Laplace Transforms on page 290.)

Thus equation (10.80) is transformed to

$$[s^2 \mathcal{L}f(s) - s] + 3[s \cdot \mathcal{L}f(s) - 1] + 2\mathcal{L}f(s) = (\mathcal{L}[\sin t])(s). \quad (10.83)$$

A straightforward calculation (using either integration by parts or complex variable methods—or see the Table) shows that

$$\mathcal{L}[\sin t](s) = \frac{1}{s^2 + 1}. \quad (10.84)$$

So equation (10.83) becomes

$$[s^2 \mathcal{L}f(s) - s] + 3[s \cdot \mathcal{L}f(s) - 1] + 2\mathcal{L}f(s) = \frac{1}{s^2 + 1}. \quad (10.85)$$

Just as with the Fourier transform, the Laplace transform has transformed the differential equation to an algebraic equation. We find that

$$\mathcal{L}f(s) = \frac{1}{s^2 + 3s + 2} \cdot \left[\frac{1}{s^2 + 1} + s + 3 \right]. \quad (10.86)$$

We use the method of partial fractions to break up the right-hand side into simpler components. The result is

$$\mathcal{L}f(s) = \frac{5/2}{s+1} + \frac{-6/5}{s+2} + \frac{-3s/10 + 1/10}{s^2 + 1}. \quad (10.87)$$

Now our job is to find the inverse Laplace transform of each expression on the right. One way to do this is by using the Laplace inversion formula

$$f(t) = \int_{-i\infty}^{\infty} F(s)e^{st} ds. \quad (10.88)$$

However, the most common method is to use a Table of Laplace Transforms, as in [SASN, p. 402] or [ZWI, pp. 559–564] or the Table of Laplace transforms on page 290 of this book. From such a table, we find that

$$f(t) = \frac{5}{2}e^{-t} - \frac{6}{5}e^{-2t} - \frac{3}{10}\cos t + \frac{1}{10}\sin t. \quad (10.89)$$

The reader may check that this is indeed a solution to the differential equation (10.80). \square

10.4 A Table of Laplace Transforms

On the next page we record some useful Laplace transforms. Each of these may be calculated with elementary techniques of integration.

Exercises

1. Calculate the Laplace transform of each of these functions.

- (a) $f(t) = t^2$
- (b) $g(t) = \sin 2t$
- (c) $h(t) = \cos 3t$
- (d) $f(t) = e^{4t}$
- (e) $g(t) = t \cos 4t$
- (f) $h(t) = e^{-t} \sin t$

TABLE OF LAPLACE TRANSFORMS

Function	Laplace Transform	Domain of Convergence
e^{at}	$\frac{1}{s-a}$	$\{s : \operatorname{Re} s > \operatorname{Re} a\}$
1	$\frac{1}{s}$	$\{s : \operatorname{Re} s > 0\}$
$\cos \omega t$	$\frac{s}{s^2 + \omega^2}$	w real, $\{s : \operatorname{Re} s > 0\}$
$\sin \omega t$	$\frac{\omega}{s^2 + \omega^2}$	w real, $\{s : \operatorname{Re} s > 0\}$
$\cosh \omega t$	$\frac{s}{s^2 - \omega^2}$	w real, $\{s : \operatorname{Re} s > \omega \}$
$\sinh \omega t$	$\frac{\omega}{s^2 - \omega^2}$	ω real, $\{s : \operatorname{Re} s > \omega \}$
$e^{-\lambda t} \cos \omega t$	$\frac{s+\lambda}{(s+\lambda)^2 + \omega^2}$	ω, λ real, $\{s : \operatorname{Re} s > -\lambda\}$
$e^{-\lambda t} \sin \omega t$	$\frac{\omega}{(s+\lambda)^2 + \omega^2}$	ω, λ real, $\{s : \operatorname{Re} s > -\lambda\}$
$t^n e^{at}$	$\frac{n!}{(s-a)^{n+1}}$	$\{s : \operatorname{Re} s > \operatorname{Re} a\}$
t^n	$\frac{n!}{s^{n+1}}$	$\{s : \operatorname{Re} s > 0\}$
$t \cos \omega t$	$\frac{s^2 - \omega^2}{(s^2 + \omega^2)^2}$	ω real, $\{s : \operatorname{Re} s > 0\}$
$t \sin \omega t$	$\frac{2\omega s}{(s^2 + \omega^2)^2}$	ω real, $\{s : \operatorname{Re} s > 0\}$
$f'(t)$	$s\mathcal{L}f(s) - f(0)$	$\{s : \operatorname{Re} s > 0\}$
$f''(t)$	$s^2\mathcal{L}f(s) - sf(0) - f'(0)$	$\{s : \operatorname{Re} s > 0\}$
$tf(t)$	$-(\mathcal{L}f)'(s)$	$\{s : \operatorname{Re} s > 0\}$
$e^{at}f(t)$	$\mathcal{L}f(s-a)$	$\{s : \operatorname{Re} s > 0\}$

2. Use the Laplace transform to solve the differential equation

$$f'' - 2f' + f = \cos t.$$

3. Solve the differential equation

$$f'' + 3f = e^t.$$

4. Solve the differential equation

$$f'' - f' = \sin t.$$

10.5 The z -Transform

The z -transform, under that particular name, is more familiar in the engineering community than in the mathematics community. Mathematicians group this circle of ideas with the notion of generating function and with allied ideas from finite and combinatorial mathematics (see, for instance [STA]). Here we give a quick introduction to the z -transform and its uses.

10.5.1 Basic Definitions

Let $\{a_n\}_{n=-\infty}^{+\infty}$ be a doubly infinite sequence. The z -transform of this sequence is defined to be the series

$$A(z) = \sum_{n=-\infty}^{\infty} a_n z^{-n}. \quad (10.90)$$

If this series converges on some annulus centered at the origin, then of course it defines a holomorphic function on that annulus. Often the properties of the original sequence $\{a_n\}_{n=-\infty}^{+\infty}$ can be studied by way of the holomorphic function A .

The reference [ZWI, pp. 231, 543] explains the relationship between the z -transform and other transforms that we have discussed. The reference [HEN, v. 2, pp. 322, 327, 332, 334, 335, 336, 350] gives further instances of the technique of the z -transform.

10.5.2 Population Growth by Means of the z -Transform

We present a typical example of the use of the z -transform.

EXAMPLE 61 During a period of growth, a population of salmon has the following two properties:

(10.91) The population, on average, reproduces at the rate of 3% per month.

(10.92) One hundred new salmon swim upstream and join the population each month.

If $a(n)$ is the population in month n , then find a formula for $a(n)$. \square

Solution: Let P denote the initial population. Then we may describe the sequence in this recursive manner:

$$\begin{aligned} a(0) &= P \\ a(1) &= a(0) \cdot (1 + .03) + 100 \\ a(2) &= a(1) \cdot (1 + .03) + 100 \\ &\text{etc.} \end{aligned} \tag{10.93}$$

Because we are going to use the theory of the z -transform, it is convenient to postulate that $a(n) = 0$ for $n < 0$.

Let us assume that $\{a(n)\}$ has a z -transform $A(z)$ —at least when z is sufficiently large. It is also convenient to think of each part of the recursion as depending on n . So let us set

$$P(n) = \begin{cases} P & \text{if } n = -1 \\ 0 & \text{if } n \neq -1 \end{cases} \tag{10.94}$$

and

$$s(n) = \begin{cases} 100 & \text{if } n \geq 0 \\ 0 & \text{if } n < 0. \end{cases} \tag{10.95}$$

Then our recursion can be expressed as

$$a(n+1) = 1.03a(n) + P(n) + s(n). \tag{10.96}$$

We multiply both sides of this equation by z^{-n} and sum over n to obtain

$$\sum_n a(n+1)z^{-n} = 1.03 \sum_n a(n)z^{-n} + \sum_n P(n)z^{-n} + \sum_n s(n)z^{-n} \quad (10.97)$$

or

$$z \cdot A(z) = 1.03A(z) + Pz + \frac{100z}{z-1}. \quad (10.98)$$

Here, for the last term, we have used the elementary fact that

$$\sum_{n=0}^{\infty} z^{-n} = \sum_{n=0}^{\infty} (1/z)^n = \frac{1}{1-1/z} = \frac{z}{z-1}, \quad (10.99)$$

valid for $|z| > 1$.

Rearranging equation (10.98), we find that

$$A(z) = \frac{Pz^2 + (100 - P)z}{(z-1)(z-1.03)} = z \cdot \frac{Pz + (100 - P)}{(z-1)(z-1.03)}, \quad (10.100)$$

valid for $|z|$ sufficiently large.

Of course we may decompose this last expression for $A(z)$ into a partial fractions decomposition:

$$A(z) = z \cdot \left[\frac{P + 100/.03}{z - 1.03} - \frac{100/.03}{z - 1} \right]. \quad (10.101)$$

We rewrite the terms in preparation of making a Laurent expansion:

$$A(z) = \left(P + \frac{100}{.03} \right) \cdot \left[\frac{1}{1 - 1.03/z} \right] - \frac{100}{.03} \cdot \frac{1}{1 - 1/z}. \quad (10.102)$$

For $|z| > 1.03$, we may use the standard expansion

$$\frac{1}{1 - \alpha} = \sum_{n=0}^{\infty} \alpha^n, \quad |\alpha| < 1 \quad (10.103)$$

to obtain

$$A(z) = \left(P + \frac{100}{.03} \right) \sum_{n=0}^{\infty} (1.03)^n z^{-n} - \frac{100}{.03} \sum_{n=0}^{\infty} z^{-n}. \quad (10.104)$$

Note that we have obtained the expansion of $A(z)$ as a z -series! Its coefficients must therefore be the $a(n)$. We conclude that

$$a(n) = \begin{cases} \left(P + \frac{100}{.03}\right) (1.03)^n - \frac{100}{.03} & \text{if } n \geq 0 \\ 0 & \text{if } n < 0. \end{cases} \quad (10.105)$$

It is easy to see that this problem could have been solved without the aid of the z -transform. But the z -transform was a useful device for keeping track of information. \square

Exercises

1. A population of *drosophila melanogaster* reproduces at the rate of 5% per month. Also 50 new flies join the population from other areas each month. If $b(n)$ is the population in month n , then find a formula for $b(n)$.
2. A population of dodo birds dies off at the rate of 3% per month. In addition, twenty birds leave the population each month out of sheer disgust. Use the z -transform to model this population.

Chapter 11

Partial Differential Equations (PDEs) and Boundary Value Problems

11.1 Fourier Methods in the Theory of Differential Equations

In fact an entire separate book could be written about the applications of Fourier analysis to differential equations and to other parts of mathematical analysis. The subject of Fourier series grew up hand in hand with the analytical areas to which it is applied. In the present brief section we merely indicate a couple of examples.

11.1.1 Remarks on Different Fourier Notations

In Section 10.1, we found it convenient to define the Fourier coefficients of an integrable function on the interval $[0, 2\pi)$ to be

$$\widehat{f}(n) = \frac{1}{2\pi} \int_0^{2\pi} f(x)e^{-inx} dx.$$

From the point of view of pure mathematics, this complex notation has proved to be useful, and it has become standardized.

But, in applications, there are other Fourier paradigms. They are easily seen to be equivalent to the one we have already introduced. The reader

who wants to be conversant in this subject should be aware of these different ways of writing the basic ideas of Fourier series. We will introduce one of them now, and use it in the ensuing discussion.

If f is integrable on the interval $[-\pi, \pi)$ (note that, by 2π -periodicity, this is not essentially different from $[0, 2\pi)$), then we define the Fourier coefficients

$$a_0 = \frac{1}{2\pi} \int_{-\pi}^{\pi} f(x) dx,$$

$$a_n = \frac{1}{\pi} \int_{-\pi}^{\pi} f(x) \cos nx dx \quad \text{for } n \geq 1,$$

$$b_n = \frac{1}{\pi} \int_{-\pi}^{\pi} f(x) \sin nx dx \quad \text{for } n \geq 1.$$

This new notation is not essentially different from the old, for

$$\widehat{f}(n) = \frac{1}{2} [a_n + ib_n]$$

for $n \neq 0$ and $\widehat{f}(0) = a_0$. The change in normalization (that is, whether the constant before the integral is $1/\pi$ or $1/2\pi$) is dictated by the observation that we want to exploit the fact (so that our formulas come out in a neat and elegant fashion) that

$$\frac{1}{2\pi} \int_0^{2\pi} |e^{-int}|^2 dt = 1,$$

in the theory from Section 11.2 and that

$$\frac{1}{2\pi} \int_{-\pi}^{\pi} 1^2 dx = 1,$$

$$\frac{1}{\pi} \int_{-\pi}^{\pi} |\cos nt|^2 dt = 1 \quad \text{for } n \geq 1,$$

$$\frac{1}{\pi} \int_{-\pi}^{\pi} |\sin nt|^2 dt = 1 \quad \text{for } n \geq 1$$

in the theory that we are about to develop.

It is clear that any statement (as in Section 10.1) that is formulated in the language of $\widehat{f}(n)$ is easily translated into the language of a_n and b_n and vice versa. In the present discussion we shall use a_n and b_n just because that is the custom in applied mathematics, and because it is convenient for the points that we want to make.

11.1.2 The Dirichlet Problem on the Disc

We now repeat some of the ideas from Chapter 9 in our new context. We shall study the two-dimensional Laplace equation, which is

$$\Delta = \frac{\partial^2 u}{\partial x^2} + \frac{\partial^2 u}{\partial y^2} = 0. \quad (11.1)$$

This is probably the most important differential equation of mathematical physics. It describes a steady state heat distribution, electrical fields, and many other important phenomena of nature.

It will be useful for us to write this equation in polar coordinates. To do so, recall that

$$r^2 = x^2 + y^2, \quad x = r \cos \theta, \quad y = r \sin \theta.$$

Thus

$$\begin{aligned} \frac{\partial}{\partial r} &= \frac{\partial x}{\partial r} \frac{\partial}{\partial x} + \frac{\partial y}{\partial r} \frac{\partial}{\partial y} = \cos \theta \frac{\partial}{\partial x} + \sin \theta \frac{\partial}{\partial y} \\ \frac{\partial}{\partial \theta} &= \frac{\partial x}{\partial \theta} \frac{\partial}{\partial x} + \frac{\partial y}{\partial \theta} \frac{\partial}{\partial y} = -r \sin \theta \frac{\partial}{\partial x} + r \cos \theta \frac{\partial}{\partial y} \end{aligned}$$

We may solve these two equations for the unknowns $\partial/\partial x$ and $\partial/\partial y$. The result is

$$\frac{\partial}{\partial x} = \cos \theta \frac{\partial}{\partial r} - \frac{\sin \theta}{r} \frac{\partial}{\partial \theta} \quad \text{and} \quad \frac{\partial}{\partial y} = \sin \theta \frac{\partial}{\partial r} + \frac{\cos \theta}{r} \frac{\partial}{\partial \theta}.$$

A tedious calculation now reveals that

$$\begin{aligned} \Delta = \frac{\partial^2}{\partial x^2} + \frac{\partial^2}{\partial y^2} &= \left(\cos \theta \frac{\partial}{\partial r} - \frac{\sin \theta}{r} \frac{\partial}{\partial \theta} \right) \left(\cos \theta \frac{\partial}{\partial r} - \frac{\sin \theta}{r} \frac{\partial}{\partial \theta} \right) \\ &\quad + \left(\sin \theta \frac{\partial}{\partial r} + \frac{\cos \theta}{r} \frac{\partial}{\partial \theta} \right) \left(\sin \theta \frac{\partial}{\partial r} + \frac{\cos \theta}{r} \frac{\partial}{\partial \theta} \right) \\ &= \frac{\partial^2}{\partial r^2} + \frac{1}{r} \frac{\partial}{\partial r} + \frac{1}{r^2} \frac{\partial^2}{\partial \theta^2}. \end{aligned}$$

Let us use the so-called separation of variables method to analyze our partial differential equation (11.1). We will seek a solution $w = w(r, \theta) =$

$u(r) \cdot v(\theta)$ of the Laplace equation. Using the polar form, we find that this leads to the equation

$$u''(r) \cdot v(\theta) + \frac{1}{r}u'(r) \cdot v(\theta) + \frac{1}{r^2}u(r) \cdot v''(\theta) = 0.$$

Thus

$$\frac{r^2u''(r) + ru'(r)}{u(r)} = -\frac{v''(\theta)}{v(\theta)}.$$

Since the left-hand side depends only on r , and the right-hand side only on θ , both sides must be constant. Denote the common constant value by λ .

Then we have

$$v''(\theta) + \lambda v(\theta) = 0 \tag{11.2}$$

and

$$r^2u''(r) + ru'(r) - \lambda u(r) = 0. \tag{11.3}$$

In equation (11.2), if we demand that v be continuous and periodic, then we must insist that $\lambda > 0$ and in fact that $\lambda = n^2$ for some nonnegative integer n .¹ For $n = 0$ the only suitable solution of (11.2) is $v \equiv \text{constant}$ and for $n > 0$ the general solution (with $\lambda = n^2$) is

$$v(\theta) = A \cos n\theta + B \sin n\theta,$$

as you can verify directly.

Now we turn to equation (11.3). We set $\lambda = n^2$ and obtain

$$r^2u'' + ru' - n^2u = 0, \tag{11.4}$$

which is Euler's equidimensional equation. The change of variables $r = e^z$ transforms this equation to a linear equation with constant coefficients, and that can in turn be solved with standard techniques. To wit, the equation that we have after the transformation is

$$u'' - n^2u = 0. \tag{11.5}$$

The variable is now z . We guess a solution of the form $u(z) = e^{\alpha z}$. Thus

$$\alpha^2 e^{\alpha z} - n^2 e^{\alpha z} = 0 \tag{11.6}$$

¹More explicitly, $\lambda = 0$ gives a linear function for a solution and $\lambda < 0$ gives an exponential function for a solution.

so that

$$\alpha^2 = \pm n.$$

Hence the solutions of (11.5) are

$$u(z) = e^{nz} \quad \text{and} \quad u(z) = e^{-nz}$$

provided that $n \neq 0$. It follows that the solutions of the original Euler equation (11.4) are

$$u(r) = r^n \quad \text{and} \quad u(r) = r^{-n} \quad \text{for } n \neq 0.$$

In case $n = 0$ the solution is readily seen to be $u = 1$ or $u = \ln r$.

The result is

$$\begin{aligned} u &= A + B \ln r && \text{if } n = 0; \\ u &= Ar^n + Br^{-n} && \text{if } n = 1, 2, 3, \dots \end{aligned}$$

We are most interested in solutions u that are continuous at the origin; so we take $B = 0$ in all cases. The resulting solutions are

$$\begin{aligned} n = 0, & & w &= a_0/2 & (a_0 \text{ a constant}); \\ n = 1, & & w &= r(a_1 \cos \theta + b_1 \sin \theta); \\ n = 2, & & w &= r^2(a_2 \cos 2\theta + b_2 \sin 2\theta); \\ n = 3, & & w &= r^3(a_3 \cos 3\theta + b_3 \sin 3\theta); \\ & & \dots & \end{aligned}$$

Of course any finite sum of solutions of Laplace's equation is also a solution. The same is true for infinite sums. Thus we are led to consider

$$w = w(r, \theta) = \frac{1}{2}a_0 + \sum_{n=1}^{\infty} r^n (a_n \cos n\theta + b_n \sin n\theta).$$

On a formal level, letting $r \rightarrow 1^-$ in this last expression gives

$$\frac{1}{2}a_0 + \sum_{n=1}^{\infty} (a_n \cos n\theta + b_n \sin n\theta).$$

We draw all these ideas together with the following physical rubric. Consider a thin aluminum disc of radius 1, and imagine applying a heat distribution to the boundary of that disc. In polar coordinates, this distribution

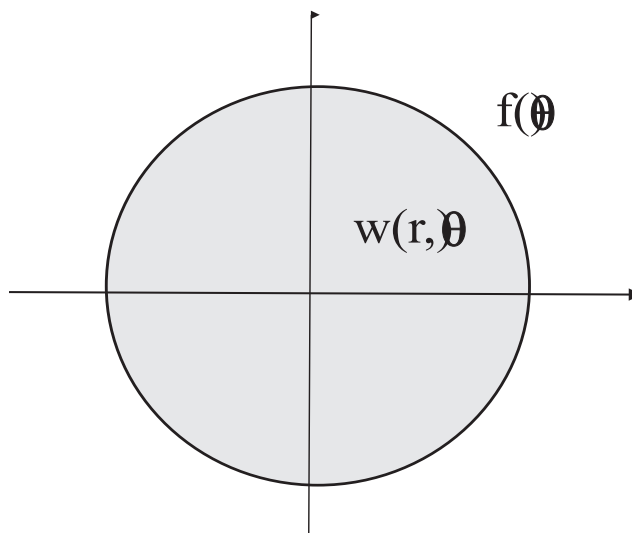


Figure 11.1: Steady state heat distribution on the unit disc.

is specified by a function $f(\theta)$. We seek to understand the steady-state heat distribution on the entire disc. See Figure 11.1. So we seek a function $w(r, \theta)$, continuous on the closure of the disc, which agrees with f on the boundary and which represents the steady-state distribution of heat inside. Some physical analysis shows that such a function w is the solution of the boundary value problem

$$\begin{aligned}\Delta w &= 0, \\ u|_{\partial D} &= f.\end{aligned}$$

According to the calculations we performed prior to this last paragraph, a natural approach to this problem is to expand the given function f in its sine/cosine series:

$$f(\theta) = \frac{1}{2}a_0 + \sum_{n=1}^{\infty} (a_n \cos n\theta + b_n \sin n\theta)$$

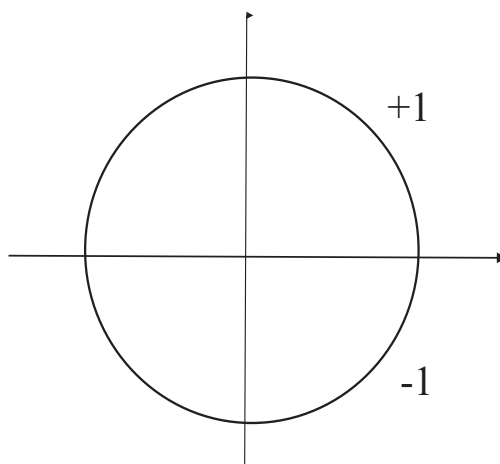


Figure 11.2: Data for the Dirichlet problem.

and then posit that the w we seek is

$$w(r, \theta) = \frac{1}{2}a_0 + \sum_{n=1}^{\infty} r^n (a_n \cos n\theta + b_n \sin n\theta).$$

This process is known as *solving the Dirichlet problem on the disc with boundary data f* .

EXAMPLE 62 Let us follow the paradigm just sketched to solve the Dirichlet problem on the disc with $f(\theta) = 1$ on the top half of the boundary and $f(\theta) = -1$ on the bottom half of the boundary. See Figure 11.2.

It is straightforward to calculate that the Fourier series (sine series) expansion for this f is

$$f(\theta) = \frac{4}{\pi} \left(\sin \theta + \frac{\sin 3\theta}{3} + \frac{\sin 5\theta}{5} + \cdots \right).$$

The solution of the Dirichlet problem is therefore

$$w(r, \theta) = w(re^{i\theta}) = \frac{4}{\pi} \left(r \sin \theta + \frac{r^3 \sin 3\theta}{3} + \frac{r^5 \sin 5\theta}{5} + \cdots \right).$$

□

11.1.3 The Poisson Integral

In the last section we have presented a formal procedure with series for solving the Dirichlet problem. But in fact it is possible to produce a closed formula for this solution. We already saw these ideas, presented in a different way, in Chapter 9. Now we can provide a “Fourier” point of view.

Referring back to our sine/cosine series expansion for f , and the resulting expansion for the solution of the Dirichlet problem, we recall for $n \geq 1$ that

$$a_n = \frac{1}{\pi} \int_{-\pi}^{\pi} f(\phi) \cos n\phi \, d\phi \quad \text{and} \quad b_n = \frac{1}{\pi} \int_{-\pi}^{\pi} f(\phi) \sin n\phi \, d\phi.$$

Thus

$$\begin{aligned} w(r, \theta) = & \frac{1}{2}a_0 + \sum_{n=1}^{\infty} r^n \left(\frac{1}{\pi} \int_{-\pi}^{\pi} f(\phi) \cos n\phi \, d\phi \cos n\theta \right. \\ & \left. + \frac{1}{\pi} \int_{-\pi}^{\pi} f(\phi) \sin n\phi \, d\phi \sin n\theta \right). \end{aligned}$$

This, in turn, equals

$$\begin{aligned} & \frac{1}{2}a_0 + \frac{1}{\pi} \sum_{n=1}^{\infty} r^n \int_{-\pi}^{\pi} f(\phi) \left[\cos n\phi \cos n\theta + \sin n\phi \sin n\theta \right] d\phi \\ & = \frac{1}{2}a_0 + \frac{1}{\pi} \sum_{n=1}^{\infty} r^n \int_{-\pi}^{\pi} f(\phi) \left[\cos n(\theta - \phi) \right] d\phi. \end{aligned}$$

Note that what we have done here is simply to exploit our explicit formulas for a_n and b_n .

We finally simplify our expression to

$$w(r, \theta) = \frac{1}{\pi} \int_{-\pi}^{\pi} f(\phi) \left[\frac{1}{2} + \sum_{n=1}^{\infty} r^n \cos n(\theta - \phi) \right] d\phi.$$

It behooves us, therefore, to calculate the sum inside the brackets. For simplicity, we let $\alpha = \theta - \phi$ and then we let

$$z = re^{i\alpha} = r(\cos \alpha + i \sin \alpha).$$

Likewise

$$z^n = r^n e^{in\alpha} = r^n(\cos n\alpha + i \sin n\alpha).$$

Let $\operatorname{Re} z$ denote the real part of the complex number z . Then

$$\begin{aligned}
 \frac{1}{2} + \sum_{n=1}^{\infty} r^n \cos n\alpha &= \operatorname{Re} \left[\frac{1}{2} + \sum_{n=1}^{\infty} z^n \right] \\
 &= \operatorname{Re} \left[-\frac{1}{2} + \sum_{n=0}^{\infty} z^n \right] \\
 &= \operatorname{Re} \left[-\frac{1}{2} + \frac{1}{1-z} \right] \\
 &= \operatorname{Re} \left[\frac{1+z}{2(1-z)} \right] \\
 &= \operatorname{Re} \left[\frac{(1+z)(1-\bar{z})}{2|1-z|^2} \right] \\
 &= \frac{1-|z|^2}{2|1-z|^2} \\
 &= \frac{1-r^2}{2(1-2r\cos\alpha+r^2)}.
 \end{aligned}$$

Putting the result of this calculation into our original formula for w we finally obtain the Poisson integral formula:

$$w(r, \theta) = \frac{1}{2\pi} \int_{-\pi}^{\pi} \frac{1-r^2}{1-2r\cos\alpha+r^2} f(\phi) d\phi.$$

Observe what this formula does for us: It expresses the solution of the Dirichlet problem with boundary data f as an explicit integral of a universal expression (called a *kernel*) against that data function f .

There is a great deal of information about w and its relation to f contained in this formula. As just one simple instance, we note that when r is set equal to 0 then we obtain

$$w(0, \theta) = \frac{1}{2\pi} \int_{-\pi}^{\pi} f(\phi) d\phi.$$

This says that the value of the steady-state heat distribution at the origin is just the average value of f around the circular boundary. We have just used the Poisson integral formula, derived using partial differential equations and Fourier analysis, to rediscover the mean value property of harmonic functions.

EXAMPLE 63 Let us use the Poisson integral formula to solve the Dirichlet problem for the boundary data $f(\phi) = e^{2i\phi}$. We know that the solution is given by

$$\begin{aligned} w(r, \theta) &= \frac{1}{2\pi} \int_{-\pi}^{\pi} \frac{1-r^2}{1-2r\cos\alpha+r^2} f(\phi) d\phi \\ &= \frac{1}{2\pi} \int_{-\pi}^{\pi} \frac{1-r^2}{1-2r\cos\alpha+r^2} e^{2i\phi} d\phi. \end{aligned}$$

With some effort, one can evaluate this integral to find that

$$w(r, \theta) = r^2 e^{2i\theta}.$$

In complex notation, w is the function $z \mapsto z^2$. □

11.1.4 The Wave Equation

We consider the wave equation

$$a^2 y_{xx} = y_{tt} \tag{11.7}$$

on the interval $[0, \pi]$ with the boundary conditions

$$y(0, t) = 0$$

and

$$y(\pi, t) = 0.$$

This equation, with boundary conditions, is a mathematical model for a vibrating string with the ends (at $x = 0$ and $x = \pi$) pinned down. The function $y(x, t)$ describes the ordinate of the point x on the string at time t . See Figure 11.3.

Physical considerations dictate that we also impose the initial velocity and displacement of the string. Thus

$$\left. \frac{\partial y}{\partial t} \right|_{t=0} = 0 \tag{11.8}$$

(indicating that the initial velocity of the string is 0) and

$$y(x, 0) = f(x) \tag{11.9}$$

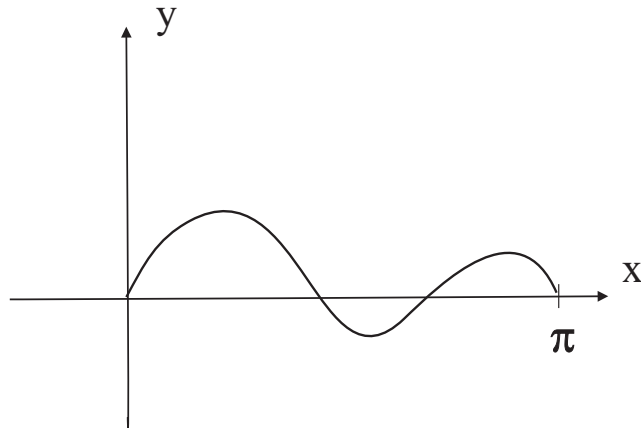


Figure 11.3: The vibrating string.

(indicating that the initial configuration of the string is the graph of the function f).

We solve the wave equation using a version of separation of variables. For convenience, we assume that the constant $a = 1$. We guess a solution of the form $u(x, t) = u(x) \cdot v(t)$. Putting this guess into the differential equation

$$u_{xx} = u_{tt}$$

gives

$$u''(x)v(t) = u(x)v''(t).$$

We may obviously separate variables, in the sense that we may write

$$\frac{u''(x)}{u(x)} = \frac{v''(t)}{v(t)}.$$

The left-hand side depends only on x while the right-hand side depends only on t . The only way this can be true is if

$$\frac{u''(x)}{u(x)} = \lambda = \frac{v''(t)}{v(t)}$$

for some constant λ . But this gives rise to two second-order linear, ordinary differential equations that we can solve explicitly:

$$u''(x) = \lambda \cdot u(x) \tag{11.10}$$

$$v'' = \lambda \cdot v. \quad (11.11)$$

Observe that this is the *same* constant λ in both of these equations. Now, as we have already discussed, we want the initial configuration of the string to pass through the points $(0, 0)$ and $(\pi, 0)$. We can achieve these conditions by solving (11.10) with $u(0) = 0$ and $u(\pi) = 0$.

This problem (with these particular boundary conditions) has a nontrivial solution if and only if $\lambda = n^2$ for some positive integer n , and the corresponding function is

$$u_n(x) = \sin nx.$$

For this same λ , the general solution of (11.11) is

$$v(t) = A \sin nt + B \cos nt.$$

If we impose the requirement that $v'(0) = 0$, so that (11.8) is satisfied, then $A = 0$ and we find the solution

$$v(t) = B \cos nt.$$

This means that the solution we have found of our differential equation with the given boundary and initial conditions is

$$y_n(x, t) = \sin nx \cos nt. \quad (11.12)$$

And in fact any finite sum with constant coefficients (or *linear combination*) of these solutions will also be a solution:

$$y = \alpha_1 \sin x \cos t + \alpha_2 \sin 2x \cos 2t + \cdots + \alpha_k \sin kx \cos kt.$$

In physics, this is called the “principle of superposition.”

Ignoring the rather delicate issue of convergence, we may claim that any *infinite* linear combination of the solutions (11.12) will also be a solution:

$$y = \sum_{j=1}^{\infty} b_j \sin jx \cos jt. \quad (11.13)$$

Now we must examine the final condition (11.9). The mandate $y(x, 0) = f(x)$ translates to

$$\sum_{j=1}^{\infty} b_j \sin jx = y(x, 0) = f(x) \quad (11.14)$$

or

$$\sum_{j=1}^{\infty} b_j u_j(x) = y(x, 0) = f(x), \quad (11.15)$$

where $u_j(x) = \sin jx$. Thus we demand that f have a valid Fourier series expansion. We know from our studies earlier in this chapter that such an expansion is valid for a rather broad class of functions f . Thus the wave equation is in principle solvable in considerable generality.

Remark: An important point about Fourier expansions needs to be developed at this point. When we are doing Fourier analysis on the interval $[0, 2\pi)$, we need all the functions $\cos jx$ and all the functions $\sin jx$. If any of these were omitted, we would not be able to expand “any” integrable function in a Fourier series. But on the interval $[0, \pi)$ things are different. Let f be a given function on $[0, \pi)$. Now define

$$\tilde{f}(x) = \begin{cases} f(x) & \text{if } 0 \leq x < \pi \\ -f(-x) & \text{if } -\pi < x < 0. \end{cases}$$

We call \tilde{f} the “odd extension” of f to the full interval $[-\pi, \pi)$. Now look what happens when we go to calculate the a_j for \tilde{f} :

$$a_j = \frac{1}{\pi} \int_{-\pi}^{\pi} \tilde{f}(x) \cos jt \, dt.$$

The integrand, being the product of an odd function and an even function, is odd. Thus it integrates to 0! Thus the Fourier series for \tilde{f} does not have any cosine terms. It only has sine terms.

The upshot of the discussion in the last paragraph is that when we are working on the interval $[0, \pi)$, as in our study of the wave equation, we can expand *any* data function f in terms of sine functions only. And that is what the situation calls for.

Exercise for the Reader: Emulate the argument in the preceding remark to see that one can expand a function on $[0, \pi)$ in terms of cosine functions only.

We know that our eigenfunctions u_j satisfy

$$u_m'' = -m^2 u_m \quad \text{and} \quad u_n'' = -n^2 u_n.$$

Multiply the first equation by u_n and the second by u_m and subtract. The result is

$$u_n u_m'' - u_m u_n'' = (n^2 - m^2) u_n u_m$$

or

$$[u_n u_m' - u_m u_n']' = (n^2 - m^2) u_n u_m.$$

We integrate both sides of this last equation from 0 to π and use the fact that $u_j(0) = u_j(\pi) = 0$ for every j . The result is

$$0 = [u_n u_m' - u_m u_n'] \Big|_0^\pi = (n^2 - m^2) \int_0^\pi u_m(x) u_n(x) dx.$$

Thus

$$\int_0^\pi \sin mx \sin nx dx = 0 \quad \text{for } n \neq m \quad (11.16)$$

or

$$\int_0^\pi u_m(x) u_n(x) dx = 0 \quad \text{for } n \neq m. \quad (11.17)$$

Of course this is a standard fact from calculus. It played an important (tacit) role in Section 11.2, when we first learned about Fourier series. It is commonly referred to as an “orthogonality condition,” and is fundamental to the Fourier theory and the more general Sturm-Liouville theory. We now see how the condition arises naturally from the differential equation.

In view of the orthogonality condition (11.17), it is natural to integrate both sides of (11.15) against $u_k(x)$. The result is

$$\begin{aligned} \int_0^\pi f(x) \cdot u_k(x) dx &= \int_0^\pi \left[\sum_{j=0}^{\infty} b_j u_j(x) \right] \cdot u_k(x) dx \\ &= \sum_{j=0}^{\infty} b_j \int_0^\pi u_j(x) u_k(x) dx \\ &= b_k \int_0^\pi u_k(x) u_k(x) dx \\ &= \frac{\pi}{2} b_k. \end{aligned}$$

The b_k are the Fourier coefficients that we studied in Section 11.1.1.

Certainly Fourier analysis has been one of the driving forces in the development of modern analysis. Questions of sets of convergence for Fourier series led to Cantor's set theory. Other convergence questions led to Dirichlet's original definition of convergent series. Riemann's theory of the integral first occurs in his classic paper on Fourier series. In turn, the tools of analysis shed much light on the fundamental questions of Fourier theory.

In more modern times, Fourier analysis was an impetus to the development of functional analysis, pseudodifferential operators, and many of the other key ideas in the subject. It continues to enjoy a symbiotic relationship with many of the newest and most incisive ideas in mathematical analysis.

One of the modern vectors in harmonic analysis is the development of wavelet theory. This is a "designer" version of harmonic analysis that allows the user to customize the building blocks. That is to say: classically, harmonic analysis taught us to build up functions from sines and cosines; wavelet theory allows us to build up functions from units that are tailored to the problem at hand. This has proved to be a powerful tool for signal processing, signal compression, and many other contexts in which a fine and rapidly converging analysis is desirable.

Exercises

1. Find the Fourier series of the function

$$f(x) = \begin{cases} \pi & \text{if } -\pi \leq x \leq \frac{\pi}{2} \\ 0 & \text{if } \frac{\pi}{2} < x \leq \pi. \end{cases}$$

2. Find the Fourier series for the function

$$f(x) = \begin{cases} 0 & \text{if } -\pi \leq x < 0 \\ 1 & \text{if } 0 \leq x \leq \frac{\pi}{2} \\ 0 & \text{if } \frac{\pi}{2} < x \leq \pi. \end{cases}$$

3. Find the Fourier series of the function

$$f(x) = \begin{cases} 0 & \text{if } -\pi \leq x < 0 \\ \sin x & \text{if } 0 \leq x \leq \pi. \end{cases}$$

4. Solve Exercise 3 with $\sin x$ replaced by $\cos x$.
5. Find the Fourier series for each of these functions. Pay special attention to the reasoning used to establish your conclusions; consider alternative lines of thought.

(a) $f(x) = \pi$, $-\pi \leq x \leq \pi$

(b) $f(x) = \sin x$, $-\pi \leq x \leq \pi$

(c) $f(x) = \cos x$, $-\pi \leq x \leq \pi$

(d) $f(x) = \pi + \sin x + \cos x$, $-\pi \leq x \leq \pi$

6. Find the Fourier series for the function given by

(a)

$$f(x) = \begin{cases} -a & \text{if } -\pi \leq x < 0 \\ a & \text{if } 0 \leq x \leq \pi \end{cases}$$

for a a positive real number.

(b)

$$f(x) = \begin{cases} -1 & \text{if } -\pi \leq x < 0 \\ 1 & \text{if } 0 \leq x \leq \pi \end{cases}$$

(c)

$$f(x) = \begin{cases} -\frac{\pi}{4} & \text{if } -\pi \leq x < 0 \\ \frac{\pi}{4} & \text{if } 0 \leq x \leq \pi \end{cases}$$

(d)

$$f(x) = \begin{cases} -1 & \text{if } -\pi \leq x < 0 \\ 2 & \text{if } 0 \leq x \leq \pi \end{cases}$$

(e)

$$f(x) = \begin{cases} 1 & \text{if } -\pi \leq x < 0 \\ 2 & \text{if } 0 \leq x \leq \pi \end{cases}$$

7. Find the Fourier series for the periodic function defined by

$$f(x) = \begin{cases} -\pi & \text{if } -\pi \leq x < 0 \\ x & \text{if } 0 \leq x < \pi \end{cases}$$

What can you say about the behavior of this series at the endpoints $-\pi, \pi$ of the interval?

8. (a) Find the Fourier series for the periodic function defined by $f(x) = e^x$, $-\pi \leq x \leq \pi$. [**Hint:** Recall that $\sinh x = (e^x - e^{-x})/2$.]
 (b) Sketch the graph of the sum of this series on the interval $-5\pi \leq x \leq 5\pi$.
 (c) Use the series in (a) to establish the sums

$$\sum_{n=1}^{\infty} \frac{1}{n^2 + 1} = \frac{1}{2} \left(\frac{\pi}{\tanh \pi} - 1 \right)$$

and

$$\sum_{n=1}^{\infty} \frac{(-1)^n}{n^2 + 1} = \frac{1}{2} \left(\frac{\pi}{\sinh \pi} - 1 \right).$$

9. (a) Show that the Fourier series for the periodic function

$$f(x) = \begin{cases} 0 & \text{if } -\pi \leq x < 0 \\ x^2 & \text{if } 0 \leq x < \pi \end{cases}$$

is

$$\begin{aligned} f(x) &= \frac{\pi^2}{6} + 2 \sum_{n=1}^{\infty} (-1)^n \frac{\cos nx}{n^2} \\ &\quad + \pi \sum_{n=1}^{\infty} (-1)^{n+1} \frac{\sin nx}{n} - \frac{4}{\pi} \sum_{n=1}^{\infty} \frac{\sin(2n-1)x}{(2n-1)^3}. \end{aligned}$$

- (b) Use the series in part (a) with $x = 0$ and $x = \pi$ to obtain the two sums

$$1 - \frac{1}{2^2} + \frac{1}{3^2} - \frac{1}{4^2} + \cdots = \frac{\pi^2}{12}$$

and

$$1 + \frac{1}{2^2} + \frac{1}{3^2} + \frac{1}{4^2} + \cdots = \frac{\pi^2}{6}.$$

- (c) Derive the second sum in (b) from the first. [**Hint:** Add $2 \sum_n (1/[2n])^2$ to both sides.]

10. Find the Fourier series for the 2π -periodic function defined on its fundamental period $[-\pi, \pi]$ by

$$f(x) = \begin{cases} x + \frac{\pi}{2} & \text{if } -\pi \leq x < 0 \\ -x + \frac{\pi}{2} & \text{if } 0 \leq x \leq \pi \end{cases}$$

- (a) by computing the Fourier coefficients directly;
 (b) using the formula

$$|x| = \frac{\pi}{2} - \frac{4}{\pi} \left(\cos x + \frac{\cos 3x}{3^2} + \frac{\cos 5x}{5^2} + \cdots \right).$$

Sketch the graph of the sum of this series (a triangular wave) on the interval $-5\pi \leq x \leq 5\pi$.

11. Find the Fourier series for the function of period 2π defined by $f(x) = \cos x/2$, $-\pi \leq x \leq \pi$.
 12. If $w = F(x, y) = \mathcal{F}(r, \theta)$, with $x = r \cos \theta$ and $y = r \sin \theta$, then show that

$$\begin{aligned} \frac{\partial^2 w}{\partial x^2} + \frac{\partial^2 w}{\partial y^2} &= \frac{1}{r} \left\{ \frac{\partial}{\partial r} \left(r \frac{\partial w}{\partial r} \right) + \frac{1}{r} \frac{\partial^2 w}{\partial \theta^2} \right\} \\ &= \frac{\partial^2 w}{\partial r^2} + \frac{1}{r} \frac{\partial w}{\partial r} + \frac{1}{r^2} \frac{\partial^2 w}{\partial \theta^2}. \end{aligned}$$

[**Hint:** We can calculate that

$$\frac{\partial w}{\partial r} = \frac{\partial w}{\partial x} \cos \theta + \frac{\partial w}{\partial y} \sin \theta \quad \text{and} \quad \frac{\partial w}{\partial \theta} = \frac{\partial w}{\partial x} (-r \sin \theta) + \frac{\partial w}{\partial y} (r \cos \theta).]$$

Similarly, compute $\frac{\partial}{\partial r} \left(r \frac{\partial w}{\partial r} \right)$ and $\frac{\partial^2 w}{\partial \theta^2}$.

13. Prove the trigonometric identities

$$\sin^3 x = \frac{3}{4} \sin x - \frac{1}{4} \sin 3x \quad \text{and} \quad \cos^3 x = \frac{3}{4} \cos x + \frac{1}{4} \cos 3x$$

and show briefly, without calculation, that these are the Fourier series expansions of the functions $\sin^3 x$ and $\cos^3 x$.

14. Solve the Dirichlet problem for the unit disc when the boundary function $f(\theta)$ is defined by
 (a) $f(\theta) = \cos \theta/2$, $-\pi \leq \theta \leq \pi$
 (b) $f(\theta) = \theta$, $-\pi < \theta < \pi$

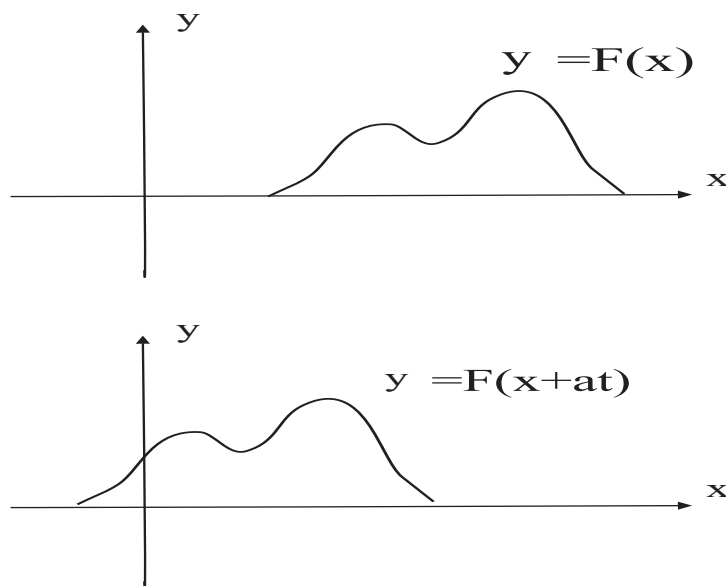


Figure 11.4: A moving wave.

$$(c) f(\theta) = \begin{cases} 0 & \text{if } -\pi \leq \theta < 0 \\ \sin \theta & \text{if } 0 \leq \theta \leq \pi \end{cases}$$

$$(d) f(\theta) = \begin{cases} 0 & \text{if } -\pi \leq \theta < 0 \\ 1 & \text{if } 0 \leq \theta \leq \pi \end{cases}$$

$$(e) f(\theta) = \theta^2/4, \quad -\pi \leq \theta \leq \pi$$

15. Show that

$$\frac{L}{2} - x = \frac{L}{\pi} \sum_{n=1}^{\infty} \frac{1}{n} \sin \frac{2n\pi x}{L}, \quad -L < x < L.$$

16. If $y = F(x)$ is an arbitrary function, then $y = F(x + at)$ represents a wave of fixed shape that moves to the left along the x -axis with velocity a (Figure 11.4).

Similarly, if $y = G(x)$ is another arbitrary function, then $y = G(x - at)$ is a wave moving to the right, and the most general one-dimensional

wave with velocity a is

$$y(x, t) = F(x + at) + G(x - at). \quad (*)$$

- (a) Show that (*) satisfies the wave equation.
- (b) It is easy to see that the constant a in the wave equation has the dimensions of velocity. Also, it is intuitively clear that if a stretched string is disturbed, then the waves will move in both directions away from the source of the disturbance. These considerations suggest introducing the new variables $\alpha = x + at$, $\beta = x - at$. Show that with these independent variables, equation (6) becomes

$$\frac{\partial^2 y}{\partial \alpha \partial \beta} = 0.$$

From this derive (*) by integration. Formula (*) is called *d'Alembert's solution* of the wave equation. It was also obtained, slightly later and independently, by Euler.

17. Let w be a harmonic function in a planar region, and let C be any circle entirely contained (along with its interior) in this region. Prove that the value of w at the center of C is the average of its values on the circumference.
18. Consider an infinite string stretched taut on the x -axis from $-\infty$ to $+\infty$. Let the string be drawn aside into a curve $y = f(x)$ and released, and assume that its subsequent motion is described by the wave equation.
- (a) Use (*) in Exercise 16 to show that the string's displacement is given by *d'Alembert's formula*

$$y(x, t) = \frac{1}{2}[f(x + at) + f(x - at)]. \quad (**)$$

[**Hint:** Remember the initial conditions (7) and (8).]

- (b) Assume further that the string remains motionless at the points $x = 0$ and $x = \pi$ (such points are called *nodes*), so that $y(0, t) = y(\pi, t) = 0$, and use (**) to show that f is an odd function that is periodic with period 2π (that is, $f(-x) = f(x)$ and $f(x + 2\pi) = f(x)$).

(c) Show that since f is odd and periodic with period 2π then f necessarily vanishes at 0 and π .

19. Show that the Dirichlet problem for the disc $\{(x, y) : x^2 + y^2 \leq R^2\}$, where $f(\theta)$ is the boundary function, has the solution

$$w(r, \theta) = \frac{1}{2}a_0 + \sum_{n=1}^{\infty} \left(\frac{r}{R}\right)^n (a_n \cos n\theta + b_n \sin n\theta)$$

where a_n and b_n are the Fourier coefficients of f . Show also that the Poisson integral formula for this more general disc setting is

$$w(r, \theta) = \frac{1}{2\pi} \int_{-\pi}^{\pi} \frac{R^2 - r^2}{R^2 - 2Rr \cos(\theta - \phi) + r^2} f(\phi) d\phi.$$

20. Solve the vibrating string problem in the text if the initial shape $y(x, 0) = f(x)$ is specified by the given function. In each case, sketch the initial shape of the string on a set of axes.

(a)

$$f(x) = \begin{cases} 2cx/\pi & \text{if } 0 \leq x \leq \pi/2 \\ 2c(\pi - x)/\pi & \text{if } \pi/2 \leq x \leq \pi \end{cases}$$

(b)

$$f(x) = \frac{1}{\pi}x(\pi - x)$$

(c)

$$f(x) = \begin{cases} x & \text{if } 0 \leq x \leq \pi/4 \\ \pi/4 & \text{if } \pi/4 < x < 3\pi/4 \\ \pi - x & \text{if } 3\pi/4 \leq x \leq \pi \end{cases}$$

21. It would be quite difficult to calculate the relevant integrals for this problem by hand. Instead use **MatLab** to calculate the Poisson integral of the given function on $[-\pi, \pi]$.

(a) $f(\theta) = \ln^2 \theta$

(b) $f(\theta) = \theta^3 \cdot \cos \theta$

(c) $f(\theta) = e^\theta \cdot \sin \theta$

(d) $f(\theta) = e^\theta \cdot \ln \theta$

22. Solve the vibrating string problem in the text if the initial shape $y(x, 0) = f(x)$ is that of a single arch of the sine curve $f(x) = c \sin x$. Show that the moving string always has the same general shape, regardless of the value of c . Do the same for functions of the form $f(x) = c \sin nx$. Show in particular that there are $n - 1$ points between $x = 0$ and $x = \pi$ at which the string remains motionless; these points are called *nodes*, and these solutions are called *standing waves*. Draw sketches to illustrate the movement of the standing waves.
23. If f, g are integrable functions on \mathbb{R} then define their *convolution* to be

$$h(x) = f * g(x) = \int_{\mathbb{R}} f(x - t)g(t) dt.$$

Prove that

$$\widehat{h}(\xi) = \widehat{f}(\xi) \cdot \widehat{g}(\xi).$$

24. The problem of the *struck string* is that of solving the wave equation with the boundary conditions

$$y(0, t) = 0 \quad , \quad y(\pi, t) = 0$$

and the initial conditions

$$\left. \frac{\partial y}{\partial t} \right|_{t=0} = g(x) \quad \text{and} \quad y(x, 0) = 0.$$

[These initial conditions reflect the fact that the string is initially in the equilibrium position, and has an initial velocity $g(x)$ at the point x as a result of being struck.] By separating variables and proceeding formally, obtain the solution

$$y(x, t) = \sum_{n=1}^{\infty} c_n \sin nx \sin nat,$$

where

$$c_n = \frac{2}{\pi na} \int_0^{\pi} g(x) \sin nx dx.$$

25. Write a MatLab routine that will calculate the j^{th} Fourier coefficient of any given function on the interval $[0, 2\pi)$.

26. Solve the boundary value problem

$$\begin{aligned} a^2 \frac{\partial^2 w}{\partial x^2} &= \frac{\partial w}{\partial t} \\ w(x, 0) &= f(x) \\ w(0, t) &= 0 \\ w(\pi, t) &= 0 \end{aligned}$$

if the last three conditions—the boundary conditions—are changed to

$$\begin{aligned} w(x, 0) &= f(x) \\ w(0, t) &= w_1 \\ w(\pi, t) &= w_2. \end{aligned}$$

[**Hint:** Write $w(x, t) = W(x, t) + g(x)$.]

27. Write a **MatLab** routine that will calculate the N^{th} partial sum of the Fourier series of any given function on the interval $[0, 2\pi)$. [**Hint:** You will have to think about how to format the answer to this question.]
28. Suppose that the lateral surface of the thin rod that we analyzed in the text is not insulated, but in fact radiates heat into the surrounding air. If Newton's law of cooling (that a body cools at a rate proportional to the difference of its temperature with the temperature of the surrounding air) is assumed to apply, then show that the 1-dimensional heat equation becomes

$$a^2 \frac{\partial^2 w}{\partial x^2} = \frac{\partial w}{\partial t} + c(w - w_0)$$

where c is a positive constant and w_0 is the temperature of the surrounding air.

29. The functions $\sin^2 x$ and $\cos^2 x$ are both even. Show, without using any calculations, that the identities

$$\sin^2 x = \frac{1}{2}(1 - \cos 2x) = \frac{1}{2} - \frac{1}{2} \cos 2x$$

and

$$\cos^2 x = \frac{1}{2}(1 + \cos 2x) = \frac{1}{2} + \frac{1}{2} \cos 2x$$

are actually the Fourier series expansions of these functions.

30. In Exercise 22, find $w(x, t)$ if the ends of the rod are kept at 0°C , $w_0 = 0^\circ\text{C}$, and the initial temperature distribution on the rod is $f(x)$.
31. Derive the three-dimensional heat equation

$$a^2 \left(\frac{\partial^2 w}{\partial x^2} + \frac{\partial^2 w}{\partial y^2} + \frac{\partial^2 w}{\partial z^2} \right) = \frac{\partial w}{\partial t}$$

by adapting the reasoning in the text to the case of a small box with edges Δx , Δy , Δz contained in a region R in x - y - z space where the temperature function $w(x, y, z, t)$ is sought. [**Hint:** Consider the flow of heat through two opposite faces of the box, first perpendicular to the x -axis, then perpendicular to the y -axis, and finally perpendicular to the z -axis.]

32. In the solution of the heat equation, suppose that the ends of the rod are insulated instead of being kept fixed at 0°C . What are the new boundary conditions? Find the temperature $w(x, t)$ in this case by using just common sense.

Chapter 12

Computer Packages for Studying Complex Variables

12.0 Introductory Remarks

In the past two decades or so, there has been a wide proliferation of high speed digital computing equipment. Concomitant with that growth has been the development of ever more sophisticated analytic tools for doing mathematics. Gone are the days of using the computer simply as a “number cruncher.” Now there are sophisticated computer algebra software and two- and three-dimensional graphing software. In the present chapter we shall give brief descriptions of the major packages that are useful in doing complex analysis.

We note that the producers of computer algebra systems in general have been slow to respond to the need for complex-analytic computing capabilities. The engineering-oriented package `MatLab` has been a leader in providing ease-of-use for those wishing to do complex analysis. It is only the latest releases of `Mathematica` and `Maple` that have serious power in complex arithmetic. The specialized software `f(z)` does *only* complex analysis, but its capabilities are very particular. It has many graphing features, but it has limited ability to do calculations.

12.1 The Software Packages

12.1.1 The Software $f(z)$ [®]

The software $f(z)$ by Lascaux Software, available for both the PC and Macintosh platforms, was one of the first to accept complex-analytic input and to be able to produce graphs of holomorphic functions. The most recent release for the Windows platform, available on CD-ROM, is particularly attractive.

The primary purpose of $f(z)$ is to graph holomorphic functions. Of course the graph actually lives in $\mathbb{C} \times \mathbb{C}$, which is four-dimensional Euclidean space. We may only view a rendition of the graph on a two-dimensional screen. The software $f(z)$ offers the user the option of viewing the graph in a great variety of configurations. Among these are

- (12.1) As a collection of images (in the plane) of circular level curves.
- (12.2) As a collection of images (in the plane) of rectilinear level curves.
- (12.3) Either (12.1) or (12.2) with the images lying in the Riemann sphere.
- (12.4) As a graph in three dimensions (where attention is restricted to either the real part or the imaginary part of the image).
- (12.5) As a graph in four-dimensional space.

Of course (12.5) can only be suggested through a variety of graphical tricks. In particular, animations are used in a compelling manner to suggest how various three-dimensional cross-sections fit together to compose the four-dimensional “graph.” The commands in $f(z)$ enable easy redefinition of the function, zooming, repositioning, and rotation.

Functions may be defined by direct entry of the function name or by composition or by iteration. It is possible to draw Julia sets, fractals, Mandelbrot sets, and the various states generated by the complex Newton’s method.

Beautiful printouts are straightforward to produce; resolution, colors, and other attributes may be adjusted to suit. The software is transparent to use; resort to the documentation is rarely necessary.

Although the strength of this software has traditionally been graphics, the newest Windows release also features numerical computation of complex line integrals. One can calculate winding numbers and verify the Cauchy integral formula and theorem in particular instances.

Figures 12.1 through 12.12 exhibit some representative $f(z)$ output. They depict the following:

[**The function $f(z) = \exp(z)$**] Figure 12.1 shows the image in the plane of circular level curves under $\exp(z) = e^z$; Figure 12.2 shows the image in the Riemann sphere of circular level curves under e^z ; Figure 12.3 shows the graph in 3-space of circular level curves under e^z .

[**The function $f(z) = z^2$**] Figure 12.4 shows the image in the plane of circular level curves under z^2 ; Figure 12.5 shows the image in the Riemann sphere of circular level curves under z^2 ; Figure 12.6 shows the graph in four-space of circular level curves acted on by z^2 .

[**Image of a rectangular grid under $\exp(z)$**] Figure 12.7 shows the image in the plane of a rectangular grid under $\exp(z) = e^z$; Figure 12.8 shows the image in the Riemann sphere of a rectangular grid under z^2 ; Figure 12.9 the graph in four-space of a rectangular grid under $z^3 - 3z^2 + z - 2$.

[**The image of a rectangular grid under $f(z) = \log z$**] Figure 12.10 shows the image in the plane of a rectangular grid under $\log z$; Figure 12.11 shows the image in the Riemann sphere of a rectangular grid under $\log z$; Figure 12.12 shows the graph in four-space of a rectangular grid under $\log z$.

12.1.2 Mathematica[®]

Mathematica by Wolfram Research is a powerful all-around mathematics utility. It can perform computer algebra operations and numerical calculations, and has stunning graphing utilities. Version 5 is particularly well-equipped with complex analysis capabilities. See [WOL] for details of the Mathematica syntax.

A complex number is denoted $a + bI$. Mathematica can convert such a complex number to polar form, expressed either with trigonometric functions or in exponential notation. All complex arithmetic operations are performed with straightforward commands. For example, the input

$$(4 + 3I)/(2 - I)$$

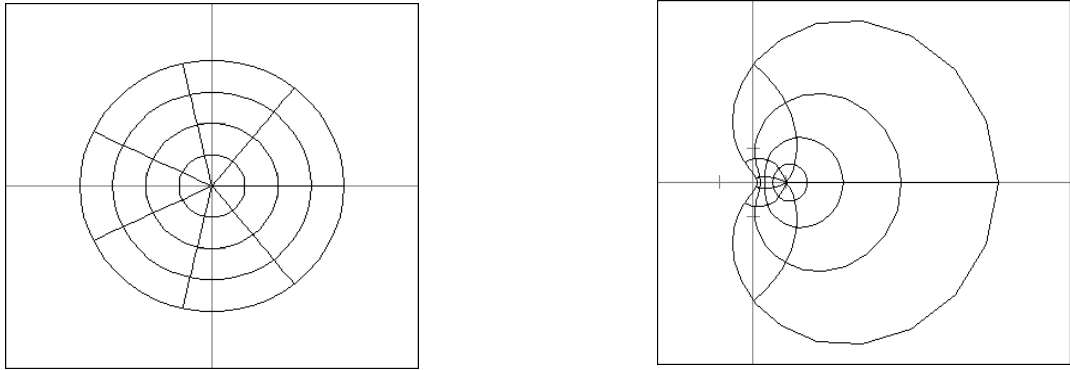


Figure 12.1: The image in the plane of circular level curves under e^z .

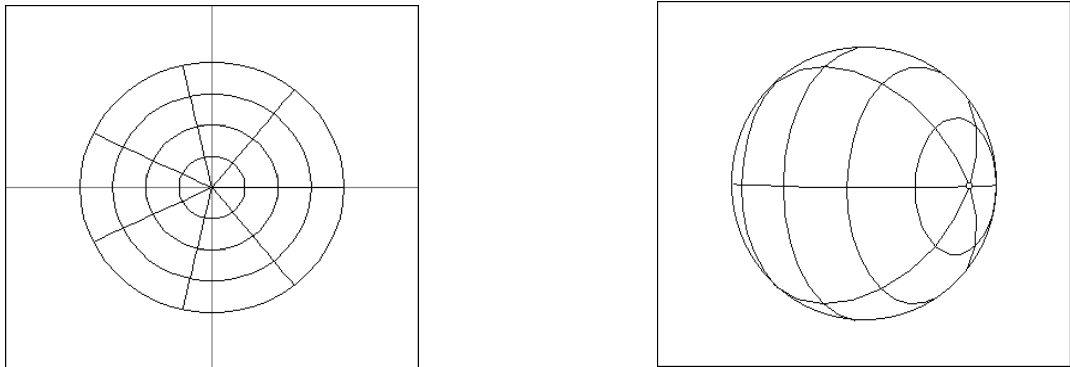


Figure 12.2: The image in the Riemann sphere of circular level curves under e^z .

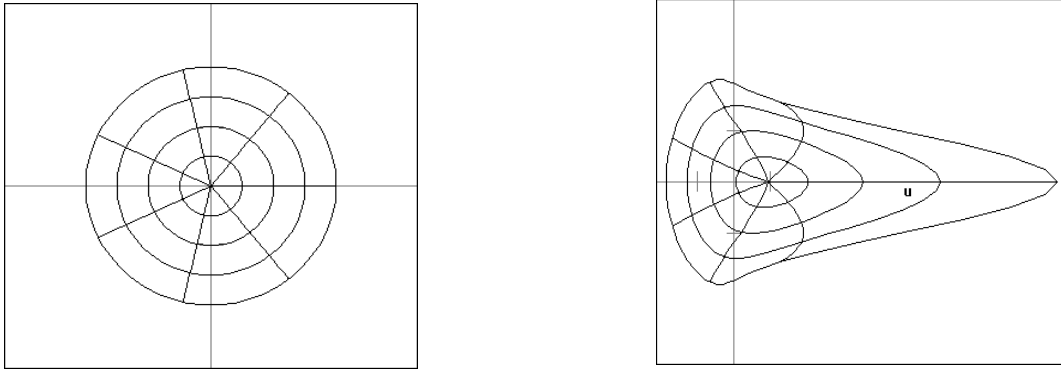


Figure 12.3: The graph in three-space of circular level curves acted on by e^z .

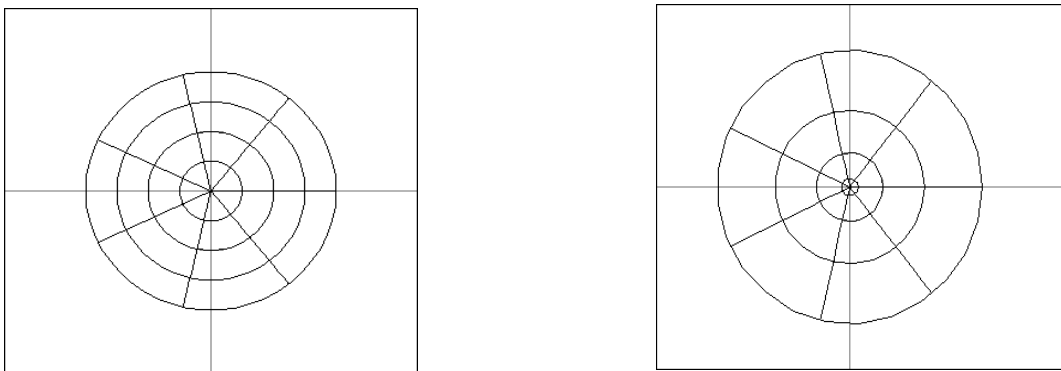


Figure 12.4: The image in the plane of circular level curves under z^2 .

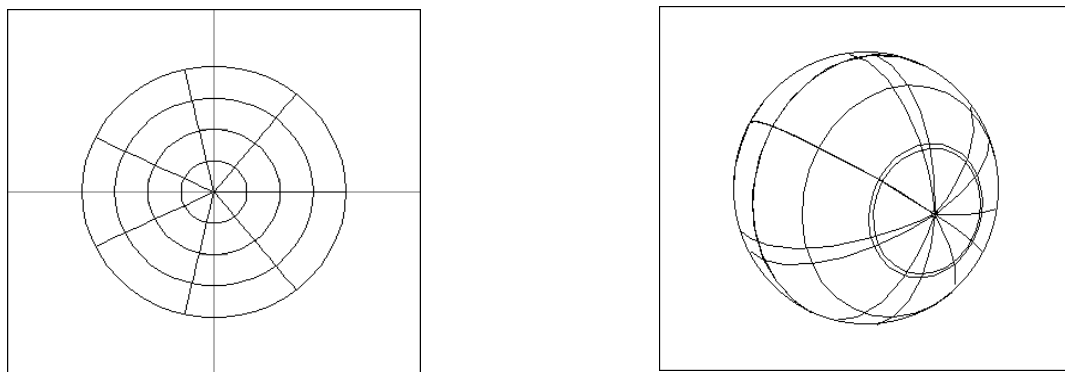


Figure 12.5: The image in the Riemann sphere of circular level curves under z^2 .

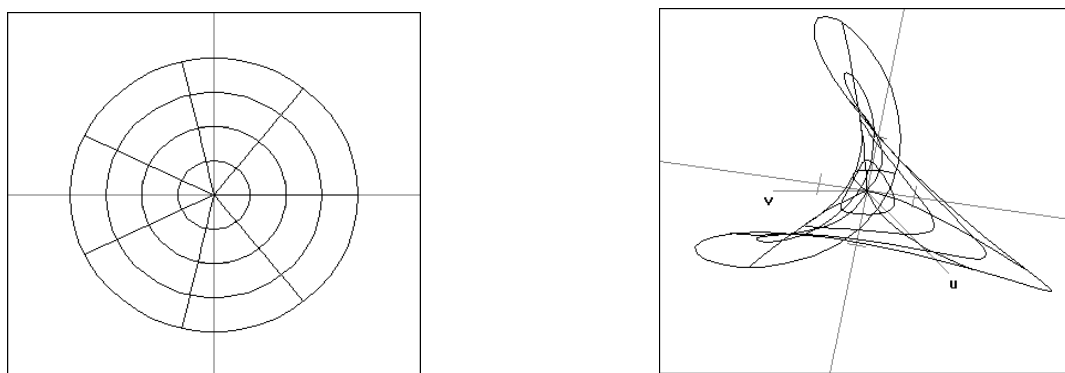


Figure 12.6: The graph in four-space of circular level curves acted on by z^2 .

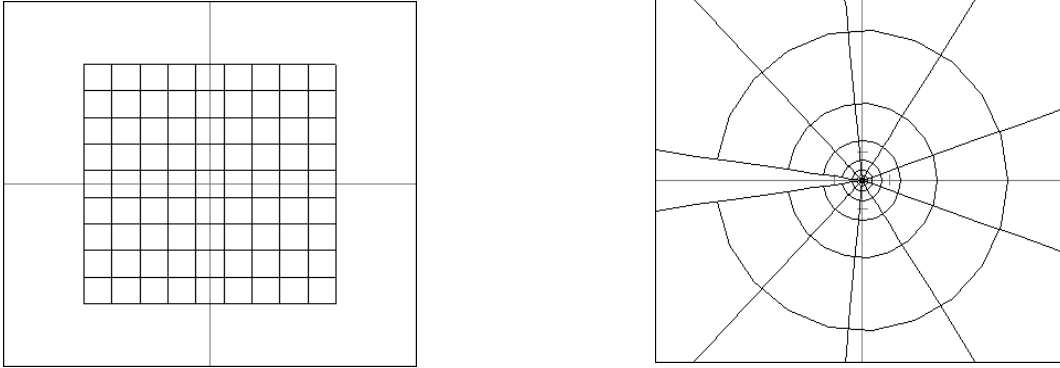


Figure 12.7: The image in the plane of a rectangular grid under e^z .

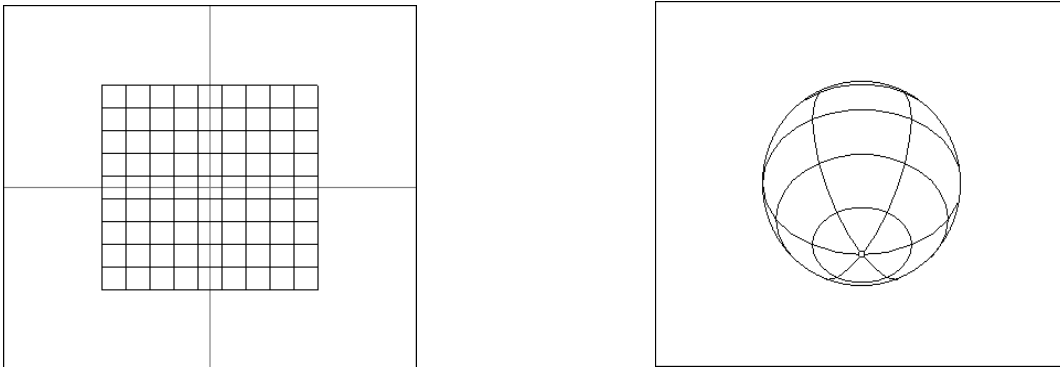


Figure 12.8: The image in the Riemann sphere of a rectangular grid under z^2 .

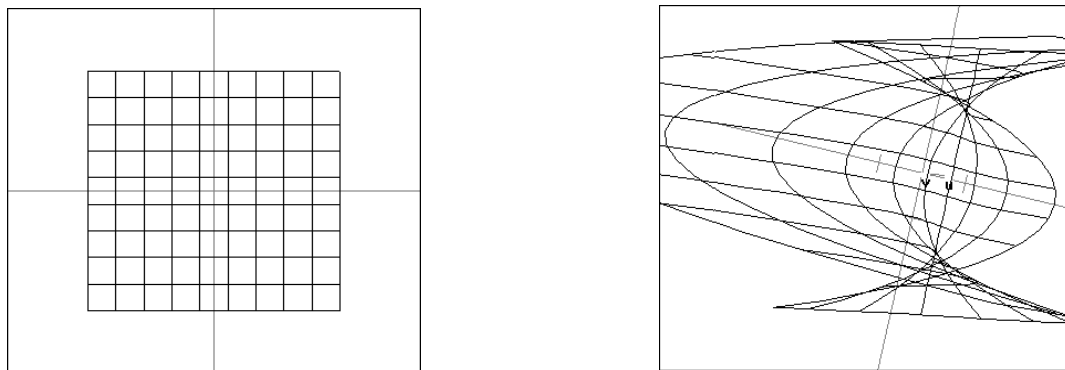


Figure 12.9: The graph in four-space of a rectangular grid acted on by $z^3 - 3z^2 + z - 2$.

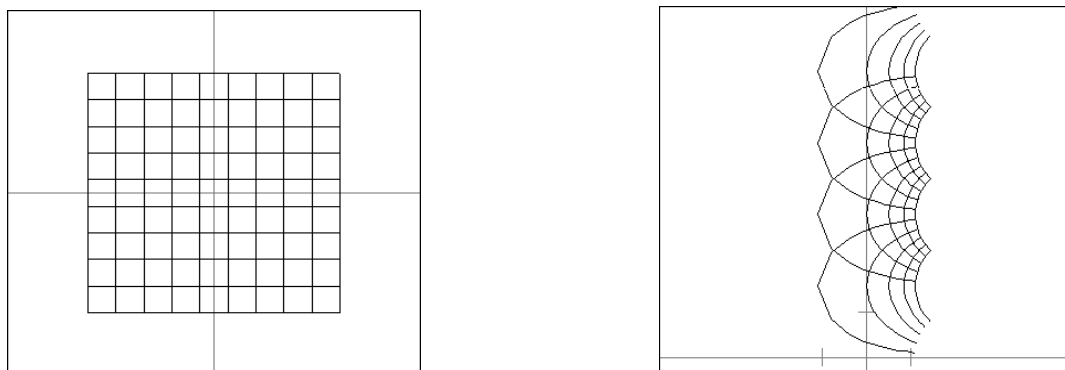


Figure 12.10: The image in the plane of a rectangular grid under $\log z$.

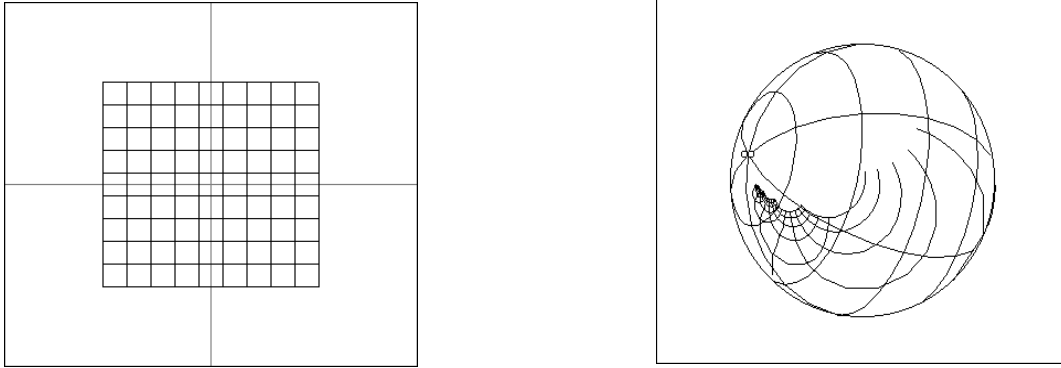


Figure 12.11: The image in the Riemann sphere of a rectangular grid under $\log z$.

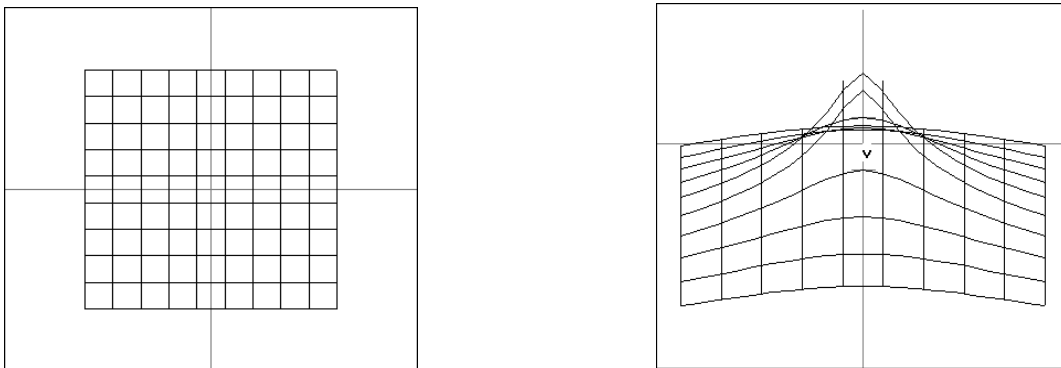


Figure 12.12: The graph in four-space of a rectangular grid acted on by $\log z$.

yields the output $1 + 2I$, which is the correct quotient in the complex field. The commands `Re[z]`, `Im[z]`, `conjugate[z]`, `Abs[z]`, `Arg[z]` compute real part, imaginary part, conjugate, modulus, and argument, respectively.

`Mathematica` can factor a polynomial over the Gaussian integers:¹ for example, the command

```
Factor[1 + x^2, GaussianIntegers -> True]
```

yields the output $(-I + x)(I + x)$.

`Mathematica` can calculate residues. The input

```
Residue[1/z, {z,0}]
```

yields the output 1, while the input

```
Residue[1/z^2, {z,0}]
```

yields the output 0.

`Mathematica` has a number of specialized commands for converting a (complex) mathematical expression from one scientific form to another.

12.1.3 Maple[®]

`Maple` by Waterloo Maple is another all-around mathematics utility. Like `Mathematica`, it can perform computer algebra operations and run numerical analysis routines; it also has powerful graphics capabilities.

In general, `Maple`'s capabilities are similar to those of `Mathematica`. Of course the syntax is different. Details of `Maple` syntax may be found in [CHA].

`Maple` has a command `evalc` that “oversees” a number of basic complex arithmetic operations.

¹A *Gaussian integer* is a number of the form $m + in$ where $m, n \in \mathbb{Z}$.

Examples of Mathematica Commands

Input	Output
<code>Exp[2 + 9I]/N</code>	<code>-6.73239 + 3.04517 I</code>
<code>ComplexExpand[Sin[x + Iy]]</code>	<code>Cosh[y] Sin [x] + I Cos[x] Sinh [y]</code>
<code>TrigToExp[Tan[x]]</code>	<code>[I(E^{-Ix} - E^{Ix})]/[E^{-Ix} + E^{Ix}]</code>
<code>ExpToTrig[Exp[x] - Exp[-x]]</code>	<code>2 Sinh[x]</code>
<code>N[Sqrt[-2I]]</code>	<code>1. - 1.I</code>

Examples of Maple Commands

Input	Output
<code>evalc((3 + 5*I)*(7 + 4*I));</code>	<code>1 + 47 I</code>
<code>evalc(Re((1 + 2*I)*(3 - 4*I)));</code>	<code>11</code>
<code>evalc((-5 + 7*I)/(2 + 3*I));</code>	<code>1 + 2*I</code>
<code>evalc(sin(I));</code>	<code>sinh(1) I</code>
<code>evalc(exp(I));</code>	<code>cos(1) + sin(1) I</code>
<code>evalc(conjugate(exp(2*I)));</code>	<code>cos(2) - sin(2) I</code>
<code>evalc(polar(r,theta));</code>	<code>r cos(theta) + r sin(theta) I</code>

A feature of many of the most popular computer algebra systems is that the user must *tell* the software when complex arithmetic is desired. The command `evalc` is an illustration of that concept.

Maple can convert a complex number from Cartesian form to polar form, expressed either with exponentials or with trigonometric functions.

Using the command `fsolve` with the `complex` option, **Maple** can find all the roots of any polynomial with complex coefficients; the roots are expressed as floating point complex numbers.

Maple can compute the signum of a complex number where $\text{sgn } z$ is defined to be $z/|z|$ when $z \neq 0$. The command is `signum z`.

Maple also has advanced capabilities, such as being able to handle the syntax of the Newman-Penrose conjugation operator. It can treat Hermitian tensors and spinors.

12.1.4 MatLab[®]

The package **MatLab** has the **Maple** kernel imbedded in it. But it has **MatLab**'s powerful front end. Therefore, with **MatLab**, one can perform any complex arithmetic operation that can be performed in **Maple**. See [HAL], [MAT], [MOC] for details of the **MatLab** syntax.

An attractive feature of **MatLab** is that complex numbers do not require special treatment or special formatting. They can be entered (using either i or j for $\sqrt{-1}$) just as one would enter a real number.

12.1.5 Ricci[®]

Ricci is a **Mathematica** package created by John M. Lee. It is available, together with descriptive material, add-ons, and documentation, from the Web site

<http://www.math.washington.edu/~lee/Ricci/>

Ricci is designed to do tensor calculations in differential geometry. As such, it is tangential to the main thrust of the present book. For those who know the formalism of differential geometry, it may be of interest to know that **Ricci** can calculate covariant derivatives, exterior derivatives, Riemannian metrics and curvatures, can manipulate vector bundles, can handle complex bundles and tensors, and conforms to the Einstein summation convention.

When performed by hand, the calculations described in the preceding paragraph are massive—and easily prone to error. *Ricci* is a powerful device for accuracy checking and for performing “what if” experiments in differential geometry. We note that it is *not* a commercial product.

Appendices

Solutions to Odd-Numbered Exercises

Chapter 1

Section 1.1

1. $z + w = 15 - i$, $w - z = 1 - 15i$, $z\zeta = -32 + 123i$, $w\zeta = 56 + 24i$, $\zeta - z = -12 + 4i$
3. $z + \bar{z} = 12$, $z + 2\bar{z} = 18 + 2i$, $z - \bar{w} = 2 + i$, $z\bar{\zeta} = -32 + 4i$, $w\zeta^2 = 66 + 112i$ 5. Identify \mathbb{C} with \mathbb{R}^2 and $z = (x, y)$, then $\bar{z} = (x, -y) =$ reflection about x-axis.
7. $\mathbb{R} = \mathbb{R} \times \{0\}$ 9. $9 - 4i$, $6 + 3i$, $2 - i$ 11. $z + w = (a + c, b + d) = Z + W$, $z \cdot w = re^{i\theta} se^{it} = rse^{i(\theta+t)}$

Section 1.2

1. $|z| = 3\sqrt{13}$, $|w| = 2\sqrt{5}$, $|z + w| = \sqrt{149}$, $|\zeta w| = \sqrt{73}$, $|zw| = 6\sqrt{65}$, $|\zeta z| = 3\sqrt{1313}$ $|z + w| = \sqrt{149} \leq \sqrt{117} + \sqrt{20} = |z| + |w|$ $|zw| = 6\sqrt{65} = (3\sqrt{13})(2\sqrt{5}) = |z||w|$
3. $z = 1$, $w = i$ 5. All discs are shown in Figure 1A.

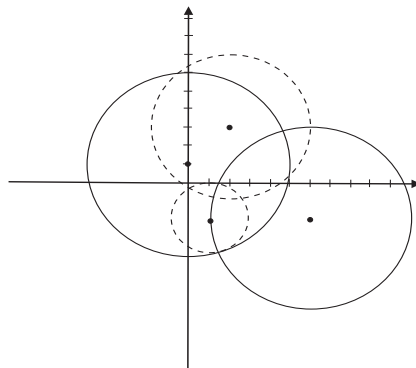


Figure 1A

7. Roots: $1, \sqrt{2}i, -\sqrt{2}i$ and by fundamental theorem of algebra these are all of them.

9. $\sqrt{45} \approx 6.708, \sqrt{20} \approx 4.472, \sqrt{113} \approx 10.6301$ 11. Evaluate the polynomial at the given points. Only i is a root. 13. $p(z) = z^4 + z^3(-20 - 8i) + z^2(157 + 118i) + z(-614 - 600i) + (1668 + 1164i)$. Every polynomial with these roots has the same four linear factors, and no others. 15. If $z = re^{i\theta}$, then $\frac{1}{z} = \frac{1}{r}e^{-i\theta}$, so $\frac{1}{z}$ is a radial reflection about the circle $\{z : |z| = 1\}$ then reflection about the x-axis.

Section 1.3.3

1. $e^{i\pi} = -1, e^{\frac{i\pi}{3}} = \frac{1}{2} + i\frac{\sqrt{3}}{2}, 5e^{-i\frac{\pi}{4}} = \frac{5}{\sqrt{2}} - i\frac{5}{\sqrt{2}}, 2e^i = 2\cos(1) + 2i\sin(1), 7e^{-3i} = 7\cos(3) + 7i\sin(3)$ 3. $z = \log(2\sqrt{2}) - i\frac{\pi}{4}$ 5. Possible angles for w are: $\frac{\pi}{20} + \frac{2\pi k}{5}$ for $k = 0, 1, 2, 3, 4$. 7. If $w = re^{i\theta}, z = se^{i\alpha}$, then, $r^2 = s^3$ and $2\theta = 3\alpha$. 9. $z + w$ has modulus $\sqrt{r^2 + s^2 + 2rs\cos(\theta - \psi)}$ and subtends an angle of $\arctan\left(\frac{r\sin(\theta) + s\sin(\psi)}{r\cos(\theta) + s\sin(\psi)}\right)$

11. $\sqrt{29}e^{-1.19i}, \sqrt{58}e^{1.166i}, \sqrt{50}e^{.588i}$ 13. $\frac{\sqrt{3}}{2} + i\frac{3}{2} \approx .866 + 1.5i, -\sqrt{2} + i\sqrt{6} \approx -1.414 + 2.449i, \frac{\sqrt{15}}{2} + i\frac{\sqrt{5}}{2} \approx 1.936 + 1.118i, \frac{\sqrt{2}}{2} - i\frac{\sqrt{6}}{2} \approx .707 - .225i$ 15. Suppose $e^z = 0$, with $|z| = r \geq 0$. Then, $0 = |e^z| = e^r$ a contradiction.

Section 1.3.6

1. $3^{\frac{1}{3}} \exp\left(\frac{i\pi}{3} + \frac{2\pi ik}{3}\right)$ for $k = 0, 1, 2$. 3. $-i = e^{\frac{3\pi i}{2}}$ 5. $\sqrt{45} \exp(i \arctan(-2))$
 7. If $z = a + ib$, then $|z| = \sqrt{a^2 + b^2} \leq |a| + |b|$ using the fact that $a^2 + b^2 \leq (|a| + |b|)^2$.
 9. Apply the triangle inequality. 11. Cube roots are $e^{i\pi/6} \approx e^{.524i}, e^{i5\pi/6} \approx e^{2.618i}$, and $e^{i9\pi/6} \approx e^{4.712i}$. The cubes of these numbers are, respectively, $e^{1.572i} \approx -0.0001 + i, e^{7.854i} \approx i$, and $0.001 + i$. 13. $2.197 - 0.02i$
 15. $\exp\left(i\left(\frac{\pi}{4} + \frac{2\pi k}{4}\right)\right)$ for $k = 0, 1, 2, 3$.

Chapter 2

Section 2.1

1. (a) $\cos(z) - \frac{z^2 + 2z}{(z+1)^2}, z \neq -1$ (b) $e^{2z-z^3}(2-3z^2) - 2z$ (c) $\frac{(z^2+1)(-\sin z) - 2z\cos(z)}{(z^2+1)^2}$
 (d) $\tan z + z + z(\sec^2 z + 1)$ 3. (a) $2 - 8z^3$ (b) $-\sin z(1 + \sin^2 z) + \cos(z)(\sin 2z)$ (c) $-z\sin(\bar{z})\sin(z)$ (d) $2|z|^2\bar{z} - \bar{z}$ 5. $\frac{\partial z}{\partial z} = \frac{1}{2} \left[\frac{\partial}{\partial x} - i\frac{\partial}{\partial y} \right] (x + iy) = \frac{1}{2} + \frac{1}{2} = 1, \frac{\partial \bar{z}}{\partial z} = \frac{1}{2} \left[\frac{\partial}{\partial x} - i\frac{\partial}{\partial y} \right] (x - iy) = \frac{1}{2} - \frac{1}{2} = 0, \frac{\partial z}{\partial \bar{z}} =$

$\frac{1}{2} \left[\frac{\partial}{\partial x} + i \frac{\partial}{\partial y} \right] (x + iy) = \frac{1}{2} - \frac{1}{2} = 0$, $\frac{\partial \bar{z}}{\partial \bar{z}} = \frac{1}{2} \left[\frac{\partial}{\partial x} + i \frac{\partial}{\partial y} \right] (x - iy) = \frac{1}{2} + \frac{1}{2} = 1$.
 7. $f''(x) = -e^{ix} = -f(x)$ and $g''(x) = -(\cos(x) + \sin(x)) = -g(x)$. 9. $\sec^2(z) - 3e^{3z}$. 11. $g(z) = z^2 \bar{z}^2 / 2 + \cos z$ 13. $k(z) = |z|^4 / 4 + \bar{z} \cos z + z \bar{z}^4 / 4$
 15. $\cos z - e^z$ 17. $\frac{\partial}{\partial \bar{z}} f(z) = 2z \cdot \frac{\partial z}{\partial \bar{z}} - 3z^2 \frac{\partial z}{\partial \bar{z}} = 0$. The real part of f is $u(z) = u(x, y) = x^2 - y^2 - x^3 + 3xy^2$. Finally, $\frac{\partial^2}{\partial z \partial \bar{z}} u = \frac{1}{2} \frac{\partial^2}{\partial z \partial \bar{z}} [z^2 + \bar{z}^2 - z^3 - \bar{z}^3] = \frac{1}{2} \frac{\partial}{\partial z} [2\bar{z} - 3\bar{z}^2] = 0$.

Section 2.2

1. (a) $\Delta f(z) = (\frac{\partial^2}{\partial x^2} + \frac{\partial^2}{\partial y^2})(x) = \frac{\partial^2}{\partial x^2} x = 0$ (b) $\Delta g(z) = (\frac{\partial^2}{\partial x^2} + \frac{\partial^2}{\partial y^2})(x^3 - 3xy^2) = 6x - 6x = 0$ (c) $\Delta h(z) = (\frac{\partial^2}{\partial x^2} + \frac{\partial^2}{\partial y^2})(x^2 + y^2 - 2x^2) = 2 - 2 = 0$
 (d) $\Delta k(z) = (\frac{\partial^2}{\partial x^2} + \frac{\partial^2}{\partial y^2})(e^x \cos(y)) = e^x \cos(y) - e^x \cos(y) = 0$ 3. (a) $v(z) = -e^x \cos(y)$ (b) $v(z) = 3xy^2 - x^3$ (c) $v(z) = \frac{1}{2} e^{2y} \cos(2x)$ (d) $v(z) = x + y$.

5. The matrix has the form

$$A = \begin{pmatrix} a & b \\ -b & a \end{pmatrix},$$

with $\langle a, b \rangle$ a unit vector. Now one may calculate each side directly. 7. Not unique: $x^2 y^2, x^4 y^2 - y^4 x^2$ 9. **MatLab** exercise.

Section 2.3

1. (a) $i\pi + \sin(1) - \sin(-1)$ (b) $\frac{14}{15} - \frac{i}{3} + \cos(1 + i)$ (c) $\frac{(e^2 + ie^4)^4 - (e + ie^2)^4}{4} + e(-1 + e(1 - i) + ie^3) + \ln\left(\frac{e + ie^2 + 1}{e^2 + ie^4 + 1}\right)$ 3. $2\pi i$ 5. $\oint_{\gamma} \frac{1}{z} dz = i\pi$ and $\oint_{\mu} \frac{1}{z} dz = -i\pi$ 7. Suppose that $\gamma : [0, 1] \rightarrow \mathbb{C}$ is the parametrization, $\gamma(0) = \gamma(1)$. Then, $\oint_{\gamma} f(z) dz = \int_0^1 f(\gamma(t)) \gamma'(t) dt = F(\gamma(t))|_0^1 = 0$. 9.

Section 2.4

1.

$$J(P) = \begin{pmatrix} 2 & -2 \\ 2 & 2 \end{pmatrix} = \begin{pmatrix} 2\sqrt{2} & 0 \\ 0 & 2\sqrt{2} \end{pmatrix} \begin{pmatrix} \frac{1}{\sqrt{2}} & -\frac{1}{\sqrt{2}} \\ \frac{1}{\sqrt{2}} & \frac{1}{\sqrt{2}} \end{pmatrix}$$

3. Let $\alpha = \cos(-1) + i \sin(-1)$. Then, $|\alpha| = 1$ and

$$J(P) = \begin{pmatrix} e^2 \cos(-1) & -e^2 \sin(-1) \\ e^2 \sin(-1) & e^2 \cos(-1) \end{pmatrix} = \begin{pmatrix} e^2 & 0 \\ 0 & e^2 \end{pmatrix} \begin{pmatrix} \cos(-1) & -\sin(-1) \\ \sin(-1) & \cos(-1) \end{pmatrix}$$

5. The Jacobian at $P = (x, y)$ is

$$\begin{aligned} J(x, y) &= \begin{pmatrix} 2x & -2y \\ -2y & -2x \end{pmatrix} \\ &= \begin{pmatrix} 4x^2 + 4y^2 & 0 \\ 0 & 4x^2 + 4y^2 \end{pmatrix} \begin{pmatrix} \frac{2x}{4x^2 + 4y^2} & -\frac{2y}{4x^2 + 4y^2} \\ -\frac{2y}{4x^2 + 4y^2} & -\frac{2x}{4x^2 + 4y^2} \end{pmatrix} \\ &:= S(x, y)R(x, y). \end{aligned}$$

Observe S is a dilation matrix and R is a rotation matrix with determinant -1 . 7. Let f be conformal. Let $z(t)$ be a curve in the complex plane and consider its image $w(t) = f \circ z(t)$. Calculate that

$$w'(t) = \frac{1}{2} \left(\frac{\partial f}{\partial x} - i \frac{\partial f}{\partial y} \right) z'(t) + \frac{1}{2} \left(\frac{\partial f}{\partial x} + i \frac{\partial f}{\partial y} \right) \overline{z'(t)}.$$

If angles are preserved (as conformality dictates), then $\arg[w'(t)/z'(t)]$ must be independent of $\arg z'(t)$. Thus

$$\frac{1}{2} \left(\frac{\partial f}{\partial x} - i \frac{\partial f}{\partial y} \right) + \frac{1}{2} \left(\frac{\partial f}{\partial x} + i \frac{\partial f}{\partial y} \right) \frac{\overline{z'(t)}}{z'(t)} \quad (*)$$

has constant argument. As $\arg z'(t)$ varies, the point represented by $(*)$ describes a circle with radius $\frac{1}{2}[(\partial f/\partial x) + i(\partial f/\partial y)]$. The argument cannot be constant on this circle unless the radius vanishes. Thus we have

$$\frac{\partial f}{\partial x} = -i \frac{\partial f}{\partial y}.$$

This is the Cauchy-Riemann equations. So f is holomorphic. 9. By Exercise 7, f is holomorphic. Thus e^f is holomorphic using differentiation by $\partial/\partial \bar{z}$. 11. **MatLab** exercise. 13. We calculate that

$$\frac{\partial}{\partial \mathbf{w}_1} \Phi = (2x, 2y)$$

and

$$\frac{\partial}{\partial \mathbf{w}_1} \Phi = (\sqrt{2}x - \sqrt{2}y, \sqrt{2}x + \sqrt{2}y).$$

These two vectors, evaluated at the point $(1, 0)$, are $(2, 0)$ and $(\sqrt{2}, \sqrt{2})$. The angle between these vectors is $\pi/4$.

Section 2.5

1. (a) $\log(3\sqrt{(2)}) - i\frac{\pi}{4}$ (b) $\log(2) + i\frac{5\pi}{6}$ (c) $\log(2) + i\frac{\pi}{4}$ (d) $\log(2) - i\frac{\pi}{3}$
 (e) $-i\frac{\pi}{2}$ (f) $\log(3\sqrt{(2)}) - i\frac{\pi}{4}$ (g) $\log(\sqrt{(10)}) + i\arctan(-3)$ (h) $\log(2\sqrt{(10)}) + i\arctan(3)$
 3. $(1+i)^{1-i} = (1+i)e^{\frac{\pi}{4}}e^{-i\log(\sqrt{(2)})}$, $i^{1-i} = ie^{\frac{\pi}{2}}$, $(1-i)^i = e^{\frac{\pi}{4}}e^{i\log\sqrt{(2)}}$, $(-3)^{4-i} = 3^4e^{\pi}e^{-i\log(3)}$
 5. $\log|z|$ not well defined at 0 and $\text{Arg}(z)$ ambiguous. 7. $\mathbb{C} \setminus \{x+i0 : x \leq e\}$

Chapter 3

Section 3.1

1. $\frac{1}{2\pi i} \oint_{\gamma} z^2 - z dz = \frac{(\gamma(t))^3}{3} - \frac{(\gamma(t))^2}{2} \Big|_0^{2\pi} = 0$ 3. Let $\gamma(t) = (3/2)e^{it}$, $0 \leq t \leq 2\pi$.
 Then

$$\frac{1}{2\pi i} \oint_{\gamma} \cot z dz = \frac{1}{2\pi i} \oint_{\gamma} \frac{1-z+\dots}{z-z^3/3!+\dots} dz = \frac{1}{2\pi i} \oint_{\gamma} \frac{1}{z} dz = 1.$$

5. For any disc $D \subseteq \Omega$, $0 = \oint_{\partial D} f(z) dz = i \int \int_D \frac{\partial f}{\partial \bar{z}} dx dy$ so $\frac{\partial f}{\partial \bar{z}} = 0$ any disc in Ω . Thus, f holomorphic in Ω . 7. γ deformable to a point in Ω . 9. $-2f(0)$.

11. $\frac{1}{2\pi i} \oint_{\gamma} \frac{1}{(\zeta)(\zeta-P)} d\zeta = \frac{1}{2} \frac{1}{2\pi i} \oint_{\gamma} \frac{1}{\zeta-P} d\zeta - \frac{1}{2} \frac{1}{2\pi i} \oint_{\gamma} \frac{1}{\zeta} d\zeta = \frac{1}{2} - \frac{1}{2} = 0 \neq f(P) = \frac{1}{2}$

13. By deforming γ in U to $\tilde{\gamma}(t) = z + \cos(t) + i\sin(t)$, we have $\frac{1}{2\pi i} \oint_{\gamma} \frac{1}{\zeta-z} d\zeta = \frac{1}{2\pi i} \oint_{\tilde{\gamma}} \frac{1}{\zeta-z} d\zeta = \frac{1}{2\pi i} \int_0^{2\pi} \frac{i(\cos(t)+i\sin(t))}{z+\cos(t)+i\sin(t)-z} dt = \frac{i}{2\pi i} \int_0^{2\pi} dt = 1$

15. **MatLab** exercise. 17. Same as Exercise 16. The aggregate force across the boundary is zero—flow into the region balances flow out of the region.

Section 3.2

Section 3.3

1. **MatLab** exercise. 3. **MatLab** exercise. 5. **MatLab** exercise.

Chapter 4

Section 4.1

1. $\sum_{k=0}^{\infty} \frac{(-1)^k z^{3(2k+1)}}{(2k+1)!}$, $\sum_{k=0}^{\infty} \frac{(-1)^k (z-\pi)^{3(2k+1)}}{(2k+1)!}$ 3. We calculate that

$$\begin{aligned} h(z) &= \frac{z}{z^2 - 1} \\ h'(z) &= \frac{-1 - z^2}{(z^2 - 1)^2} \\ h''(z) &= \frac{2z^5 + 4z^3 - 6z}{(z^2 - 1)^4} \\ h'''(z) &= \frac{-6z^4 - 36z^2 - 6}{(z^2 - 1)^4}. \end{aligned}$$

Thus

$$\begin{aligned} h(2) &= \frac{2}{3} \\ h'(2) &= \frac{-5}{9} \\ h''(2) &= \frac{28}{27} \\ h'''(2) &= \frac{-246}{81}. \end{aligned}$$

It follows that

$$h(z) = \frac{z}{z^2 - 1} = \frac{2}{3} - \frac{5}{9}(z - 2) + \frac{14}{27}(z - 2)^2 - \frac{41}{81}(z - 2)^3 + \dots$$

5. $f = cp$ where c is some constant 7. Write $p(z) = (z - z_0)^2 q(z)$ some polynomial $q(z)$. 9. Let f be the uniform limit of f_n 's Using the Cauchy integral formula, $z \in K$, Γ the boundary of K , we have $\left| f_n^{(m)}(z) - f^{(m)}(z) \right| \leq \frac{m!}{2\pi} \oint_{\Gamma} \left| \frac{f_n(\zeta) - f(\zeta)}{(\zeta - z)^{m+1}} \right| d\zeta$ Now, use the uniform convergence of f_n to f to estimate the numerator of the integrand. 11. By translating, assume $p = 0$ and by scaling, we will assume $r = 1$. Consider $f(z) = z^M$. 13. Write $p(z) = z^k + a_{k-1}z^{k-1} + a_{k-2}z^{k-2} + \dots + a_1z + a_0$. Then

$$p(z) = z^k \left(1 + a_{k-1} \frac{1}{z} + a_{k-2} \frac{1}{z^2} + \dots + a_1 \frac{1}{z^{k-1}} + a_0 \frac{1}{z^k} \right).$$

If z is so large that

$$\left| \frac{1}{z} \right| < \frac{1}{\max_{0 \leq j \leq k-1} \{|a_j| + 1\}} \cdot \frac{1}{10k},$$

then the desired inequality is immediate. 15. $\sum_{k=0}^{\infty} \left(\frac{z-p}{r}\right)^k$ for $r \neq 0, \infty$.

If $r = 0$, $\sum_{k=0}^{\infty} k!(z-p)^k$, $r = \infty$, $\sum_{k=0}^{\infty} \frac{(z-p)^k}{k!}$ 17. We know that

$$\frac{1}{1-\alpha} = 1 + \alpha + \alpha^2 + \alpha^3 + \alpha^4 + \dots$$

Thus

$$\frac{1}{1+\alpha} = 1 - \alpha + \alpha^2 - \alpha^3 + \alpha^4 - + \dots$$

Taking the derivative in α gives

$$\frac{1}{(1+\alpha)^2} = 1 - 2\alpha + 3\alpha^2 - 4\alpha^3 \dots + -.$$

Now multiply both sides by $(1-\alpha)$ to obtain

$$\frac{1-\alpha}{(1+\alpha)^2} = 1 - 3\alpha + 5\alpha^2 - 7\alpha^3 + 9\alpha^4 - + \dots$$

For the last step, we make the substitution $\alpha = z^3$. The end result is

$$\frac{1-z^2}{(1+z^2)^2} = 1 - 3z^2 + 5z^4 - 7z^6 + 9z^8 - + \dots$$

19. MatLab exercise. 21. $f(z) = Ce^{2z}$ any constant C .

Section 4.2

1. Apply 1 of 4.2.3 3. If \mathcal{R} is the zero set of an entire function, there exists an accumulation point hence $f(z) \equiv 0$ contradicting f not identically zero. For the second part, take, e.g., $f(x, y) = y$. 5. $Z(fg) = P \cup Q$. But we can't say anything about $P \cap Q$ or $P \setminus Q$. 7. Fix $z = e^{i\theta}$, then multiplying the denominator by a unimodular constant $|z|$, $|\varphi_c(z)| = \left| \frac{e^{i\theta}-c}{1-\bar{c}e^{i\theta}} \right| = \left| \frac{e^{i\theta}-c}{e^{i\theta}-c} \right| = 1$ If $|z| < 1$, then using $\varphi_c(c) = \frac{c-c}{1-|c|^2} = 0$. Lastly, $\varphi_c(\varphi_{-c}(z)) = \frac{\frac{z+c}{1+\bar{c}z}-c}{1-\bar{c}\frac{z+c}{1+\bar{c}z}} = \frac{z-|c|^2z}{1-|c|^2} = z$ 9. $f(z) = z$ on the disc. 11. 13. Zeros are the points of stationary flow. The uniqueness theorem is saying that

if we know the flow through the real axis, then we know the flow everywhere.

Chapter 5

Section 5.1

1. (a) Pole (b) Removable Singularity (c) Pole. (d) Pole (e) Essential Singularity (f) Removable Singularity (g) Essential Singularity. 3. Yes to both. 5. f has an essential singularity. 7. 9. The removable singularity signifies that the fluid flows smoothly across the point. There is no irregular behavior of the fluid. 11. The essential singularity signifies that the fluid is turbulent near the indicated point.

Section 5.2

1. $\sum_{n=0}^{\infty} \frac{z^{-n}}{n!}$ 3. $-\frac{1}{z-\frac{\pi}{2}} + \frac{1}{3}(z-\frac{\pi}{2}) + \frac{2^4}{3!5!}(z-\frac{\pi}{2})^3 + \frac{3 \cdot 2^7}{3!3!7!}(z-\frac{\pi}{2})^5 + \dots$ 5.

The function f has infinitely many terms of negative index in its Laurent expansion. It follows, by a calculation, that $1/f$ will also have infinitely many terms of negative index. An alternative point of view is this: (i) If f has a pole at 0 then $1/f$ will have a zero at 0. If f has a removable singularity at 0 then $1/f$ will have either a removable singularity or a pole. Thus the reciprocal of an essential singularity is an essential singularity. 7. Cancellation of terms z^{-k} for all $k \leq -M$ some $M \in \mathbb{N}$. Check second part 9. $f(z) = \frac{1}{z} + e^{\frac{1}{z}}$, $g(z) = -e^{\frac{1}{z}}$

Section 5.3

1. We calculate

$$\frac{z - \sin z}{z^6} = \frac{z - [z - z^3/3! + z^5/5! - z^7/7! + \dots]}{z^6} = \frac{1}{3!}z^{-3} - \frac{1}{5!}z^{-1} + \frac{1}{7!}z^{-+} + \dots$$

3. $\sum_{n=0}^{\infty} \frac{(-1)^n z^{-(2n+1)}}{(2n+1)!}$ 5. $e^{f(z)}$ has an essential singularity at 0. 7.

If $N(f)$ = number of poles of f , $Z(f)$ = number of zeroes of f , then $N(f \pm g) \leq N(f) + N(g)$, and $N(fg) \leq N(f) + N(g)$. $N(\frac{f}{g}) \leq N(f) + Z(g)$.

9. (a) Pole (b) Essential singularity (c) Pole (d) Essential singularity (e) Removable singularity (f) Pole (g) Pole 11. Let $A = \{z \in \mathbb{C} : 1 < |z| < 2\}$. The series $\sum_{j=-\infty}^{\infty} z^j/j!$ converges on all of the boundary of A . The series $\sum_{j=-\infty}^1 z^j$ converges on A but on none of the inner boundary of A . The series $\sum_1^{\infty} (z/2)^j$ converges on all of A but on none of the outer boundary. The series $\sum_1^{\infty} 2^{-2j} z^{2j} + \sum_{j=-\infty}^{-1} z^{2j+1}$ converges on all of A but on none of

the boundary. 13. $-\frac{1}{z-\frac{\pi}{2}} + \frac{1}{3}(z-\frac{\pi}{2}) + \frac{2^4}{3!5!}(z-\frac{\pi}{2})^3 + \frac{3 \cdot 2^7}{3!3!7!}(z-\frac{\pi}{2})^5 + \dots$

Section 5.4

1. 1 3. 1 5. 1 7. No conclusion is possible. Let $f(z) = z + 1/z$ and $g(z) = z^2 + 2/z$. 9. If $k \neq -1$ then the residue is 0, if $k = -1$ then the residue is 1. 11. (a) 1 (b) $1 + \frac{e^{-1}}{\sin(-1)} - \frac{e^\pi}{1+\pi} - \frac{e^{-\pi}}{1-\pi}$ (c) $-\frac{\cot(2i)}{16i} + \frac{1}{28} + \frac{1}{(\pi-6i)^2+64} + \frac{1}{(-\pi-6i)^2+64} + \frac{1}{(2\pi-6i)^2+64} + \frac{1}{(-2\pi-6i)^2+64}$ (d) $\frac{1}{e} + \frac{1}{2e^2} - \frac{1}{2}$ (e) $\frac{2e^{-3}}{-3+3i} - \frac{e^{-4}}{(-4+3i)^2}$ 13. If f is bounded in a deleted neighborhood of P then (since g is continuous) $g \circ f$ will be bounded in a neighborhood of P . So $g \circ f$ will have a removable singularity. If f has a pole at P , then it does *not* follow that $g \circ f$ has a pole. Take, for example $f(z) = 1/z$ and $g(z) = 1/z$. If f has an essential singularity at P , then (by examining Laurent series) we can see that $g \circ f$ will have an essential singularity at P .

Section 5.5

1. Use the contour consisting of $\gamma_1(t) = Re^{it}$, $0 \leq t \leq \pi$ and $\gamma_2(t) = -R + R(t-\pi)/\pi$, $\pi < t \leq 2\pi$. Then the poles of $1/(1+z^4)$ inside the curve are at $e^{i\pi/4}$ and $e^{3i\pi/4}$. The respective residues are $e^{-3\pi i/4}/4$ and $e^{-\pi i/4}/4$. The integral over γ_1 vanishes as $R \rightarrow \infty$ and the integral over γ_2 tends to the value that we seek. It is $\pi/\sqrt{2}$. 3. Use the four-part contour consisting of $\gamma_1(t) = t$, $1/R \leq t \leq R$, $\gamma_2(t) = Re^{it}$, $0 \leq t \leq \pi$, $\gamma_3(t) = t$, $-R \leq t \leq -1/R$, and $\gamma_4(t) = (1/R)e^{-it}$, $\pi \leq t \leq 2\pi$. The integrals over γ_1 and γ_4 are easily seen to tend to 0 as $R \rightarrow +\infty$. The integral over γ_1 tend to the value I that we seek. The integral over γ_3 is calculated to be

$$\oint_{\gamma_3} \frac{z^{1/3}}{1+z^2} dz = \int_{-R}^{-1/R} \frac{t^{1/3}}{1+t^2} dt = \int_R^{1/R} \frac{(-t)^{1/3}}{1+t^2} (-1) dt = \int_{1/R}^R \frac{t^{1/4} e^{i\pi/3}}{1+t^2} dt.$$

The only pole inside the contour is at i , and the residue there is $e^{-\pi i/3}/2$. We conclude that

$$(1 + e^{i\pi/3})I = 2\pi i(e^{-i\pi/3}/2).$$

Solving, we find that $I = \pi/\sqrt{3}$. 5. Use the contour consisting of $\gamma_1(t) = Re^{it}$, $0 \leq t \leq 2\pi/3$, $\gamma_2(t) = (R + 2\pi/3 - t)e^{2\pi i/3}$, $2\pi/3 < t \leq 2\pi/3 + R$, and $\gamma_3(t) = t - 2\pi/3 - R$, $2\pi/3 + R < t \leq 2\pi/3 + 2R$. The integral over γ_1 tends to 0. The integral over γ_3 tends to I , the value that we seek. The integral over γ_2 is, after a change of variable, equal to $e^{-2\pi i/3}$ times I . There is a single pole inside the contour at $e^{i\pi/3}$ and the residue there is $e^{-2\pi i/3}/3$. In

sum,

$$(1 - e^{2\pi i/3})I = 2\pi i \cdot \frac{e^{-2\pi i/3}}{3}.$$

Solving, we find that $I = 2\pi/(3\sqrt{3})$. 7. We use the same contour as in Exercise 1. As before, the integral over the upper part of the contour tends to 0. The integral over the lower part of the contour tends to the desired real integral value I . The poles of $z^2/(1+z^4)$ inside the contour are at $e^{i\pi/4}$ and $e^{3\pi i/4}$ and the respective residues are $e^{-i\pi/4}/4$ and $e^{-3\pi i/4}/4$. In sum,

$$I = 2\pi i \left(\frac{e^{-i\pi/4}}{4} + \frac{e^{-3\pi i/4}}{4} \right) = \frac{\pi\sqrt{2}}{2}.$$

9. Use the contour consisting of $\gamma_1(t) = Re^{it}$, $0 \leq t \leq \pi$ and $\gamma_2(t) = -R + R(t - \pi)/\pi$, $\pi < t \leq 2\pi$. Then the poles of $z^2/(1+z^6)$ inside the curve are at $e^{i\pi/6}$, $e^{i\pi/2}$, and $e^{5\pi i/6}$. The respective residues are $-i/6$, $i/6$, and $-i/6$. The integral over γ_1 vanishes as $R \rightarrow \infty$ and the integral over γ_2 tends to the value that we seek. It is $\pi/3$. 11. Similar to Example 5.5.4 in the text.

Section 5.6

1. The function f has a pole of order k at ∞ if $f(1/z)$ has a pole of order k at 0. If g has a pole of order k at ∞ then $1/g$ has a zero of order k at ∞ . The function $1/g(1/z)$ then has a zero of order k at 0. 3. Using the method of partial fractions, and some simple changes of variable, one is reduced to considering the two particular rational functions

$$r_1(z) = \frac{1}{z} \quad \text{and} \quad r_2(z) = \frac{1}{1+z^2}.$$

The assertion in these two cases may be calculated directly. 5. The function $f(z) = 1/\sin(iz)$ satisfies this condition. 7. Let $\{p_j\}$ be the collection of poles of f . Then these are the zeros of the function $g = 1/f$. If there is an interior accumulation point then the function g must be identically zero. That is a contradiction.

Chapter 6

Section 6.1

1. Say $p(z) = z^n + a_{n-1}z^{n-1} + \cdots + a_0$. Then, for R large for $|z| = R$, $\left| \frac{p'(z)}{p(z)} \right| \leq n$
3. Use the hint and the fact that the convex hull of the zeroes is the intersection of the half-planes containing the zeroes. 5. Set $g(z) = f(z) - f(P)$, then g is not one to one on any neighborhood of P thus the same is true of f .
7. If z_i are the roots of p_{t_0} there is an r st $D(z_i, r) \cap D(z_j, r) = \emptyset$ if $i \neq j$. Then, $1 = \frac{1}{2\pi i} \int_{D(z_i, r)} \frac{p'_i(z)}{p_i(z)} dz$ if $|t - t_0| < \epsilon_i$, taking $\epsilon = \min_i \epsilon_i$ if $|t - t_0| < \epsilon$, then p_t has the same number of zeros of p_{t_0} . 9. MatLab exercise. 11. MatLab exercise.

Section 6.2

1. Let $f : U \rightarrow \mathbb{C}$ with $\overline{D(P, r)} \subset U$. Suppose f has infinitely z in $D(P, r)$ with $f(z) = 0$, then these zeros have an accumulation point $z_0 \in \overline{D(P, r)}$. The $f \equiv 0$ on some neighborhood of z_0 so, f identically 0 on $D(P, r)$ a contradiction.
3. $\frac{(e^z)'}{e^z} = 1$ giving $\frac{1}{2\pi i} \int_{D(0, r)} \frac{(e^z)'}{e^z} dz = 0$ 5. $f(D)$ open connected with $0 \notin f(D)$ so $\frac{f'}{f}$ holomorphic. Setting $g(z) = \log(f(0)) + \int_0^z \frac{f'(z)}{f(z)} dz$ satisfies the differential equation and it's easy to verify that $g(z) = \log(f(z))$ for $z \in D$.
7. Since f and g uniformly close on $\partial D(P, r)$, we can pick $0 < \epsilon \ll 1$ with $|\frac{g}{f} - 1| < \frac{\epsilon}{2\pi r \max_{\partial D(P, r)} (\frac{f'}{g})}$ on $\partial D(P, r)$. Now $\frac{1}{2\pi i} \int_{\partial D(P, r)} \frac{g'}{f} - \frac{g}{f} = \frac{1}{2\pi i} \int_{\partial D(P, r)} \left(\frac{f'}{g} \right)' \frac{g}{f} = \text{number zeros } g - \text{number zeroes } f$ in $D(P, r)$ but the absolute value of the above expression is less than $\epsilon \ll 1$ hence it must be zero. 9. Fix a point z_0 in U and, for any $z \in U$, define

$$\log f(z) = \int_{\gamma} \frac{f'(z)}{f(z)} dz.$$

Here γ is any curve connecting z_0 to z . The definition is unambiguous, and independent of the choice of γ , by the Cauchy integral theorem.

Section 6.3

1. 3 zeros 3. If f is the limit, then if U open, $U \cap \mathbb{R} \neq \emptyset$, then $f \equiv 0$ on U hence, $f \equiv 0$. 5. Set $g(z) = 1 + z$, $|e^z - g(z)| \leq e - 2 < 1 \leq |g(z)|$ on ∂D , apply Rouché's theorem. 7. (a) 8 (b) 1 (c) 9. Note that the convergence of the power series for $\sin z$ is only guaranteed to be uniform on compact sets

where the partial sums are non-zero. Also, the partial sums are not nowhere vanishing. 11. **MatLab** exercise.

Section 6.4

1. $|f(z)| \leq |g(z)|$ on U 3. $z(z - \frac{1}{2})(z + \frac{1}{2})$ 5. (a) $\frac{1-z}{1+z} = \frac{1-w}{1+w}$ iff $(1-z)(1+w) = (1+z)(1-w)$ iff $2z = 2w$. 7. $|g(z)| = |e^{Re f(z)} e^{i Im f(z)}| = e^{Re f(z)}$ hence max of $|g(z)|$ occurs when max occurs for $Re f(z)$ since the real value function e^x is increasing. Apply the maximum principle to $g(z)$. For $Im f(z)$ consider $g(z) = e^{-if(z)}$ 9. By subtracting off a polynomial of degree k , we may suppose that f vanishes to order k at the origin. Now examine the function $g(z) = f(z)/z^k$ and use the hypothesis to apply Liouville's theorem. 11. **MatLab** exercise.

Section 6.5

1. Let $f : \mathcal{U} \rightarrow \mathcal{U}$ satisfy $f(i) = 0$. Then $\psi \circ f \psi^{-1}$ satisfies the hypotheses of the Schwarz lemma as stated in the text. The desired conclusions on \mathcal{U} then follow. 3. The function $f(z) = z^k$ satisfies $f : \mathbb{C} \rightarrow \mathbb{C}$, f is surjective, and $f(0) = 0$. Yet no estimate in the vein of the Schwarz lemma is satisfied. The reason for this failure is that the plane \mathbb{C} is not conformally equivalent to any bounded domain. A nearly equivalent reason is that the plane does not support a conformally invariant metric. 5. Certainly $|g'(0)| \leq 1$ by the classical Schwarz lemma in the text. Now make a substitution for the independent variable to obtain the desired result. 7. Let $\delta > 0$ be the distance of P to the boundary of U . Then the disc $D(P, \delta) \subseteq U$. Define $g(\zeta) = (1/M)f(P + \delta\zeta)$. Then $g : D(0, 1) \rightarrow D(0, 1)$. Hence Schwarz applies and $|g'(0)| \leq 1$. Unraveling the notation we find that $|f'(P)| \leq M/\delta$. 9. **MatLab** exercise.

Chapter 7

Section 7.1

1. A conformal self-map of the plane has the form $\varphi(z) = az + b$. So two points will determine a and b . 3. First assume that the mapping is bounded near 0 and 1. By the Riemann removable singularities theorem, any conformal self-map of this region will extend holomorphically across 0 and 1. So this is a conformal self-map of the plane that takes $\{0, 1\}$ to $\{0, 1\}$. If it takes 0 to 0 then it must be the identity. If it takes 0 to 1 then it must be

$\varphi(z) = 1 - z$. So there are two such conformal mappings. If the mapping is unbounded near 0 then it must have a simple pole at 0. Hence the mapping is $z \mapsto 1/z$. If the mapping is unbounded near 1 then it must have a simple pole at 1. So the mapping is $z \mapsto 1/(1 - z)$. 5. We know that $f(i\pi/2) = i$. If w is near i then we may write $w = re^{i\theta}$ with θ between $\pi/3$ and $2\pi/3$ and $1/2 < r < 2$. Thus $\log r$ is well defined as a real number and $\log r + i\theta$ is $f^{-1}(i)$. Of course there are other inverse images of the form $\log r + i(\theta + 2\pi)$. 7. The image is the set of points of the form $e^{x+iy} = e^x \cdot e^{iy}$ for $0 < x < 1$. Thus the image annulus is $A = \{w \in \mathbb{C} : 1 < |w| < e\}$. The function is not onto because $x + iy$ and $x + i(y + 2k\pi)$ have the same image. The function is locally one-to-one because it has nonvanishing derivative. 9. The map $\varphi(z) = (i - z)/(i + z)$ maps the upper half-plane to the unit disc. One may then calculate that it maps the first quadrant to the upper half disc. Finally, the upper half-plane is conformally equivalent to the first quadrant by way of a square root and a rotation. 11. MatLab exercise.

Section 7.2

1. We calculate:

$$\left| \frac{z - a}{1 - \bar{a}z} \right|^2 < 1$$

iff

$$|z - a|^2 < |1 - \bar{a}z|^2$$

iff

$$|z|^2 - 2\operatorname{Re}\bar{a}z + |a|^2 < 1 - 2\operatorname{Re}\bar{a}z + |az|^2$$

iff

$$|z|^2(1 - |a|^2) < (1 - |a|^2)$$

iff

$$|z|^2 < 1.$$

3. We may as well assume, after composition with suitable Möbius transformations, that $a_1 = 0$ and $b_1 = 0$. But then Schwarz's lemma tells us that the function must be a rotation. If $|a_2| \neq |b_2|$ then a rotation cannot take a_2 to b_2 . 5. These will be all maps of the form $\psi \circ \varphi$, for φ a conformal self-map of the disc. 7. By the Riemann removable singularities theorem, such a conformal map will continue analytically across the origin. So the map is a conformal self-map of the disc that fixes the origin. Thus it must be a rotation.

9. **MatLab** exercise.

Section 7.3

1. We solve

$$\begin{aligned} w &= \frac{i-z}{i+z} \\ w(i+z) &= i-z \\ z(w+1) &= i-iw \\ z &= i \frac{1-w}{1+w}. \end{aligned}$$

3. Map V to the upper half-plane by way of translation and a rotation. Thus reduce the question to classifying all the conformal self-maps of the upper half-plane. 5. A linear fractional transformation can be written as

$$z \mapsto \frac{\alpha z + \beta}{\gamma z + 1}.$$

Thus there are three free parameters. It takes three points to uniquely determine such a transformation. 7. The linear fractional transformations that preserve the unit circle are of course the Möbius transformations

$$z \mapsto \frac{z-a}{1-\bar{a}z},$$

the rotations

$$z \mapsto e^{i\theta} \cdot z,$$

and inversion

$$z \mapsto \frac{1}{z}.$$

And of course we must include compositions of these. The linear fractional transformations that preserve the real line can now be obtained by composition with the Cayley transform. 9. If ℓ maps ∞ to a finite point in the plane and ℓ maps every point of L to a finite point in the plane then the image is a circle. But if some point gets mapped to ∞ then the image is a line. 11. **MatLab** exercise.

Section 7.4

1. There are many reasons. One is that Liouville's theorem rules out the

possibility of a bounded entire function (that is, a map from the plane to the disc). There are also elegant answers in terms of invariant metrics. 3. If there were two such maps, say φ and $\tilde{\varphi}$, then $\psi \equiv \varphi^{-1} \circ \tilde{\varphi}$ would be a conformal self-map of the disc that takes 0 to 0. Thus ψ must be a rotation. If the derivative at the origin is positive it is then the identity. 5. Look at the image of the inner circle:

$$\frac{1}{2}e^{i\theta} \mapsto \frac{1}{2}e^{i\theta} + 2e^{-i\theta} = \frac{5}{2}\cos\theta - \frac{3}{2}\sin\theta.$$

This is plainly an ellipse. A similar calculation shows that the outer circle is mapped to the same ellipse. The answer to the remainder of the question is straightforward. 7. Map the quarter-plane to the half-plane by squaring. Then map the half-plane to the disc with the Cayley map. 9. Map the strip to an annulus with an exponential. The conformal self-maps of an annulus are well known (that is, rotations and inversion).

Section 7.5

1. The mappings $z \mapsto 2z$ and $z \mapsto 2/z$ both map A_1 to $A - 2$ and take 1 to 2. They also both take -1 to -2 . It takes three points to uniquely determine a conformal mapping of these domains. 3. Since circles and lines go to circles and lines, the image could be another (conformal) annulus or it could be a disc. But the mapping to a disc could not be one-to-one, so it must be an annulus. 5. It is an annulus with radii e and e^2 . It will not be one-to-one; in fact it is infinitely many to one. 7. Refer to the answer to Exercise 1. 9. MatLab exercise.

Section 7.6

Chapter 8

Section 8.1 No exercises.

Section 8.2 No exercises.

Section 8.3 No exercises.

Section 8.4

1. Map the first quadrant to the upper half-plane by squaring. Map the

upper half-plane to the disc with the Cayley map. 3. If the initial heat distribution on the boundary is not identically zero then let $P \in \partial D$ be a point where the initial temperature is positive. By the solution of the Dirichlet problem, points in the disc near P will have positive temperature. That is a mathematical reason for the assertion. A physical reason is that the system will have nonzero potential energy. 5. The steady state heat distribution is $\Phi(re^{i\theta}) = r \sin \theta$. This can also be expressed as $\Phi(z) = \frac{z - \bar{z}}{2}$. 7. The steady state heat distribution is $\Phi(re^{i\theta}) = r^5 \cos 5\theta$. This can also be expressed as $\Phi(z) = \frac{z^5 + \bar{z}^5}{2}$. 9. The fact that the initial data is smooth means that there are no jumps or abrupt changes in the data. Since heat at a given point is an average of nearby temperatures, we would expect this property to propagate to the interior. 11. MatLab exercise. 13. Reader should supply details.

Chapter 9

Section 9.1

1. $u_1 + iv = u_2 + iv = f$ holomorphic. By the Cauchy Riemann equations, $\frac{\partial u_1}{\partial x} = \frac{\partial v}{\partial y} = \frac{\partial u_2}{\partial x}$ so $u_1 = u_2 + c(y)$, $c(y)$ a function of y . Applying the Cauchy Riemann equations again gives us that $\frac{\partial c}{\partial y} = 0$ so c is constant. 3. $u \equiv 0$ on each connected component with non-empty intersection with V . 5.

$$\Delta u = e^x (\cos y - \cos y) = 0. \quad v = e^x \sin y.$$

$$7. \Delta u^2 = 2 \left[\left(\frac{\partial u}{\partial x} \right)^2 + \left(\frac{\partial u}{\partial y} \right)^2 \right] + u \Delta u = 2 \left[\left(\frac{\partial u}{\partial x} \right)^2 + \left(\frac{\partial u}{\partial y} \right)^2 \right], \text{ since } u \text{ harmonic.}$$

Since u^2 harmonic, $\left(\frac{\partial u}{\partial x} \right)^2 = - \left(\frac{\partial u}{\partial y} \right)^2$, hence $\left(\frac{\partial u}{\partial x} \right)^2 = 0$ and $\left(\frac{\partial u}{\partial y} \right)^2 = 0$, so $\frac{\partial u}{\partial x} = 0 = \frac{\partial u}{\partial y}$ which means u constant. 9. $\Delta |u|^p = p(p-1)|u|^{p-2}(u_x + u_y) + p|u|^{p-1}\Delta u = p(p-1)|u|^{p-2}\nabla u$

$$11. \text{ If } f \text{ holomorphic, then using } \Delta f = 0 \text{ and } \frac{\partial f}{\partial \bar{z}} = 0: \Delta \log |f| = -\frac{1}{|f|^2} \left[4 \frac{\partial f}{\partial z} \frac{\partial f}{\partial \bar{z}} \right] + \frac{1}{|f|} \Delta f = 0$$

13. MatLab exercise.

Section 9.2

$$1. u(x, y) = x + iy \text{ on } D(0, 1). \text{ Since } u \text{ harmonic, } |u(P)| = \left| \frac{1}{2\pi} \int_0^{2\pi} u(P + re^{it}) dt \right| \leq \frac{1}{2\pi} \int_0^{2\pi} |u(P + re^{it})| dt \quad 3. \quad 0 = u(0) = \frac{1}{2\pi} \int_0^{2\pi} e^{i \sin t} \cos(t) dt =$$

$\frac{1}{2\pi i} e^{i \sin t} \Big|_0^{2\pi} = 0$ 5. Since u harmonic, $|u(P)|^2 \leq \left(\int_0^{2\pi} u(P + re^{it}) \frac{dt}{2\pi} \right)^2 \leq \int_0^{2\pi} |u(P + re^{it})|^2 \frac{dt}{2\pi}$ by Jensen's inequality. 7. Differentiate the first alternative formulation with respect to r . 9. MatLab exercise. 11. MatLab exercise.

Section 9.3

1. This is an elementary calculus exercise and we omit the details. 3. Let $z = re^{i\theta} \in D$ and $\zeta = e^{i\psi} \in \partial D$. We have

$$\begin{aligned} \operatorname{Re} \left[\frac{1}{2\pi i} \frac{1}{\zeta - z} d\zeta - \frac{1}{4\pi} \right] &= \operatorname{Re} \left[\frac{1}{2\pi i} \frac{1}{e^{i\psi} - re^{i\theta}} i e^{i\psi} d\psi \right] \\ &= \frac{1}{2\pi} \operatorname{Re} \frac{1 - re^{-i(\theta-\psi)}}{|1 - re^{i(\theta-\psi)}|^2} - \frac{1}{4\pi}. \end{aligned}$$

Applying some algebraic simplifications we find that this last equals

$$\frac{1}{4\pi} \left[\frac{1 - r^2}{|1 - re^{i(\theta-\psi)}|^2} \right] = \frac{1}{2} P_r(e^{i(\theta-\psi)}).$$

5. The heat value at the origin will be the average of the boundary values, or zero. On the upper half of the disc, the positive boundary values will exert the greatest influence and the temperatures will be positive. On the lower half of the disc, the the negative boundary values will exert the greatest influence and the temperatures will be negative. 7. Now $\sin 2t = \frac{1}{2i}[e^{2it} - e^{-2it}]$. Hence the solution of the Dirichlet problem for this boundary data is $\Phi(z) = \frac{1}{2i}[z^2 - \bar{z}^2]$. We write $\cos^2 t = [1 + \cos 2t]/2 = \frac{1}{2} + \frac{1}{4}[e^{2it} + e^{-2it}]$. Hence the solution of the Dirichlet problem for this boundary data is $\Phi(z) = \frac{1}{2} + \frac{1}{4}[z^2 + \bar{z}^2]$.

Chapter 10

Section 10.1

1.

(a)

$$\widehat{f}(j) = \begin{cases} -\frac{2\pi}{ij} + \frac{2}{j^2} & j \neq 0 \\ \frac{4\pi^2}{3} & j = 0 \end{cases}$$

(b)

$$\widehat{f}(j) = \begin{cases} \frac{1}{2} & j = 2, -2 \\ 0 & \text{else} \end{cases}$$

(c) The coefficient $b_4 = 3$. All other a_j and b_j are 0.

(d) $\widehat{f}(j) = \frac{1}{2\pi(1-ij)}[e^{1-2\pi ij} - 1]$

(e)

$$\widehat{f}(j) = \begin{cases} \frac{1}{4i} & j = 2 \\ -\frac{1}{4i} & j = -2 \\ 0 & \text{else} \end{cases}$$

(f)

$$\widehat{f}(j) = \begin{cases} -\left(\frac{\pi}{2} + \frac{1}{4}\right) & j = -1 \\ -1 & j = 0 \\ -\left(-\frac{\pi}{2} + \frac{1}{4}\right) & j = 1 \\ \frac{1}{j^2-1} & \text{else} \end{cases}$$

(g)

$$\widehat{f}(j) = \begin{cases} \frac{1}{2i} & j = 1 \\ -\frac{1}{2i} & j = -1 \\ -\frac{1}{4i} & j = 3 \\ \frac{1}{4i} & j = -3 \\ 0 & \text{else} \end{cases}$$

3. $\frac{4}{3} + \sum_{n \neq 0} \frac{32}{\pi^2 n^2} e^{\frac{\pi i n}{2}}$ 5. $1 + \frac{16}{i} \operatorname{Im}(\ln[(1 + \zeta)(1 - \zeta)])$ 7. $-\frac{\cos(t)}{2} + \frac{\sin(t)}{2}$

Section 10.2

1. $\frac{-2\pi}{\sqrt{2-i}\sqrt{2}} \exp(\xi\pi\sqrt{2}(1+i))$ 3. Imitate Example 59 in the text.

Section 10.3 No exercises.

Section 10.4

1. (a) $\frac{2}{s^3}$ (b) $\frac{2}{s^2+4}$ (c) $\frac{s}{s^2+9}$ (d) $\frac{1}{s-4\log(\epsilon)}$ (e) $\frac{s^2-16}{(s^2+16)^2}$ (f) $\frac{1}{(s+1)^2+1}$ 3. $(f(0) + \frac{1}{2}) \cos(\sqrt{3}t) + \left(\frac{f'(0)}{\sqrt{3}} + \frac{1}{2\sqrt{3}}\right) \sin(\sqrt{3}t) + \frac{1}{2}e^t$

Chapter 11

Section 11.1

1. We have

$$a_n = \frac{1}{\pi} \int_{-\pi}^{\pi} \pi \cos nx \, dx = \begin{cases} (-1)^j & \text{if } n = 2j - 1 \\ 0 & \text{if } *n = 2j, \end{cases}$$

$$b_n = \frac{1}{\pi} \int_{-\pi}^{\pi} \pi \sin nx \, dx = \begin{cases} -\frac{1}{n} & \text{if } n = 2j - 1 \\ \frac{(-1)^{j+1}}{n} + \frac{1}{n} & \text{if } n = 2j, \end{cases}$$

$$a_0 = \frac{1}{2\pi} \int_{-\pi}^{\pi} \pi \, dx = \frac{3}{4}.$$

3. We have

$$a_n = \frac{1}{\pi} \int_0^{\pi} \sin x \cos nx \, dx = \cdots = \frac{1}{1-n^2} \frac{1}{\pi} [(-1)^{n+1} + 1],$$

$$b_n = \frac{1}{\pi} \int_0^{\pi} \sin x \sin nx \, dx = \cdots = 0,$$

$$a_0 = \frac{1}{2\pi} \int_0^{\pi} \sin x \, dx = \cdots = \frac{1}{\pi}.$$

5. (a) $a_0 = \pi$, $a_n = 0$, $b_n = 0$ (b) $a_0 = 0$, $a_n = 0$, $b_n = 0$ for $n \neq 1$, $b_1 = 1$
 (c) $a_0 = 0$, $a_n = 0$ for $n \neq 1$, $a_1 = 1$, $b_n = 0$ (d) $a_0 = 1$, $a_1 = 1$, $b_1 = 1$, all other coefficients are 0

7. We calculate

$$a_0 = \frac{1}{2\pi} \left[\int_{-\pi}^0 -\pi \, dx + \int_0^{\pi} x \, dx \right] = \cdots = -\frac{\pi}{4},$$

$$a_n = \frac{1}{\pi} \left[\int_{-\pi}^0 -\pi \cos nx \, dx + \int_0^{\pi} x \cos nx \, dx \right] = \cdots = \frac{1}{\pi} \left[\frac{(-1)^n}{n^2} - \frac{1}{n^2} \right],$$

$$b_n = \frac{1}{\pi} \left[\int_{-\pi}^0 -\pi \sin nx \, dx + \int_0^{\pi} x \sin nx \, dx \right] = \cdots = \frac{1}{n} + \frac{2(-1)^{n+1}}{n}.$$

Thus the Fourier series is

$$f(x) \approx -\frac{\pi}{4} + \sum_{n=1}^{\infty} \left(\frac{1}{\pi} \left[\frac{(-1)^n}{n^2} - \frac{1}{n^2} \right] \right) \cos nx + \sum_{n=1}^{\infty} \left(\frac{1}{n} + \frac{2(-1)^{n+1}}{n} \right) \sin nx.$$

At $x = -\pi$, the cosine series is

$$\sum_{n=1}^{\infty} \frac{1}{\pi} \left[\frac{1}{n^2} - \frac{(-1)^n}{n^2} \right].$$

This series converges. The sine series is

$$\sum_{n=1}^{\infty} \left[\frac{1}{n} + \frac{2(-1)^{n+1}}{n} \right] \cdot 0 = 0.$$

At $x = \pi$ the result is the same. It may be proved that at both these endpoints the series converges to a number which is *not* equal to the actual value of the function. 9. Straightforward calculation. 11. We calculate

$$a_0 = \frac{1}{2\pi} \int_{-\pi}^{\pi} \cos \frac{x}{2} dx = \cdots = \frac{2}{\pi},$$

$$a_n = \frac{1}{\pi} \int_{-\pi}^{\pi} \cos \frac{x}{2} \cos nx dx = \cdots = \frac{4}{\pi} \cdot \frac{(-1)^n}{1 - 8n^2},$$

$$b_n = \frac{1}{\pi} \int_{-\pi}^{\pi} \cos \frac{x}{2} \sin nx dx = 0.$$

This last is true because $\sin nx$ is odd while $\cos x/2$ is even hence their product is even. In summary

$$f(x) \approx \frac{2}{\pi} + \sum_{n=1}^{\infty} \frac{4}{\pi} \cdot \frac{(-1)^n}{1 - 8n^2} \cos nx.$$

13. We have

$$\begin{aligned} \sin 3x &= \sin x \cos 2x + \cos x \sin 2x = \sin x(\cos^2 x - \sin^2 x) + \cos x(2 \sin x \cos x) \\ &= \sin x(\cos^2 x - \sin^2 x) + \cos x(2 \sin x \cos x) = 3 \sin x - 3 \sin^3 x - \sin^3 x. \end{aligned}$$

Hence $\sin^3 x = \frac{3}{4} \sin x - \frac{1}{4} \sin 3x$. The proof of $\cos^3 x = \frac{3}{4} \cos x + \frac{1}{4} \cos 3x$ is nearly identical. The statement about Fourier series follows from the uniqueness of the Fourier series expansion. 15. For Fourier series on the interval $[-L, L]$, a simple change of variables shows that

$$a_0 = \frac{1}{2L} \int_{-L}^L f(x) dx,$$

$$a_n = \frac{1}{L} \int_{-L}^L f(x) \cos \frac{n\pi x}{L} dx,$$

$$b_n = \frac{1}{L} \int_{-L}^L f(x) \sin \frac{n\pi x}{L} dx.$$

Then the given formula is a direct calculation. 17. After a change of variables, we may as well suppose that the given circle is the circle of center 0 and radius 1. But then any harmonic function as described is spanned

by the functions $1, z^n, \bar{z}^n$. Each of these functions satisfies the stated “mean value property,” hence so does the harmonic function. 19. The mapping $z \mapsto Rz$ sends the disc $D(0, 1)$ to the disc $D(0, R)$. Thus the given assertions are a simple change of variable. 21. **MatLab** exercise. 23. We have

$$\begin{aligned}
 (f * g)\widehat{(n)} &= \frac{1}{2\pi} \int_{-\pi}^{\pi} \frac{1}{2\pi} \int_{-\pi}^{\pi} f(x-t)g(t) dt e^{-inx} dx \\
 &= \frac{1}{2\pi} \int_{-\pi}^{\pi} \frac{1}{2\pi} \int_{-\pi}^{\pi} f(x-t)g(t) dt e^{-in(x-t)\xi} e^{-int} dx \\
 &= \frac{1}{2\pi} \int_{-\pi}^{\pi} \frac{1}{2\pi} \int_{-\pi}^{\pi} f(x-t)e^{-in(x-t)} dx g(t)e^{-int} dt \\
 &= \frac{1}{2\pi} \int_{-\pi}^{\pi} \frac{1}{2\pi} \int_{-\pi}^{\pi} f(x)e^{-inx} dx g(t)e^{-int} dt \\
 &= \frac{1}{2\pi} \int_{-\pi}^{\pi} f(x)e^{-inx} dx \frac{1}{2\pi} \int_{-\pi}^{\pi} g(t)e^{-int} dt \\
 &= \widehat{f}(n) \cdot \widehat{g}(n).
 \end{aligned}$$

25. **MatLab** exercise. 27. **MatLab** exercise. 29. These results follow from the uniqueness of Fourier series. 31. Imitate the text.

Chapter 12 No exercises.

Glossary of Terms from Complex Variable Theory and Analysis

This glossary contains all the terms from complex variable theory that are introduced in this text. But it contains a number of other common terms from the subject as well. We hope that the comprehensive nature of this collection of terms will make it more useful.

accumulation point Let a_1, a_2, \dots be points in the complex plane. A point b is an accumulation point of the a_n if the a_n get arbitrarily close to b . More formally, we require that for each $\epsilon > 0$ there exists an $N > 0$ such that when $n > N$ then $|a_n - b| < \epsilon$.

analytic continuation The procedure for enlarging the domain of a holomorphic function.

analytic continuation of a function If $(f_1, U_1), \dots, (f_k, U_k)$ are function elements and if each (f_n, U_n) is a direct analytic continuation of (f_{n-1}, U_{n-1}) , $n = 2, \dots, k$, then we say that (f_k, U_k) is an *analytic continuation* of (f_1, U_1) .

analytic continuation of a function element along a curve An *analytic continuation* of (f, U) along the curve γ is a collection of function elements (f_t, U_t) , $t \in [0, 1]$, such that

- 1) $(f_0, U_0) = (f, U)$;

- 2) For each $t \in [0, 1]$, the center of the disc U_t is $\gamma(t)$, $0 \leq t \leq 1$;
- 3) For each $t \in [0, 1]$, there is an $\epsilon > 0$ such that, for each $t' \in [0, 1]$ with $|t' - t| < \epsilon$, it holds that
- (a) $\gamma(t') \in U_t$ and hence $U_{t'} \cap U_t \neq \emptyset$;
- (b) $f_t \equiv f_{t'}$ on $U_{t'} \cap U_t$ (so that (f_t, U_t) is a direct analytic continuation of $(f_{t'}, U_{t'})$).

annulus A set of one of the forms $\{z \in \mathbb{C} : 0 < |z| < R\}$ or $\{z \in \mathbb{C} : r < |z| < R\}$ or $\{z \in \mathbb{C} : r < |z| < \infty\}$.

area principle If f is schlicht and if

$$h(z) = \frac{1}{f(z)} = \frac{1}{z} + \sum_{n=0}^{\infty} b_n z^n$$

then

$$\sum_{n=1}^{\infty} n|b_n|^2 \leq 1.$$

argument If $z = re^{i\theta}$ is a complex number written in polar form then θ is the argument of z .

argument principle Let f be a function that is holomorphic on a domain that contains the closed disc $D(P, r)$. Assume that no zeros of f lie on $\partial D(P, r)$. Then, counting the zeros of f according to multiplicity,

$$\frac{1}{2\pi i} \oint_{\partial D(P, r)} \frac{f'(\zeta)}{f(\zeta)} d\zeta = \# \text{ zeros of } f \text{ inside } D(P, r).$$

argument principle for meromorphic functions Let f be a holomorphic function on a domain $U \subseteq \mathbb{C}$. Assume that $\overline{D(P, r)} \subseteq U$, and that f has

neither zeros nor poles on $\partial D(P, r)$. Then

$$\frac{1}{2\pi i} \oint_{\partial D(P, r)} \frac{f'(\zeta)}{f(\zeta)} d\zeta = \sum_{n=1}^p n_n - \sum_{k=1}^q m_k,$$

where n_1, n_2, \dots, n_p are the multiplicities of the zeros z_1, z_2, \dots, z_p of f in $D(P, r)$ and m_1, m_2, \dots, m_q are the orders of the poles w_1, w_2, \dots, w_q of f in $D(P, r)$.

associative law If a, b, c are complex numbers then

$$(a + b) + c = a + (b + c) \quad (\text{Associativity of Addition})$$

and

$$(a \cdot b) \cdot c = a \cdot (b \cdot c). \quad (\text{Associativity of Multiplication})$$

assumes the value β to order n A holomorphic function assumes the value β to order n at the point P if the function $f(z) - \beta$ vanishes to order n at P .

barrier Let $U \subseteq \mathbb{C}$ be an open set and $P \in \partial U$. We call a function $b : \overline{U} \rightarrow \mathbb{R}$ a *barrier* for U at P if

- (a) b is continuous;
- (b) b is subharmonic on U ;
- (c) $b|_{\partial U} \leq 0$;
- (d) $\{z \in \partial U : b(z) = 0\} = \{P\}$.

beta function If $\operatorname{Re} z > 0, \operatorname{Re} w > 0$, then the beta function of z and w is

$$B(z, w) = \int_0^1 t^{z-1} (1-t)^{w-1} dt.$$

Bieberbach conjecture This is the problem of showing that each coefficient a_n of the power series expansion of a Schlicht function satisfies $|a_n| \leq n$.

In addition, the Kőbe functions are the only ones for which equality holds.

biholomorphic mapping See *conformal mapping*.

Blaschke condition A sequence of complex numbers $\{a_n\}$ satisfying

$$\sum_{n=1}^{\infty} (1 - |a_n|) < \infty$$

is said to satisfy the Blaschke condition.

Blaschke factor This is a function of the form

$$B_a(z) = \frac{z - a}{1 - \bar{a}z}$$

for some complex constant a of modulus less than one. See also *Möbius transformation*.

Blaschke factorization If f is a bounded holomorphic function or, more generally, a Hardy space function on the unit disc then we may write

$$f(z) = z^m \cdot \left\{ \prod_{n=1}^{\infty} \frac{-\bar{a}_n}{|a_n|} B_{a_n}(z) \right\} \cdot F(z).$$

Here m is the order of the zero of f at $z = 0$, the points a_n are the zeros of f (counting multiplicities), and F is a nonvanishing Hardy space function.

Blaschke product If $\{a_n\}$ satisfies the Blaschke condition then the infinite product

$$\prod_{n=1}^{\infty} \frac{-\bar{a}_n}{|a_n|} B_{a_n}(z)$$

converges uniformly on compact subsets of the unit disc to define a holomorphic function B on $D(0, 1)$. The function B is called a Blaschke product.

Bohr-Mollerup theorem Suppose that $\phi : (0, \infty) \rightarrow (0, \infty)$ satisfies

- (a) $\log \phi(x)$ is convex;

$$(b) \phi(x+1) = x \cdot \phi(x), \quad \text{all } x > 0;$$

$$(c) \phi(1) = 1.$$

Then $\phi(x) \equiv \Gamma(x)$. Thus Γ is the only meromorphic function on \mathbb{C} satisfying the functional equation $z\Gamma(z) = \Gamma(z+1)$, $\Gamma(1) = 1$, and which is logarithmically convex on the positive real axis.

boundary maximum principle for harmonic functions Let $U \subseteq \mathbb{C}$ be a bounded domain. Let u be a continuous function on \overline{U} that is harmonic on U . Then the maximum value of u on \overline{U} (which must occur, since \overline{U} is closed and bounded—see [RUD1], [KRA2]) must occur on ∂U .

boundary maximum principle for holomorphic functions Let $U \subseteq \mathbb{C}$ be a bounded domain. Let f be a continuous function on \overline{U} that is holomorphic on U . Then the maximum value of $|f|$ on \overline{U} (which must occur, since \overline{U} is closed and bounded—see [RUD1], [KRA2]) must occur on ∂U .

boundary minimum principle for harmonic functions Let $U \subseteq \mathbb{C}$ be a bounded domain. Let u be a continuous function on \overline{U} that is harmonic on U . Then the minimum value of u on \overline{U} (which must occur, since \overline{U} is closed and bounded—see [RUD1], [KRA2]) must occur on ∂U .

boundary uniqueness for harmonic functions Let $U \subseteq \mathbb{C}$ be a bounded domain. Let u_1 and u_2 be continuous functions on \overline{U} which are harmonic on U . If $u_1 = u_2$ on ∂U then $u_1 = u_2$ on all of \overline{U} .

bounded on compact sets Let \mathcal{F} be a family of functions on an open set $U \subseteq \mathbb{C}$. We say that \mathcal{F} is *bounded on compact sets* if for each compact set $K \subseteq U$ there is a constant $M = M_K$ such that for all $f \in \mathcal{F}$ and all $z \in K$ we have

$$|f(z)| \leq M.$$

bounded holomorphic function A holomorphic function f on a domain U is said to be bounded if there is a positive constant M such that

$$|f(z)| \leq M$$

for all $z \in U$.

Carathéodory's theorem Let $\varphi : \Omega_1 \rightarrow \Omega_2$ be a conformal mapping. If $\partial\Omega_1, \partial\Omega_2$ are Jordan curves (simple, closed curves) then φ (resp. φ^{-1}) extends one-to-one and continuously to $\partial\Omega_1$ (resp. $\partial\Omega_2$).

Casorati-Weierstrass theorem Let f be holomorphic on a deleted neighborhood of P and supposed that f has an essential singularity at P . Then the set of values of f is dense in the complex plane.

Cauchy estimates If f is holomorphic on a region containing the closed disc $\overline{D}(P, r)$ and if $|f| \leq M$ on $\overline{D}(P, r)$, then

$$\left| \frac{\partial^k}{\partial z^k} f(P) \right| \leq \frac{M \cdot k!}{r^k}.$$

Cauchy-Goursat theorem Any function that has the complex derivative at each point of a domain U is in fact holomorphic. In particular, it is continuously differentiable and satisfies the Cauchy-Riemann equations.

Cauchy integral formula Let f be holomorphic on an open set U that contains the closed disc $\overline{D}(P, r)$. Let $\gamma(t) = P + re^{it}$. Then, for each $z \in D(P, r)$,

$$f(z) = \frac{1}{2\pi i} \oint_{\gamma} \frac{f(\zeta)}{\zeta - z} d\zeta.$$

The formula is also true for more general curves.

Cauchy integral formula for an annulus Let f be holomorphic on an annulus $\{z \in \mathbb{C} : r < |z - P| < R\}$. Let $r < s < S < R$. Then for each $z \in D(P, S) \setminus \overline{D}(P, s)$ we have

$$f(z) = \frac{1}{2\pi i} \oint_{|\zeta - P| = S} \frac{f(\zeta)}{\zeta - P} d\zeta - \frac{1}{2\pi i} \oint_{|\zeta - P| = s} \frac{f(\zeta)}{\zeta - P} d\zeta.$$

Cauchy integral theorem If f is holomorphic on a disc U and if $\gamma : [a, b] \rightarrow U$ is a closed curve then

$$\oint_{\gamma} f(z) dz = 0.$$

The formula is also true for more general curves.

Cauchy-Riemann equations If u and v are real-valued, continuously differentiable functions on the domain U then u and v are said to satisfy the Cauchy-Riemann equations on U if

$$\frac{\partial u}{\partial x} = \frac{\partial v}{\partial y} \quad \text{and} \quad \frac{\partial v}{\partial x} = -\frac{\partial u}{\partial y}.$$

Cauchy-Schwarz Inequality The statement that if z_1, \dots, z_n and w_1, \dots, w_n are complex numbers then

$$\left| \sum_{n=1}^n z_n w_n \right|^2 \leq \sum_{n=1}^n |z_n|^2 \sum_{n=1}^n |w_n|^2.$$

Cayley transform This is the function

$$f(z) = \frac{i - z}{i + z}$$

that conformally maps the upper half-plane to the unit disc.

classification of singularities in terms of Laurent series Let the holomorphic function f have an isolated singularity at P , and let

$$\sum_{n=-\infty}^{\infty} a_n (z - P)^n$$

be its Laurent expansion. Then

- If $a_n = 0$ for all $n < 0$ then f has a removable singularity at P .
- If, for some $k < 0$, $a_k \neq 0$ and $a_n = 0$ for $n < k$ then f has a pole of order k at P .
- If there are infinitely many nonzero a_n with negative index n then f has an essential singularity at P .

clockwise The direction of traversal of a curve γ such that the region interior to the curve is always on the right.

closed curve A curve $\gamma : [a, b] \rightarrow \mathbb{C}$ such that $\gamma(a) = \gamma(b)$.

closed disc of radius r and center P A disc in the plane having radius r and center P and *including* the boundary of the disc.

closed set A set E in the plane with the property that the complement of E is open.

commutative law If a, b, c are complex numbers then

$$a + b = b + a \quad (\text{Commutativity of Addition})$$

and

$$a \cdot b = b \cdot a \quad (\text{Commutativity of Multiplication})$$

compact A set $K \subseteq \mathbb{C}$ is compact if it is both closed and bounded.

complex derivative If f is a function on a domain U then the complex derivative of f at a point P in U is the limit

$$\lim_{z \rightarrow P} \frac{f(z) - f(P)}{z - P}.$$

complex differentiable A function f is differentiable on a domain U if it possesses the complex derivative at each point of U .

complex line integral Let U be a domain, g a continuous function on U , and $\gamma : [a, b] \rightarrow U$ a curve. The complex line integral of g along γ is

$$\oint_{\gamma} g(z) dz \equiv \int_a^b g(\gamma(t)) \cdot \frac{d\gamma}{dt}(t) dt.$$

complex numbers Any number of the form $x + iy$ with x and y real.

condition for the convergence of an infinite product of numbers If

$$\sum_{n=1}^{\infty} |a_n| < \infty$$

then both

$$\prod_{n=1}^{\infty} (1 + |a_n|)$$

and

$$\prod_{n=1}^{\infty} (1 + a_n)$$

converge.

condition for the uniform convergence of an infinite product of functions Let $U \subseteq \mathbb{C}$ be a domain and let f_n be holomorphic functions on U . Assume that

$$\sum_{n=1}^{\infty} |f_n|$$

converges uniformly on compact subsets of U . Then the sequence of partial products

$$F_N(z) \equiv \prod_{n=1}^N (1 + f_n(z))$$

converges uniformly on compact sets to a holomorphic limit $F(z)$. We write

$$F(z) = \prod_{n=1}^{\infty} (1 + f_n(z)).$$

conformal A function f on a domain U is conformal if it preserves angles and dilates equally in all directions. A holomorphic function is conformal, and conversely.

conformal mapping Let U, V be domains in \mathbb{C} . A function $f : U \rightarrow V$ that is holomorphic, one-to-one, and onto is called a conformal mapping or conformal map.

conformal self-map Let $U \subseteq \mathbb{C}$ be a domain. A function $f : U \rightarrow U$ that is holomorphic, one-to-one, and onto is called a conformal (or biholomorphic) self-map of U .

conjugate If $z = x + iy$ is a complex number then $\bar{z} = x - iy$ is its conjugate.

connected A set S in the plane is connected if there do not exist disjoint and nonempty open sets U and V such that $S = (S \cap U) \cup (S \cap V)$.

continuing a function element Finding additional function elements that are analytic continuations of the given function element.

continuous A function f with domain S is continuous at a point P in S if the limit of $f(x)$ as x approaches P is $f(P)$. An equivalent definition, coming from topology, is that f is continuous provide that whenever V is an open set in the range of f then $f^{-1}(V)$ is open in the domain of f .

continuously differentiable A function f with domain S is continuously differentiable if the first derivative(s) of f exist at every point of S and if each of those first derivative functions is continuous on S .

continuously differentiable, k times A function f with domain S such that all derivatives of f up to and including order k exist and each of those derivative functions is continuous on S .

convergence of a Laurent series The Laurent series

$$\sum_{n=-\infty}^{\infty} a_n(z - P)^n$$

is said to converge if each of the power series

$$\sum_{n=-\infty}^0 a_n(z - P)^n \quad \text{and} \quad \sum_1^{\infty} a_n(z - P)^n$$

converges.

convergence of an infinite product An infinite product

$$\prod_{n=1}^{\infty} (1 + a_n)$$

is said to *converge* if

- Only a finite number a_{n_1}, \dots, a_{n_k} of the a_n 's are equal to -1 ;
- If $N_0 > 0$ is so large that $a_n \neq -1$ for $n > N_0$, then

$$\lim_{N \rightarrow +\infty} \prod_{n=N_0+1}^N (1 + a_n)$$

exists and is nonzero.

convergence of a power series The power series

$$\sum_{n=0}^{\infty} a_n (z - P)^n$$

is said to converge at z if the partial sums $S_N(z)$ converge as a sequence of numbers.

converges uniformly See *uniform convergence*.

countable set A set S is countable if there is a one-to-one, onto function $f : S \rightarrow \mathbb{N}$.

countably infinite set See *countable set*.

counterclockwise The direction of traversal of a curve γ such that the region interior to the curve is always on the left.

counting function This is a function from classical number theory that aids in counting the prime numbers.

curve A continuous function $\gamma : [a, b] \rightarrow \mathbb{C}$.

deformability Let U be a domain. Let $\gamma : [a, b] \rightarrow U$ and $\mu : [a, b] \rightarrow U$ be curves in U . We say that γ is deformable to μ in U if there is a continuous function $H(s, t)$, $0 \leq s \leq 1$ such that $H(0, t) = \gamma(t)$, $H(1, t) = \mu(t)$, and $H(s, t) \in U$ for all (s, t) .

deleted neighborhood Let $P \in \mathbb{C}$. A set of the form $D(P, r) \setminus \{P\}$ is called a deleted neighborhood of P .

denumerable set A set that is either finite or countably infinite.

derivative with respect to z If f is a function on a domain U then the derivative of f with respect to z on U is

$$\frac{\partial f}{\partial z} = \frac{1}{2} \left(\frac{\partial}{\partial x} - i \frac{\partial}{\partial y} \right) f.$$

derivative with respect to \bar{z} If f is a function on a domain U then the derivative of f with respect to \bar{z} on U is

$$\frac{\partial f}{\partial \bar{z}} = \frac{1}{2} \left(\frac{\partial}{\partial x} + i \frac{\partial}{\partial y} \right) f.$$

differentiable See *complex differentiable*.

direct analytic continuation Let (f, U) and (g, V) be function elements. We say that (g, V) is a *direct analytic continuation* of (f, U) if $U \cap V \neq \emptyset$ and $f = g$ on $U \cap V$.

Dirichlet problem on the disc Given a continuous function f on $\partial D(0, 1)$, find a continuous function u on $\overline{D}(0, 1)$ whose restriction to $\partial D(0, 1)$ equals f .

Dirichlet problem on a general domain Let $U \subseteq \mathbb{C}$ be a domain. Let f be a continuous function on ∂U . Find a continuous function u on \bar{U} such that u agrees with f on ∂U .

disc of convergence A power series

$$\sum_{n=0}^{\infty} a_n (z - P)^n$$

converges on a disc $D(P, r)$, where

$$r = \frac{1}{\limsup_{n \rightarrow \infty} |a_n|^{1/n}}.$$

The disc $D(P, r)$ is the disc of convergence of the power series.

discrete set A set $S \subset \mathbb{C}$ is discrete if for each $s \in S$ there is an $\delta > 0$ such that $D(s, \delta) \cap S = \{s\}$. See also *isolated point*.

distributive law If a, b, c are complex numbers then the distributive laws are

$$a \cdot (b + c) = ab + ac$$

and

$$(b + c) \cdot a = ba + ca.$$

domain A set U in the plane that is both open and connected.

domain of a function The domain of a function f is the set of numbers or points to which f can be applied.

entire function A holomorphic function whose domain is all of \mathbb{C} .

equivalence class If \mathcal{R} is an equivalence relation on a set S then the sets $E_s \equiv \{s' \in S : (s, s') \in \mathcal{R}\}$ are called equivalence classes. See [KRA3] for more on equivalence classes and equivalence relations.

equivalence relation Let \mathcal{R} be a relation on a set S . We call \mathcal{R} an equivalence relation if \mathcal{R} is

- **reflexive:** For each $s \in S$, $(s, s) \in \mathcal{R}$;
- **symmetric:** If $s, s' \in S$ and $(s, s') \in \mathcal{R}$ then $(s', s) \in \mathcal{R}$;
- **transitive:** If $(s, s') \in \mathcal{R}$ and $(s', s'') \in \mathcal{R}$ then $(s, s'') \in \mathcal{R}$.

essential singularity If the point P is a singularity of the holomorphic function f , and if P is neither a removable singularity nor a pole, then P is called an essential singularity.

Euclidean algorithm The algorithm for long division in the theory of arithmetic.

Euler-Mascheroni constant The limit

$$\lim_{n \rightarrow \infty} \left\{ \left(1 + \frac{1}{2} + \frac{1}{3} + \cdots + \frac{1}{n} \right) - \log n \right\}$$

exists. The limit is a positive constant denoted by γ and called the Euler-Mascheroni constant.

Euler product formula For $\operatorname{Re} z > 1$, the infinite product $\prod_{p \in \mathcal{P}} (1 - 1/p^z)$ converges and

$$\frac{1}{\zeta(z)} = \prod_{p \in \mathcal{P}} \left(1 - \frac{1}{p^z} \right).$$

Here $\mathcal{P} = \{2, 3, 5, 7, 11, \dots\}$ is the set of prime numbers.

exponential, complex The function e^z .

extended line The real line (lying in the complex plane) with the point at infinity adjoined.

extended plane The complex plane with the point at infinity adjoined. See *stereographic projection*.

extended real numbers The real numbers with the points $+\infty$ and $-\infty$ adjoined.

field A number system that is closed under addition, multiplication, and division by nonzero numbers and in which these operations are commutative.

formula for the derivative Let $U \subseteq \mathbb{C}$ be an open set and let f be holomorphic on U . Then f is infinitely differentiable on U . Moreover, if $\overline{D}(P, r) \subseteq U$ and $z \in D(P, r)$ then

$$\left(\frac{\partial}{\partial z}\right)^k f(z) = \frac{k!}{2\pi i} \oint_{|\zeta-P|=r} \frac{f(\zeta)}{(\zeta-z)^{k+1}} d\zeta, \quad k = 0, 1, 2, \dots$$

functional equation for the zeta function This is the relation

$$\zeta(1-z) = 2\zeta(z)\Gamma(z) \cos\left(\frac{\pi}{2}z\right) \cdot (2\pi)^{-z},$$

which holds for all $z \in \mathbb{C}$.

function element An ordered pair (f, U) where U is an open disc and f is a holomorphic function defined on U .

Fundamental Theorem of Algebra The statement that every nonconstant polynomial has a root.

Fundamental Theorem of Calculus along Curves Let $U \subset \mathbb{C}$ be a domain and $\gamma = (\gamma_1, \gamma_2) : [a, b] \rightarrow U$ a C^1 curve. If $f \in C^1(U)$ then

$$f(\gamma(b)) - f(\gamma(a)) = \int_a^b \left(\frac{\partial f}{\partial x}(\gamma(t)) \cdot \frac{d\gamma_1}{dt} + \frac{\partial f}{\partial y}(\gamma(t)) \cdot \frac{d\gamma_2}{dt} \right) dt.$$

gamma function If $\operatorname{Re} z > 0$ then define

$$\Gamma(z) = \int_0^\infty t^{z-1} e^{-t} dt.$$

generalized circles and lines In the extended plane $\widehat{\mathbb{C}} = \mathbb{C} \cup \{\infty\}$, a generalized line (generalized circle) is an ordinary line union the point at infinity. Topologically, an extended line is a circle.

genus of an entire function The maximum of the rank of f and of the degree of the polynomial g in the exponential in the Weierstrass factorization.

global analytic function We have an equivalence relation by way of analytic continuation on the set of function elements. The equivalence classes ([KRA3, p. 53]) induced by this relation are called global analytic functions.

greatest lower bound See *infimum*.

Hankel contour The contour of integration C_ϵ used in the definition of the Hankel function.

Hankel function The function

$$H_\epsilon(z) = \int_{C_\epsilon} u(w) dw,$$

where $C_\epsilon = C_\epsilon(\delta)$ is the Hankel contour.

Hardy space If $0 < p < \infty$ then we define $H^p(D)$ to be the class of those functions holomorphic on the disc and satisfying the growth condition

$$\sup_{0 < r < 1} \left(\frac{1}{2\pi} \int_0^{2\pi} |f(re^{i\theta})|^p d\theta \right)^{1/p} < \infty.$$

In this circumstance we write $f \in H^p(D)$. It is convenient to use the notation $\|f\|_{H^p}$ to denote the displayed quantity.

We also let $H^\infty(D)$ denote the class of bounded holomorphic functions on D , and we let $\|f\|_{H^\infty}$ denote the supremum of f on D .

harmonic A function u on a domain U is said to be harmonic if $\Delta u = 0$ on U , that is, if u satisfies the Laplace equation.

harmonic conjugate If u is a real-valued harmonic function on a domain U then a real-valued harmonic function v on U is said to be conjugate to u if $h = u + iv$ is holomorphic.

Harnack inequality Let u be a nonnegative, harmonic function on a neighborhood of $\overline{D}(0, R)$. Then, for any $z \in D(0, R)$,

$$\frac{R - |z|}{R + |z|} \cdot u(0) \leq u(z) \leq \frac{R + |z|}{R - |z|} \cdot u(0).$$

More generally, let u be a nonnegative, harmonic function on a neighborhood of $\overline{D}(P, R)$. Then, for any $z \in D(P, R)$,

$$\frac{R - |z - P|}{R + |z - P|} \cdot u(P) \leq u(z) \leq \frac{R + |z - P|}{R - |z - P|} \cdot u(P).$$

Harnack principle Let $u_1 \leq u_2 \leq \dots$ be harmonic functions on a connected open set $U \subseteq \mathbb{C}$. Then either $u_n \rightarrow \infty$ uniformly on compact sets or there is a harmonic function u on U such that $u_n \rightarrow u$ uniformly on compact sets.

holomorphic A continuously differentiable function on a domain U is holomorphic if it satisfies the Cauchy-Riemann equations on U or (equivalently) if $\partial f / \partial \bar{z} = 0$ on U .

holomorphic function on a Riemann surface A function F is holomorphic on the Riemann surface \mathcal{R} if $F \circ \pi^{-1} : \pi(U) \rightarrow \mathbb{C}$ is holomorphic for each open set U in \mathcal{R} with π one-to-one on U .

homeomorphic Two open sets U and V in \mathbb{C} are *homeomorphic* if there is a one-to-one, onto, continuous function $f : U \rightarrow V$ with $f^{-1} : V \rightarrow U$ also continuous.

homeomorphism A *homeomorphism* of two sets $A, B \subseteq \mathbb{C}$ is a one-to-one, onto continuous mapping $F : A \rightarrow B$ with a continuous inverse.

homotopic See *deformability, homotopy*.

homotopy Let W be a domain in \mathbb{C} . Let $\gamma_0 : [0, 1] \rightarrow W$ and $\gamma_1 : [0, 1] \rightarrow W$ be curves. Assume that $\gamma_0(0) = \gamma_1(0) = P$ and that $\gamma_0(1) = \gamma_1(1) = Q$. We say that γ_0 and γ_1 are *homotopic in W* (with fixed endpoints) if there is a continuous function

$$H : [0, 1] \times [0, 1] \rightarrow W$$

such that

- 1) $H(0, t) = \gamma_0(t)$ for all $t \in [0, 1]$;
- 2) $H(1, t) = \gamma_1(t)$ for all $t \in [0, 1]$;
- 3) $H(s, 0) = P$ for all $s \in [0, 1]$;
- 4) $H(s, 1) = Q$ for all $s \in [0, 1]$.

Then H is called a *homotopy* (with fixed endpoints) of the curve γ_0 to the curve γ_1 . The two curves γ_0, γ_1 are said to be homotopic.

Hurwitz's theorem Suppose that $U \subseteq \mathbb{C}$ is a domain and that $\{f_n\}$ is a sequence of nowhere-vanishing holomorphic functions on U . If the sequence $\{f_n\}$ converges uniformly on compact subsets of U to a (necessarily holomorphic) limit function f_0 then either f_0 is nowhere-vanishing or $f_0 \equiv 0$.

image of a function The set of values taken by the function.

imaginary part If $z = x + iy$ is a complex number then its imaginary part is y .

imaginary part of a function f If $f = u + iv$ is a complex-valued function, with u and v real-valued functions, then v is its imaginary part.

index Let U be a domain and $\gamma : [0, 1] \rightarrow U$ a piecewise C^1 curve in U . Let $P \in U$ be a point that does not lie on γ . Then the index of γ with respect

to P is defined to be

$$\text{Ind}_\gamma(P) \equiv \frac{1}{2\pi i} \oint_\gamma \frac{1}{\zeta - P} d\zeta.$$

The index is always an integer.

infimum Let $S \subseteq \mathbb{R}$ be a set of numbers. We say that a number m is an infimum for S if $m \leq s$ for all $s \in S$ and there is no number greater than m that has the same property. Every set of real numbers that is bounded below has an infimum. The term “greatest lower bound” has the same meaning.

infinite product An expression of the form $\prod_{n=1}^{\infty} (1 + a_n)$.

integer A whole number, or one of $\cdots - 3, -2, -1, 0, 1, 2, 3, \dots$

integral representation of the beta function, alternate form For $z, w \notin \{0, -1, -2, \dots\}$,

$$B(z, w) = 2 \int_0^{\pi/2} (\sin \theta)^{2z-1} (\cos \theta)^{2w-1} d\theta.$$

irrational numbers Those numbers with nonterminating, nonrepeating decimal expansions.

isolated point A point P of a set $S \subseteq \mathbb{C}$ is said to be isolated if there is an $\delta > 0$ such that $D(P, \delta) \cap S = \{P\}$.

isolated singularity See *singularity*.

isolated singular point See *singularity*.

Jensen’s formula Let f be holomorphic on a neighborhood of $\overline{D}(0, r)$ and suppose that $f(0) \neq 0$. Let a_1, \dots, a_k be the zeros of f in $D(0, r)$, counted according to their multiplicities. Assume that f does not vanish on $\partial D(0, r)$. Then

$$\log |f(0)| + \sum_{n=1}^k \log \left| \frac{r}{a_n} \right| = \frac{1}{2\pi} \int_0^{2\pi} \log |f(re^{i\theta})| d\theta.$$

Jensen's inequality Let f as in Jensen's formula. Observing that $|r/a_n| \geq 1$ hence $\log |r/a_n| \geq 0$, we conclude that

$$\log |f(0)| \leq \frac{1}{2\pi} \int_0^{2\pi} \log |f(re^{i\theta})| d\theta.$$

Köbe function Let $0 \leq \theta < 2\pi$. The *Köbe function*

$$f_\theta(z) \equiv \frac{z}{(1 + e^{i\theta}z)^2}$$

is a schlicht function which satisfies $|a_n| = n$ for all n .

Köbe 1/4 theorem If f is schlicht then

$$f(D(0, 1)) \supseteq D(0, 1/4).$$

k times continuously differentiable A function f with domain S such that all derivatives of f up to and including order k exist and each of those derivatives is continuous on S .

Lambda function Define the function

$$\Lambda : \{n \in \mathbb{Z} : n > 0\} \rightarrow \mathbb{R}$$

by the condition

$$\Lambda(m) = \begin{cases} \log p & \text{if } m = p^k, p \in \mathcal{P}, 0 < k \in \mathbb{Z} \\ 0 & \text{otherwise.} \end{cases}$$

[Here \mathcal{P} is the collection of prime numbers.]

Laplace equation The partial differential equation

$$\Delta u = 0.$$

Laplace operator or Laplacian This is the partial differential operator

$$\Delta = \frac{\partial^2}{\partial x^2} + \frac{\partial^2}{\partial y^2}.$$

Laurent series A series of the form

$$\sum_{n=-\infty}^{\infty} a_n(z - P)^n.$$

See also *power series*.

Laurent series expansion about ∞ Fix a positive number R . Let f be holomorphic on a set of the form $\{z \in \mathbb{C} : |z| > R\}$. Define $G(z) = f(1/z)$ for $|z| < 1/R$. If the Laurent series expansion of G about 0 is

$$\sum_{n=-\infty}^{\infty} a_n z^n$$

then the Laurent series expansion of f about ∞ is

$$\sum_{n=-\infty}^{\infty} a_n z^{-n}.$$

least upper bound See *supremum*.

limit of the function f at the point P Let f be a function on a domain U . The complex number ℓ is the limit of the f at P if for each $\epsilon > 0$ there is a $\delta > 0$ such that whenever $z \in U$ and $0 < |z - P| < \delta$ then $|f(z) - \ell| < \epsilon$.

linear fractional transformation A function of the form

$$z \mapsto \frac{az + b}{cz + d},$$

for a, b, c, d complex constants with $ac - bd \neq 0$.

Liouville's theorem If f is an entire function that is bounded then f is constant.

locally A property is true locally if it is true on compact sets.

Lusin area integral Let $\Omega \subseteq \mathbb{C}$ be a domain and $\phi : \Omega \rightarrow \mathbb{C}$ a one-to-one holomorphic function. Then $\phi(\Omega)$ is a domain and

$$\text{area}(\phi(\Omega)) = \int_{\Omega} |\phi'(z)|^2 dx dy.$$

maximum principle for harmonic functions If u is a harmonic function on a domain U and if P in U is a local maximum for u then u is identically constant.

maximum principle for holomorphic functions If f is a holomorphic function on a domain U and if P in U is a local maximum for $|f|$ then f is identically constant.

maximum principle for subharmonic functions If u is subharmonic on U and if there is a $P \in U$ such that $u(P) \geq u(z)$ for all $z \in U$ then u is identically constant.

mean value property for harmonic functions Let u be harmonic on an open set containing the closed disc $\overline{D}(P, r)$. Then

$$u(P) = \frac{1}{2\pi} \int_0^{2\pi} u(P + re^{i\theta}) d\theta.$$

This identity also holds for holomorphic functions.

Mergelyan's theorem Let $K \subseteq \mathbb{C}$ be compact and suppose that $\widehat{\mathbb{C}} \setminus K$ has only finitely many connected components. If $f \in C(K)$ is holomorphic on $\overset{\circ}{K}$ and if $\epsilon > 0$ then there is a rational function $r(z)$ with poles in $\widehat{\mathbb{C}} \setminus K$ such that

$$\max_{z \in K} |f(z) - r(z)| < \epsilon.$$

Mergelyan's theorem for polynomials Let $K \subseteq \mathbb{C}$ be compact and assume that $\widehat{\mathbb{C}} \setminus K$ is connected. Let $f \in C(K)$ be holomorphic on $\overset{\circ}{K}$. Then for any $\epsilon > 0$ there is a holomorphic polynomial $p(z)$ such that

$$\max_{z \in K} |p(z) - f(z)| < \epsilon.$$

meromorphic at ∞ Fix a positive number R . Let f be holomorphic on a set of the form $\{z \in \mathbb{C} : |z| > R\}$. Define $G(z) = f(1/z)$ for $|z| < 1/R$. We say that f is meromorphic at ∞ provided that G is meromorphic in the usual sense on $\{z \in \mathbb{C} : |z| < 1/R\}$.

meromorphic function Let U be a domain and $\{P_n\}$ a discrete set in U . If f is holomorphic on $U \setminus \{P_n\}$ and f has a pole at each of the $\{P_n\}$ then f is said to be meromorphic on U .

minimum principle for harmonic functions If u is a harmonic function on a domain U and if P in U is a local minimum for u then u is identically constant.

minimum principle for holomorphic functions If f is a holomorphic function on a domain U , if f does not vanish on U , and if P in U is a local minimum for $|f|$ then f is identically constant.

Mittag-Leffler theorem Let $U \subseteq \mathbb{C}$ be any open set. Let $\alpha_1, \alpha_2, \dots$ be a finite or countably infinite set of *distinct elements of* U with no accumulation point in U . Suppose, for each n , that U_n is a neighborhood of α_n . Further assume, for each n , that m_n is a meromorphic function defined on U_n with a pole at α_n and no other poles. Then there exists a meromorphic m on U such that $m - m_n$ is holomorphic on U_n for every n .

Mittag-Leffler theorem, alternative formulation Let $U \subseteq \mathbb{C}$ be any open set. Let $\alpha_1, \alpha_2, \dots$ be a finite or countably infinite set of distinct elements of U , having no accumulation point in U . Let s_n be a sequence of

Laurent polynomials (or “principal parts”),

$$s_n(z) = \sum_{\ell=-p(n)}^{-1} a_\ell^n \cdot (z - \alpha_n)^\ell.$$

Then there is a meromorphic function on U whose principal part at each α_n is s_n .

Möbius transformation This is a function of the form

$$\phi_a(z) = \frac{z - a}{1 - \bar{a}z}$$

for a fixed complex constant a with modulus less than 1. Such a function ϕ_a is a conformal self-map of the unit disc.

modulus If $z = x + iy$ is a complex number then $|z| = \sqrt{x^2 + y^2}$ is its modulus.

monodromy theorem Let $W \subseteq \mathbb{C}$ be a domain. Let (f, U) be a function element, with $U \subseteq W$. Let P denote the center of the disc U . Assume that (f, U) admits unrestricted continuation in W . If γ_0, γ_1 are each curves that begin at P , terminate at some point Q , and are homotopic in W , then the analytic continuation of (f, U) to Q along γ_0 equals the analytic continuation of (f, U) to Q along γ_1 .

monogenic See *holomorphic*.

monotonicity of the Hardy space norm Let f be holomorphic on D . If $0 < r_1 < r_2 < 1$ then

$$\int_0^{2\pi} |f(r_1 e^{i\theta})|^p d\theta \leq \int_0^{2\pi} |f(r_2 e^{i\theta})|^p d\theta.$$

Montel's theorem Let $\mathcal{F} = \{f_\alpha\}_{\alpha \in A}$ be a family of holomorphic functions on an open set $U \subseteq \mathbb{C}$. If there is a constant $M > 0$ such that

$$|f(z)| \leq M, \text{ for all } z \in U, f \in \mathcal{F}$$

then there is a sequence $\{f_n\} \subseteq \mathcal{F}$ such that f_n converges normally on U to a limit (holomorphic) function f_0 .

Montel's theorem, second version Let $U \subseteq \mathbb{C}$ be an open set and let \mathcal{F} be a family of holomorphic functions on U that is bounded on compact sets. Then there is a sequence $\{f_n\} \subseteq \mathcal{F}$ that converges normally on U to a limit (necessarily holomorphic) function f_0 .

Morera's theorem Let f be a continuous function on a connected open set $U \subseteq \mathbb{C}$. If

$$\oint_{\gamma} f(z) dz = 0$$

for every simple closed curve γ in U then f is holomorphic on U . The result is true if it is only assumed that the integral is zero when γ is a rectangle, or when γ is a triangle.

multiple root Let f be either a polynomial or a holomorphic function on an open set U . Let k be a positive integer. If $P \in U$ and $f(P) = 0, f'(P) = 0, \dots, f^{(k-1)}(P) = 0$ then f is said to have a multiple root at P . The root is said to be of order k .

multiple singularities Let $U \subseteq \mathbb{C}$ be a domain and P_1, P_2, \dots be a discrete set in U . If f is holomorphic on $U \setminus \{P_n\}$ and has a singularity at each P_n then f is said to have multiple singularities in U .

multiplicity of a zero or root The number k in the definition of *multiple root*.

neighborhood of a point in a Riemann surface We define neighborhoods of a "point" (f, U) in \mathcal{R} by

$$\{(f_p, U_p) : p \in U \text{ and } (f_p, U_p) \text{ is a direct analytic continuation of } (f, U) \text{ to } p\}.$$

normal convergence of a sequence A sequence of functions g_n on a domain U is said to converge normally to a limit function g if the f_n converge

uniformly on compact subsets of U to g .

normal convergence of a series A series of functions $\sum_{n=1}^{\infty} g_n$ on a domain U is said to converge normally to a limit function g if the partial sums $S_N = \sum_{n=1}^N g_n$ converge uniformly on compact subsets of U to g .

normal family Let \mathcal{F} be a family of (holomorphic) functions with common domain U . We say that \mathcal{F} is a normal family if every sequence in \mathcal{F} has a subsequence that converges uniformly on compact subsets U , that is, *converges normally* on U . See *Montel's theorem*.

one-to-one A function $f : S \rightarrow T$ is said to be one-to-one if whenever $s_1 \neq s_2$ then $f(s_1) \neq f(s_2)$.

onto A function $f : S \rightarrow T$ is said to be onto if whenever $t \in T$ then there is an $s \in S$ such that $f(s) = t$.

open disc of radius r and center P A disc $D(P, r)$ in the plane having radius r and center P and *not* including the boundary of the disc.

open mapping A function $f : S \rightarrow T$ is said to be open if whenever $U \subseteq S$ is open then $f(U) \subseteq T$ is open.

open mapping theorem If $f : U \rightarrow \mathbb{C}$ is a holomorphic function on a domain U , then $f(U)$ will also be open.

open set A set U in the plane with the property that each point $P \in U$ has a disc $D(P, r)$ such that $D(P, r) \subseteq U$.

order of an entire function An entire function f is said to be of *finite order* if there exist numbers $a, r > 0$ such that

$$|f(z)| \leq \exp(|z|^a) \quad \text{for all } |z| > r.$$

The infimum of all numbers a for which such an inequality holds is called the *order* of f and is denoted by $\lambda = \lambda(f)$.

order of a pole See *pole*.

order of a root See *multiplicity of a root*.

Ostrowski-Hadamard gap theorem Let $0 < p_1 < p_2 < \dots$ be integers and suppose that there is a $\lambda > 1$ such that

$$\frac{p_{n+1}}{p_n} > \lambda \quad \text{for} \quad n = 1, 2, \dots$$

Suppose that, for some sequence of complex numbers $\{a_n\}$, the power series

$$f(z) = \sum_{n=1}^{\infty} a_n z^{p_n}$$

has radius of convergence 1. Then no point of ∂D is regular for f .

partial fractions A method for decomposing a rational function into a sum of simpler rational components. Useful in integration theory, as well as in various algebraic contexts. See [BLK] for details.

partial product For an infinite product $\prod_{n=1}^{\infty} (1 + a_n)$, the partial product is

$$P_N = \prod_{n=1}^N (1 + a_n).$$

partial sums of a power series If

$$\sum_{n=0}^{\infty} a_n (z - P)^n$$

is a power series then its partial sums are the expressions

$$S_N(z) \equiv \sum_{n=0}^N a_n (z - P)^n$$

for $N = 0, 1, 2, \dots$

path See *curve*.

path-connected Let $E \subseteq \mathbb{C}$ be a set. If, for any two points A and B in E there is a curve $\gamma : [0, 1] \rightarrow E$ such that $\gamma(0) = A$ and $\gamma(1) = B$ then we say that E is path-connected.

Picard's Great Theorem Let U be a region in the plane, $P \in U$, and suppose that f is holomorphic on $U \setminus \{P\}$ and has an essential singularity at P . If $\epsilon > 0$ then the restriction of f to $U \cap [D(P, \epsilon) \setminus \{P\}]$ assumes all complex values except possibly one.

Picard's Little Theorem If the range of an entire function f omits two points of \mathbb{C} then f is constant.

piecewise C^k A curve $\gamma : [a, b] \rightarrow \mathbb{C}$ is said to be piecewise C^k if

$$[a, b] = [a_0, a_1] \cup [a_1, a_2] \cup \cdots \cup [a_{m-1}, a_m]$$

with $a = a_0 < a_1 < \cdots < a_m = b$ and $\gamma|_{[a_{n-1}, a_n]}$ is C^k for $1 \leq n \leq m$.

π function For $x > 0$, this is the function

$$\pi(x) = \text{the number of prime numbers not exceeding } x.$$

point at ∞ A point which is adjoined to the complex plane to make it topologically a sphere.

Poisson integral formula Let $u : U \rightarrow \mathbb{R}$ be a harmonic function on a neighborhood of $\overline{D}(0, 1)$. Then, for any point $a \in D(0, 1)$,

$$u(a) = \frac{1}{2\pi} \int_0^{2\pi} u(e^{i\psi}) \cdot \frac{1 - |a|^2}{|a - e^{i\psi}|^2} d\psi.$$

Poisson kernel for the unit disc This is the function

$$\frac{1}{2\pi} \frac{1 - |a|^2}{|a - e^{i\psi}|^2}$$

that occurs in the Poisson integral formula.

polar form of a complex number A complex number z written in the form $z = re^{i\theta}$ with $r \geq 0$ and $\theta \in \mathbb{R}$. The number r is the modulus of z and θ is its argument.

polar representation of a complex number See *polar form*.

pole Let P be an isolated singularity of the holomorphic function f . If P is not a removable singularity for f but there exists a $k > 0$ such that $(z - P)^k \cdot f$ is a removable singularity, then P is called a pole of f . The least k for which this condition holds is called the order of the pole.

polynomial A polynomial is a function $p(z)$ (resp. $p(x)$) of the form

$$p(z) = a_0 + a_1z + \cdots + a_{k-1}z^{k-1} + a_kz^k,$$

(resp. $p(x) = a_0 + a_1x + \cdots + a_{k-1}x^{k-1} + a_kx^k$) where a_0, \dots, a_k are complex constants.

power series A series of the form

$$\sum_{n=0}^{\infty} a_n(z - P)^n.$$

More generally, the series can have any limits on the indices:

$$\sum_{n=m}^{\infty} a_n(z - P)^n \quad \text{or} \quad \sum_{n=m}^n a_n(z - P)^n.$$

prevertices The inverse images of the corners of the polygon under study with the Schwarz-Christoffel mapping.

prime number This is an integer (whole number) that has no integer divisors except 1 and itself. The first few positive prime numbers are 2, 3, 5, 7, 11, 13, 17, 19, 23. By convention, 1 is not prime.

prime number theorem This is the statement that

$$\lim_{x \rightarrow \infty} \frac{\pi(x)}{x/\log x} = 1.$$

principal branch Usually that branch of a holomorphic function that focuses on values of the argument $0 \leq \theta < 2\pi$. The precise definition of “principal branch” depends on the particular function being studied.

principle of persistence of functional relations If two holomorphic functions defined in a domain containing the real axis agree for real values of the argument then they agree at all points.

principal part Let f have a pole of order k at P . The negative power part

$$\sum_{n=-k}^{-1} a_n(z-P)^n$$

of the Laurent series of f about P is called the principal part of f at P .

range of a function Any set containing the image of the function.

rank of an entire function If f is an entire function and $\{a_n\}$ its zeros counting multiplicity, then the rank of f to be the least positive integer such that

$$\sum_{a_n \neq 0} |a_n|^{-(p+1)} < \infty.$$

We denote the rank of f by $p = p(f)$.

rational function A *rational* function is a quotient of polynomials.

rational number system Those numbers that are quotients of integers or whole numbers. These numbers have either terminating or repeating decimal expansions.

real analytic A function f of one or several real variables is called *real analytic* if it can locally be expressed as a convergent power series.

real number system Those numbers consisting of either terminating or nonterminating decimal expansions.

real part If $z = x + iy$ is a complex number then its real part is x .

real part of a function f If $f = u + iv$, with u, v real-valued functions, is a complex-valued function then u is its real part.

recursive identity for the gamma function If $\operatorname{Re} z > 0$ then

$$\Gamma(z + 1) = z \cdot \Gamma(z).$$

region See *domain*.

regular See *holomorphic*.

regular boundary point Let f be holomorphic on a domain U . A point P of ∂U is called *regular* if f extends to be a holomorphic function on an open set containing U and also the point P .

relation Let S be a set. A relation on S is a collection of some (but not necessarily all) of the ordered pairs (s, s') of elements of S . See also *equivalence relation*.

removable singularity Let P be an isolated singularity of the holomorphic function f . If f can be defined at P so as to be holomorphic in a neighborhood of P then P is called a removable singularity for f .

residue If f has Laurent series

$$\sum_{n=-\infty}^{\infty} a_n(z - P)^n$$

about P , then the number a_{-1} is called the residue of f at P . We denote the residue by $\text{Res}_f(P)$.

residue, formula for Let f have a pole of order k at P . Then the residue of f at P is given by

$$\text{Res}_f(P) = \frac{1}{(k-1)!} \left(\frac{\partial}{\partial z} \right)^{k-1} ((z-P)^k f(z)) \Big|_{z=P}.$$

residue theorem Let U be a domain and let the holomorphic function f have isolated singularities at $P_1, P_2, \dots, P_m \in U$. Let $\text{Res}_f(P_n)$ be the residue of f at P_n . Also let $\gamma : [0, 1] \rightarrow U \setminus \{P_1, P_2, \dots, P_m\}$ be a piecewise C^1 curve. Let $\text{Ind}_\gamma(P_n)$ be the winding number of γ about P_n . Then

$$\oint_\gamma f(z) dz = 2\pi i \sum_{n=1}^m \text{Res}_f(P_n) \cdot \text{Ind}_\gamma(P_n).$$

Riemann hypothesis The celebrated Riemann hypothesis is the conjecture that all the zeros of the zeta function ζ in the critical strip $\{z \in \mathbb{C} : 0 < \text{Re } z < 1\}$ actually lie on the line $\{z : \text{Re } z = 1/2\}$.

Riemann mapping theorem Let $U \subseteq \mathbb{C}$ be a simply connected domain, and assume that $U \neq \mathbb{C}$. Then there is a conformal mapping $\varphi : U \rightarrow D(0, 1)$.

Riemann removable singularities theorem If P is an isolated singularity of the holomorphic function f and if f is bounded in a deleted neighborhood of P then f has a removable singularity at P .

Riemann sphere See *extended plane*.

Riemann surface The idea of a Riemann surface is that one can visualize geometrically the behavior of function elements and their analytic continuation. A global analytic function is the set of all function elements obtained by analytic continuation along curves (from a base point $P \in \mathbb{C}$) of a function

element (f, U) at P . Such a set, which amounts to a collection of convergent power series at different points of the plane \mathbb{C} , can be given the structure of a surface, in the intuitive sense of that word.

right turn angle The oriented angle of turning when traversing the boundary of a polygon that is under study with the Schwarz-Christoffel mapping.

ring A number system that is closed under addition and multiplication. See also *field*.

root of a function or polynomial A value in the domain at which the function or polynomial vanishes. See also *zero*.

rotation A function $z \mapsto e^{i\alpha}z$ for some fixed real number α . We sometimes say that the function represents “rotation through an angle α .”

Rouché’s theorem Let f, g be holomorphic functions on a domain $U \subseteq \mathbb{C}$. Suppose that $\overline{D}(P, r) \subseteq U$ and that, for each $\zeta \in \partial D(P, r)$,

$$|f(\zeta) - g(\zeta)| < |f(\zeta)| + |g(\zeta)|. \quad (*)$$

Then the number of zeros of f inside $D(P, r)$ equals the number of zeros of g inside $D(P, r)$. The hypothesis $(*)$ is sometimes replaced in practice with

$$|f(\zeta) - g(\zeta)| < |g(\zeta)|$$

for $\zeta \in \partial D(P, r)$.

Runge’s theorem Let $K \subseteq \mathbb{C}$ be compact. Let f be holomorphic on a neighborhood of K . Let $\mathcal{P} \subseteq \widehat{\mathbb{C}} \setminus K$ contain one point from each connected component of $\widehat{\mathbb{C}} \setminus K$. Then for any $\epsilon > 0$ there is a rational function $r(z)$ with poles in \mathcal{P} such that

$$\max_{z \in K} |f(z) - r(z)| < \epsilon.$$

Runge’s theorem, corollary for polynomials Let $K \subseteq \mathbb{C}$ be compact and assume that $\widehat{\mathbb{C}} \setminus K$ is connected. Let f be holomorphic on a neighborhood of

K . Then for any $\epsilon > 0$ there is a holomorphic polynomial $p(z)$ such that

$$\max_K |p(z) - f(z)| < \epsilon.$$

Schlicht function A holomorphic function f on the unit disc D is called *schlicht* if

- f is one-to-one
- $f(0) = 0$
- $f'(0) = 1$.

In this circumstance we write $f \in \mathcal{S}$.

Schwarz-Christoffel mapping A conformal mapping from the upper half-plane to a polygon.

Schwarz-Christoffel parameter problem The problem of determining the prevertices of a Schwarz-Christoffel mapping.

Schwarz lemma Let f be holomorphic on the unit disc. Assume that

- $|f(z)| \leq 1$ for all z .
- $f(0) = 0$.

Then $|f(z)| \leq |z|$ and $|f'(0)| \leq 1$.

If either $|f(z)| = |z|$ for some $z \neq 0$ or if $|f'(0)| = 1$ then f is a rotation: $f(z) \equiv \alpha z$ for some complex constant α of unit modulus.

Schwarz-Pick lemma Let f be holomorphic on the unit disc. Assume that

- $|f(z)| \leq 1$ for all z .
- $f(a) = b$ for some $a, b \in D(0, 1)$.

Then

$$|f'(a)| \leq \frac{1 - |b|^2}{1 - |a|^2}.$$

Moreover, if $f(a_1) = b_1$ and $f(a_2) = b_2$ then

$$\left| \frac{b_2 - b_1}{1 - \bar{b}_1 b_2} \right| \leq \left| \frac{a_2 - a_1}{1 - \bar{a}_1 a_2} \right|.$$

There is a “uniqueness” result in the Schwarz-Pick Lemma. If either

$$|f'(a)| = \frac{1 - |b|^2}{1 - |a|^2} \quad \text{or} \quad \left| \frac{b_2 - b_1}{1 - \bar{b}_1 b_2} \right| = \left| \frac{a_2 - a_1}{1 - \bar{a}_1 a_2} \right|$$

then the function f is a conformal self-mapping (one-to-one, onto holomorphic function) of $D(0, 1)$ to itself.

Schwarz reflection principle for harmonic functions Let V be a connected open set in \mathbb{C} . Suppose that $V \cap (\text{real axis}) = \{x \in \mathbb{R} : a < x < b\}$. Set $U = \{z \in V : \text{Im } z > 0\}$. Assume $v : U \rightarrow \mathbb{R}$ is harmonic and that, for each $\zeta \in V \cap (\text{real axis})$,

$$\lim_{U \ni z \rightarrow \zeta} v(z) = 0.$$

Set $\tilde{U} = \{\bar{z} : z \in U\}$. Define

$$\hat{v}(z) = \begin{cases} v(z) & \text{if } z \in U \\ 0 & \text{if } z \in V \cap (\text{real axis}) \\ -v(\bar{z}) & \text{if } z \in \tilde{U}. \end{cases}$$

Then \hat{v} is harmonic on $U \cup \tilde{U} \cup \{x \in \mathbb{R} : a < x < b\}$.

Schwarz reflection principle for holomorphic functions Let V be a connected open set in \mathbb{C} such that $V \cap (\text{the real axis}) = \{x \in \mathbb{R} : a < x < b\}$ for some $a, b \in \mathbb{R}$. Set $U = \{z \in V : \text{Im } z > 0\}$. Suppose that $F : U \rightarrow \mathbb{C}$ is holomorphic and that

$$\lim_{U \ni z \rightarrow x} \text{Im } F(z) = 0$$

for each $x \in \mathbb{R}$ with $a < x < b$. Define $\hat{U} = \{z \in \mathbb{C} : \bar{z} \in U\}$. Then there is a holomorphic function G on $U \cup \hat{U} \cup \{x \in \mathbb{R} : a < x < b\}$ such that $G|_U = F$.

In fact $\phi(x) \equiv \lim_{U \ni z \rightarrow x} \operatorname{Re} F(z)$ exists for each $x = x + i0 \in (a, b)$ and

$$G(z) = \begin{cases} F(z) & \text{if } z \in U \\ \phi(x) + i0 & \text{if } z \in \{x \in \mathbb{R} : a < x < b\} \\ \overline{F(\bar{z})} & \text{if } z \in \widehat{U}. \end{cases}$$

simple closed curve A curve $\gamma : [a, b] \rightarrow \mathbb{C}$ such that $\gamma(a) = \gamma(b)$ but the curve crosses itself nowhere else.

simple root Let f be either a polynomial or a holomorphic function on an open set U . If $f(P) = 0$ but $f'(P) \neq 0$ then f is said to have a simple root at P . See also *multiple root*.

simply connected A domain U in the plane is simply connected if one of the following three equivalent conditions holds: it has no holes, or if its complement has only one connected component, or if each closed curve in U is homotopic to zero.

singularity Let f be a holomorphic function on $D(P, r) \setminus \{P\}$ (that is, on the disc minus its center). Then the point P is said to be a singularity of f .

singularity at ∞ Fix a positive number R . Let f be holomorphic on the set $\{z \in \mathbb{C} : |z| > R\}$. Define $G(z) = f(1/z)$ for $|z| < 1/R$. Then

- If G has a removable singularity at 0 then we say that f has a removable singularity at ∞ .
- If G has a pole at 0 then we say that f has a pole at ∞ .
- If G has an essential singularity at 0 then we say that f has an essential singularity at ∞ .

small circle mean value property A continuous function h on a domain $U \subseteq \mathbb{C}$ is said to have this property if, for each point $P \in U$, there is a number $\epsilon_P > 0$ such that $\overline{D}(P, \epsilon_P) \subseteq U$ and, for every $0 < \epsilon < \epsilon_P$,

$$h(P) = \frac{1}{2\pi} \int_0^{2\pi} h(P + \epsilon e^{i\theta}) d\theta.$$

A function with the small circle mean value property on U must be harmonic on U .

smooth curve A curve $\gamma : [a, b] \rightarrow \mathbb{C}$ is smooth if γ is a C^k function (where k suits the problem at hand, and may be ∞) and γ' never vanishes.

smooth deformability Deformability in which the function $H(s, t)$ is smooth. See *deformability*.

solution of the Dirichlet problem on the disc Let f be a continuous function on $\partial D(0, 1)$. Define

$$u(z) = \begin{cases} \frac{1}{2\pi} \int_0^{2\pi} f(e^{i\psi}) \cdot \frac{1 - |z|^2}{|z - e^{i\psi}|^2} d\psi & \text{if } z \in D(0, 1) \\ f(z) & \text{if } z \in \partial D(0, 1). \end{cases}$$

Then u is continuous on $\overline{D}(0, 1)$ and harmonic on $D(0, 1)$.

special function These are particular functions that arise in theoretical physics, partial differential equations, and mathematical analysis. See *gamma function*, *beta function*.

stereographic projection A geometric method for mapping the plane to a sphere.

subharmonic Let $U \subseteq \mathbb{C}$ be an open set and f a real-valued continuous function on U . Suppose that for each $\overline{D}(P, r) \subseteq U$ and every real-valued harmonic function h defined on a neighborhood of $\overline{D}(P, r)$ which satisfies $f \leq h$ on $\partial D(P, r)$, it holds that $f \leq h$ on $D(P, r)$. Then f is said to be subharmonic on U .

submean value property Let $f : U \rightarrow \mathbb{R}$ be continuous. Then f satisfies the submean value property if, for each $\overline{D}(P, r) \subseteq U$,

$$f(P) \leq \frac{1}{2\pi} \int_0^{2\pi} f(P + re^{i\theta}) d\theta.$$

supremum Let $S \subseteq \mathbb{R}$ be a set of numbers. We say that a number M is a supremum for S if $s \leq M$ for all $s \in S$ and there is no number less than M that has the same property. Every set of real numbers that is bounded above has a supremum. The term “least upper bound” has the same meaning.

topology A mathematical structure specifying open and closed sets and a notion of convergence.

triangle inequality The statement that if z, w are complex numbers then

$$|z + w| \leq |z| + |w|.$$

uniform convergence for a sequence Let f_n be a sequence of functions on a set S . The f_n are said to converge uniformly to a function g on S if for each $\epsilon > 0$ there is a $N > 0$ such that if $n > N$ then $|f_n(s) - g(s)| < \epsilon$ for all $s \in S$. In other words, $f_n(s)$ converges to $g(s)$ at the same rate at each point of S .

uniform convergence for a series The series

$$\sum_{n=1}^{\infty} f_n(z)$$

on a set S is said to converge uniformly to a limit function $F(z)$ if its sequence of partial sums converges uniformly to F . Equivalently, the series converges uniformly to F if for each $\epsilon > 0$ there is a number $N > 0$ such that if $n > N$ then

$$\left| \sum_{n=1}^n f_n(z) - F(z) \right| < \epsilon$$

for all $z \in S$.

uniform convergence on compact subsets for a sequence Let f_n be a sequence of functions on a domain U . The f_n are said to converge uniformly on compact subsets of U to a function g on U if, for each compact $K \subseteq U$ and

for each $\epsilon > 0$, there is a $N > 0$ such that if $n > N$ then $|f_n(k) - g(k)| < \epsilon$ for all $k \in K$. In other words, $f_n(k)$ converges to $g(k)$ at the same rate at each point of K .

uniform convergence on compact subsets for a series The series

$$\sum_{n=1}^{\infty} f_n(z)$$

on a domain U is said to be uniformly convergent on compact sets to a limit function $F(z)$ if, for each $\epsilon > 0$ and each compact $K \subseteq U$, there is an $N > 0$ such that if $n > N$ then

$$\left| \sum_{n=1}^N f_n(z) - F(z) \right| < \epsilon$$

for every $z \in K$.

uniformly Cauchy for a sequence Let g_n be a sequence of functions on a domain U . The sequence is uniformly Cauchy if, for each $\epsilon > 0$, there is an $N > 0$ such that for all $n, k > N$ and all $z \in U$ we have $|g_n(z) - g_k(z)| < \epsilon$.

uniformly Cauchy for a series Let $\sum_{n=1}^{\infty} g_n$ be a series of functions on a domain U . The series is uniformly Cauchy if, for each $\epsilon > 0$, there is an $N > 0$ such that: for all $L \geq M > N$ and all $z \in U$ we have $|\sum_{n=M}^L g_n(z)| < \epsilon$.

uniformly Cauchy on compact subsets for a sequence Let g_n be a sequence of functions on a domain U . The sequence is uniformly Cauchy on compact subsets of U if, for each K compact in U and each $\epsilon > 0$, there is an $N > 0$ such that for all $\ell, m > N$ and all $k \in K$ we have $|g_\ell(k) - g_m(k)| < \epsilon$.

uniformly Cauchy on compact subsets for a series Let $\sum_{n=1}^{\infty} g_n$ be a series of functions on a domain U . The series is uniformly Cauchy on compact subsets if, for each K compact in U and each $\epsilon > 0$, there is an $N > 0$ such that for all $L \geq M > N$ and all $k \in K$ we have $|\sum_{n=M}^L g_n(k)| < \epsilon$.

uniqueness of analytic continuation Let f and g be holomorphic functions on a domain U . If there is a disc $D(P, r) \subseteq U$ such that f and g agree

on $D(P, r)$ then f and g agree on all of U . More generally, if f and g agree on a set with an accumulation point in U then they agree at all points of U .

unrestricted continuation Let W be a domain and let (f, U) be a function element in W . We say (f, U) admits *unrestricted continuation* in W if there is an analytic continuation (f_t, U_t) of (f, U) along every curve γ that begins at P and lies in W .

value of an infinite product If $\prod_{n=1}^{\infty} (1 + a_n)$ converges, then we define its value to be

$$\left[\prod_{n=1}^{N_0} (1 + a_n) \right] \cdot \lim_{N \rightarrow +\infty} \prod_{N_0+1}^N (1 + a_n).$$

See *convergence of an infinite product*.

vanishing of an infinite product of functions The function f defined on a domain U by the infinite product

$$f(z) = \prod_{n=1}^{\infty} (1 + f_n(z))$$

vanishes at a point $z_0 \in U$ if and only if $f_n(z_0) = -1$ for some n . The multiplicity of the zero at z_0 is the sum of the multiplicities of the zeros of the functions $1 + f_n$ at z_0 .

Weierstrass factor These are the functions

$$E_0(z) = 1 - z$$

and, for $1 \leq p \in \mathbb{Z}$,

$$E_p(z) = (1 - z) \exp \left(z + \frac{z^2}{2} + \cdots + \frac{z^p}{p} \right).$$

Weierstrass factors are used in the factorization of entire functions. See *Weierstrass factorization theorem*.

Weierstrass factorization theorem Let f be an entire function. Suppose that f vanishes to order m at 0, $m \geq 0$. Let $\{a_n\}$ be the other zeros of f , listed with multiplicities. Then there is an entire function g such that

$$f(z) = z^m \cdot e^{g(z)} \prod_{n=1}^{\infty} E_{n-1} \left(\frac{z}{a_n} \right).$$

Here, for each n , E_n is a Weierstrass factor.

Weierstrass (canonical) product Let $\{a_n\}_{n=1}^{\infty}$ be a sequence of nonzero complex numbers with no accumulation point in the complex plane (note, however, that the a_n 's need not be distinct). If $\{p_n\}$ are positive integers that satisfy

$$\sum_{n=1}^{\infty} \left(\frac{r}{|a_n|} \right)^{p_n+1} < \infty$$

for every $r > 0$ then the infinite product

$$\prod_{n=1}^{\infty} E_{p_n} \left(\frac{z}{a_n} \right)$$

(called a Weierstrass product) converges uniformly on compact subsets of \mathbb{C} to an entire function F . The zeros of F are precisely the points $\{a_n\}$, counted with multiplicity.

Weierstrass theorem Let $U \subseteq \mathbb{C}$ be any open set. Let a_1, a_2, \dots be a finite or infinite sequence in U (possibly with repetitions) which has no accumulation point in U . Then there exists a holomorphic function f on U whose zero set is precisely $\{a_n\}$.

whole number See *integer*.

winding number See *index*.

zero If f is a polynomial or a holomorphic function on an open set U then $P \in U$ is a zero of f if $f(P) = 0$. See *root of a function or polynomial*.

zero set If f is a polynomial or a holomorphic function on an open set U then the zero set of f is $\{z \in U : f(z) = 0\}$.

zeta function For $\operatorname{Re} z > 1$, define

$$\zeta(z) = \sum_{n=1}^{\infty} \frac{1}{n^z} = \sum_{n=1}^{\infty} e^{-z \log n}.$$

List of Notation

Notation	Meaning	Section
\mathbb{R}	real number system	1.1.1
\mathbb{R}^2	Cartesian plane	1.1.1
\mathbb{C}	complex number system	1.1.2
z, w, ζ	complex numbers	1.1.2
$z = x + iy$	complex numbers	1.1.2
$w = u + iv$	complex numbers	1.1.2
$\zeta = \xi + i\eta$	complex numbers	1.1.2
$\operatorname{Re} z$	real part of z	1.1.2
$\operatorname{Im} z$	imaginary part of z	1.1.2
\bar{z}	conjugate of z	1.1.2
$ z $	modulus of z	1.2.1
$D(P, r)$	open disc	1.2.2
$\overline{D}(P, r)$	closed disc	1.2.2
D	open unit disc	1.2.2
\overline{D}	closed unit disc	1.2.2
$A \setminus B$	the complement of B in A	1.1.5
e^z	complex exponential	1.3.1
$!$	factorial	1.3.1
$\cos z$	$\frac{e^{iz} + e^{-iz}}{2}$	1.3.1
$\sin z$	$\frac{e^{iz} - e^{-iz}}{2i}$	1.3.1
$\arg z$	argument of z	1.3.5
C^k	k times continuously differentiable	2.1.1, 2.3.3
$f = u + iv$	real and imaginary parts of f	2.1.2

Notation	Meaning	Section
$\operatorname{Re} f$	real part of the function f	2.1.2
$\operatorname{Im} f$	imaginary part of the function f	2.1.2
$\partial f / \partial z$	derivative with respect to z	2.1.3
$\partial f / \partial \bar{z}$	derivative with respect to \bar{z}	2.1.3
$\lim_{z \rightarrow P} f(z)$	limit of f at the point P	2.1.5
df/dz	complex derivative	2.1.5
$f'(z)$	complex derivative	2.1.5
Δ	the Laplace operator	2.1.6, 2.2.1, 8.2.1
γ	a curve	2.3.1
$\gamma _{[c,d]}$	restriction of γ to $[c, d]$	2.3.2
$\oint_{\gamma} g(z) dz$	complex line integral of g along γ	2.3.6
$S_N(z)$	partial sum of a power series	4.1.6
$\sum_{j=0}^{\infty} a_j(z - P)^j$	complex power series	4.1.6
$\operatorname{Res}_f(P)$	residue of f at P	5.4.3
$\operatorname{Ind}_{\gamma}(P)$	index of γ with respect to P	5.4.4
$\widehat{\mathbb{C}}$	the extended complex plane	7.3.2, 7.3.3
$\mathbb{C} \cup \{\infty\}$	the extended complex plane	7.3.1
$L \cup \{\infty\}$	generalized circle	7.3.7
$\mathbb{R} \cup \{\infty\}$	extended real line	7.3.7
θ_n	right-turn angle	8.4.1
$\hat{f}(n)$	Fourier coefficient of f	10.1.1
$Sf(t)$	Fourier series of f	10.1.1

Notation	Meaning	Section
$S_N f(t)$	partial sum of Fourier series of f	10.1.1
$\widehat{f}(\xi)$	Fourier transform of f	10.2.1
$\underset{g}{\vee}$	inverse Fourier transform of g	10.2.1
$F(s)$	Laplace transform of f	10.3.1
$\mathcal{L}(f)$	Laplace transform of f	10.3.1
$A(z)$	z -transform of $\{a_n\}$	10.4.1

A Guide to the Literature

Complex analysis is an old subject, and the associated literature is large. Here we give the reader a representative sampling of some of the resources that are available. Of course no list of this kind can be complete.

Traditional Texts

- L. V. Ahlfors, *Complex Analysis*, 2nd ed., McGraw-Hill, New York, 1966.
- L. V. Ahlfors, *Conformal Invariants*, McGraw-Hill, 1973.
- C. Carathéodory, *Theory of Functions of a Complex Variable*, Chelsea, New York, 1954.
- H. P. Cartan, *Elementary Theory of Analytic Functions of One and Several Complex Variables*, Addison-Wesley, Reading, 1963.
- E. T. Copson, *An Introduction to the Theory of Functions of One Complex Variable*, The Clarendon Press, Oxford, 1972.
- R. Courant, *The Theory of Functions of a Complex Variable*, New York University, New York, 1949.
- P. Franklin, *Functions of Complex Variables*, Prentice-Hall, Englewood Cliffs, 1959.
- W. H. Fuchs, *Topics in the Theory of Functions of One Complex Variable*, Van Nostrand, Princeton, 1967.

- B. A. Fuks, *Functions of a Complex Variable and Some of Their Applications*, Addison-Wesley, Reading, 1961.
- G. M. Goluzin, *Geometric Theory of Functions of a Complex Variable*, American Mathematical Society, Providence, 1969.
- K. Knopp, *Theory of Functions*, Dover, New York, 1945-1947.
- Z. Nehari, *Introduction to Complex Analysis*, Allyn & Bacon, Boston, 1961.
- R. Nevanlinna, *Introduction to Complex Analysis*, Chelsea, New York, 1982.
- W. F. Osgood, *Functions of a Complex Variable*, G. E. Stechert, New York, 1942.
- G. Polya and G. Latta, *Complex Variables*, John Wiley & Sons, New York, 1974.
- n. Pierpont, *Functions of a Complex Variable*, Ginn & Co., Boston, 1912.
- S. Saks and A. Zygmund, *Analytic Functions*, Nakl. Polskiego Tow. Matematycznego, Warsaw, 1952.
- G. Sansone, *Lectures on the Theory of Functions of a Complex Variable*, P. Noordhoff, Groningen, 1960.
- V. I. Smirnov and N. A. Lebedev, *Functions of a Complex Variable; Constructive Theory*, MIT Press, Cambridge, 1969.

Modern Texts

- A. Beardon, *Complex Analysis: The Argument Principle in Analysis and Topology*, John Wiley & Sons, New York, 1979.
- C. Berenstein and R. Gay, *Complex Variables: An Introduction*, Springer, New York, 1991.
- R. P. Boas, *An Invitation to Complex Analysis*, Random House, New York, 1987.

- R. Burckel, *Introduction to Classical Complex Analysis*, Academic Press, New York, 1979.
- n. B. Conway, *Functions of One Complex Variable*, 2nd ed., Springer-Verlag, New York, 1979.
- n. Duncan, *The Elements of Complex Analysis*, John Wiley & Sons, New York, 1969.
- S. D. Fisher, *Complex Variables*, 2nd ed., Brooks/Cole, Pacific Grove, 1990.
- A. R. Forsyth, *Theory of Functions of a Complex Variable*, 3rd ed., Dover, New York, 1965.
- A. O. Gel'fond, *Residues and their Applications*, Mir Publishers, Moscow, 1971.
- R. E. Greene and S. G. Krantz, *Function Theory of One Complex Variable*, John Wiley and Sons, New York, 1997.
- M. Heins, *Complex Function Theory*, Academic Press, New York, 1969.
- E. Hille, *Analytic Function Theory*, 2nd ed., Chelsea, New York, 1973.
- W. Kaplan, *A First Course in Functions of a Complex Variable*, Addison-Wesley, Cambridge, 1953.
- S. G. Krantz, *Complex Analysis: The Geometric Viewpoint*, Mathematical Association of America, Washington, D.C., 1990.
- S. Lang, *Complex Analysis*, 3rd ed., Springer-Verlag, New York, 1993.
- N. Levinson and R. M. Redheffer, *Complex Variables*, Holden-Day, San Francisco, 1970.
- A. I. Markushevich, *Theory of Functions of a Complex Variable*, Prentice-Hall, Englewood Cliffs, 1965.
- Jerrold Marsden, *Basic Complex Analysis*, Freeman, San Francisco, 1973.

- G. Mikhailovich, *Geometric Theory of Functions of a Complex Variable*, American Mathematical Society, Providence, 1969.
- R. Narasimhan, *Complex Analysis in One Variable*, Birkhäuser, Boston, 1985.
- T. Needham, *Visual Complex Analysis*, Oxford University Press, New York, 1997.
- n. Noguchi, *Introduction to Complex Analysis*, American Mathematical Society, Providence, 1999.
- B. Palka, *An Introduction to Complex Function Theory*, Springer, New York, 1991.
- R. Remmert, *Theory of Complex Functions*, Springer-Verlag, New York, 1991.
- W. Rudin, *Real and Complex Analysis*, McGraw-Hill, New York, 1966.
- B. V. Shabat, *Introduction to Complex Analysis*, American Mathematical Society, Providence, 1992.
- M. R. Spiegel, *Schaum's Outline of the Theory and Problems of Complex Variables*, McGraw-Hill, New York, 1964.

Applied Texts

- M. Abramowitz and I. A. Stegun, *Handbook of Mathematical Functions*, Dover, New York, 1965.
- n. W. Brown and R. V. Churchill, *Complex Variables and Applications*, 6th ed., McGraw-Hill, New York, 1996.
- G. F. Carrier, M. Crook, and C. E. Pearson, *Functions of a Complex Variable: Theory and Technique*, McGraw-Hill, New York, 1966.
- W. Derrick, *Complex Analysis and Applications*, 2nd ed., Wadsworth, Belmont, 1984.
- A. Erdelyi, *The Bateman Manuscript Project*, McGraw-Hill, New York, 1954.

- P. Henrici, *Applied and Computational Complex Analysis*, John Wiley & Sons, New York, 1974–1986.
- A. Kyrala, *Applied Functions of a Complex Variable*, John Wiley and Sons, 1972.
- W. R. Le Page, *Complex Variables and the Laplace Transform for Engineers*, McGraw-Hill, New York, 1961.
- E. B. Saff and E. D. Snider, *Fundamentals of Complex Analysis for Mathematics, Science, and Engineering*, 2nd ed., Prentice-Hall, Englewood Cliffs, 1993.
- D. Zwillinger, et al, *CRC Standard Mathematical Tables and Formulas*, CRC Press, Boca Raton, 1996.

Bibliography

- [**AHL**] L. V. Ahlfors, *Complex Analysis*, 3rd ed., McGraw-Hill, New York, 1971.
- [**BLK**] B. Blank and S. G. Krantz, *Calculus*, Key Curriculum Press, Emeryville, CA, 2005.
- [**BRC**] W. Brown and R. V. Churchill, *Complex Variables and Applications*, 6th ed., McGraw-Hill, New York, 1991.
- [**CCP**] Carrier, G., Crook, M., and Pearson, C., *Functions of a Complex Variable: Theory and Technique*, McGraw-Hill, New York, 1966.
- [**COH**] R. Courant and D. Hilbert, *Methods of Mathematical Physics*, Wiley-Interscience, New York, 1953.
- [**DER**] W. Derrick, *Introductory Complex Analysis and Applications*, Academic Press, New York, 1972.
- [**FAK**] H. Farkas and I. Kra, *Riemann Surfaces*, Springer-Verlag, New York, 1971.
- [**FIF**] S. D. Fisher and John Franks, The fixed points of an analytic self-mapping, *Proc. AMS*, 99 (1987), 76–79.
- [**GRK**] R. E. Greene and S. G. Krantz, *Function Theory of One Complex Variable*, 2nd ed., American Mathematical Society, Providence, RI, 2002.
- [**HAL**] Hanselman, D. and Littlefield, B., *The Student Edition of MATLAB*, Prentice-Hall, Upper Saddle River, NJ, 1997.

- [HEN] P. Henrici, *Applied and Computational Complex Analysis*, John Wiley & Sons, New York, 1974–1981.
- [HES] Z. He and O. Schramm, Koebe uniformization and circle packing, *Ann. of Math.* 137 (1993), 361–401.
- [HER] I. Herstein, *Topics in Algebra*, Xerox, Lexington, 1975.
- [HOR] L. Hörmander, *Notions of Convexity*, Birkhäuser, Boston, MA, 1994.
- [HUN] T. Hungerford, *Abstract Algebra: An Introduction*, 2nd ed., Brooks Cole, Pacific Grove, CA, 1996.
- [KOB] Kober, H., *Dictionary of Conformal Representations*, 2nd ed., Dover Publications, New York, 1957.
- [KRA1] S. G. Krantz, *A Panorama of Harmonic Analysis*, Mathematical Association of America, Washington, D.C., 1991.
- [KRA2] S. G. Krantz, *Real Analysis and Foundations*, CRC Press, Boca Raton, FL, 2004.
- [KRA3] S. G. Krantz, *Complex Analysis: The Geometric Viewpoint*, 2nd ed., Mathematical Association of America, Washington, D.C., 2004.
- [KRA4] S. G. Krantz, *Cornerstones of Geometric Function Theory: Explorations in Complex Analysis*, Birkhäuser Publishing, Boston, MA, 2005.
- [KRA5] S. G. Krantz, *Partial Differential Equations and Complex Analysis*, CRC Press, Boca Raton, FL, 1992.
- [KRP] S. G. Krantz and H. R. Parks, *A Primer of Real Analytic Functions*, 2nd ed., Birkhäuser, Boston, MA, 2002.
- [KYT] P. Kythe, *Computational Conformal Mapping*, Birkhäuser, Boston, MA, 1998.
- [LES] K. Leschinger, Über fixpunkte holomorpher Automorphismen, *Manuscripta Math.*, 25 (1978), 391–396.
- [LOG] N. D. Logan, *Applied Mathematics*, 2nd ed., John Wiley and Sons, New York, 1997.

- [MAS] B. Maskit, The conformal group of a plane domain, *Amer. J. Math.*, 90 (1968), 718–722.
- [MAT] The Math Works, *MATLAB: The Language of Technical Computing*, The Math Works, Natick, MA, 1997.
- [MOC] Moler, C. and Costa, P., *MATLAB Symbolic Math Toolbox*, The Math Works, Inc., Natick, MA, 1997.
- [NEH] Nehari, Z., *Conformal Mapping*, Dover Publications, New York, 1952.
- [PRA] R. Pratrap, *Getting Started with MatLab*, Oxford University Press, Oxford, 1999.
- [RUD1] W. Rudin, *Principles of Mathematical Analysis*, 3rd ed., McGraw-Hill, New York, 1976.
- [RUD2] W. Rudin, *Real and Complex Analysis*, McGraw-Hill, New York, 1966.
- [SASN] E. B. Saff and E. D. Snider, *Fundamentals of Complex Analysis for Mathematics, Science, and Engineering*, 2nd ed., Prentice-Hall, Englewood Cliffs, 1993.
- [SIK] G. B. Simmons and S. G. Krantz, *Differential Equations: Theory, Technique, and Practice*, McGraw-Hill, New York, 2006.
- [STA] R. Stanley, *Enumerative Combinatorics*, Wadsworth Publishing, Belmont, CA, 1986.
- [ZWI] Zwillinger, D., et al., *CRC Standard Mathematical Tables and Formulae*, 30th ed., CRC Press, Boca Raton, FL, 1996.

Index

- accumulation point, 108
- algorithm for calculating Laurent coefficients, 131
- alternative formulations of mean value property, 254
- analytic function, 40
- angles in complex analysis, 21
- annuli,
 - conformal equivalence of, 208
 - conformal mapping of, 208
- annulus of convergence, 121
 - of a Laurent series, 121
- annulus, Cauchy integral formula for, 122
- argument, 21
 - of a complex number, 25
 - principle, 168, 170–172
 - principle for meromorphic functions, 172, 173
- arguments and multiplication, 25
- associative law, 15
- associativity
 - of addition, 1
 - of multiplication, 1
- behavior near an isolated singularity, 116
- biholomorphic, 193
 - mappings of the plane, 194
- boundary
 - maximum and minimum principles for harmonic functions, 255
 - maximum modulus theorem, 185
 - minimum modulus principle, 186
 - minimum principle, 255
 - uniqueness for harmonic functions, 256
- Cantor's set theory, 309
- Casorati-Weierstrass theorem, 117, 127
- Cauchy
 - estimates, 94
 - integral defining a holomorphic function, 88
 - integral formula, 79
 - integral formula for an annulus, 122
 - integral formula, general form, 82
 - integral formula on a disc, 81
 - integral formula, variants of, 87
 - integral theorem, 71, 74, 79
 - integral theorem, general form, 73
 - integral theorem, proof of, 71
 - product of series, 267

- Cauchy-Riemann equations, 32, 33, 36
 - in terms of complex derivatives, 35
- Cauchy-Schwarz inequality, 27
- Cayley
 - map and generalized circles, 204
 - transform, 203
- C^∞ functions, 32
- circulation of a fluid flow, 230
- cis notation, 20
- C^k functions, 32
- closed set, 10
- coefficients of a Laurent expansion
 - calculating, 131
 - formula for, 125
- commutative law, 15
- commutativity
 - of addition, 1
 - multiplication, 1
- compact set, 98
- complex
 - conjugate, 6
 - derivative, 34, 38, 62
 - derivative and holomorphic functions, 40
 - derivatives and complex coordinates, 34
 - derivatives in polar coordinates, 35
 - differentiability, 61
 - line integral, 54
 - line integral of any continuous function, 54
 - line integral, parametrizations for, 57
 - logarithm, 66
 - number system, 1
 - number, additive inverse for, 12
 - number, argument, 25
 - number, conjugate, 6
 - number, imaginary part, 5
 - number, modulus, 8
 - number, polar form of, 19
 - number, polar representation, 20
 - number, real part, 5
 - number, roots of, 4, 22
 - numbers, addition, 3
 - numbers, algebraic operations, 1
 - numbers as a field, 12
 - numbers, distance in, 8
 - numbers, multiplication, 3
 - numbers, multiplicative inverse for, 12
 - numbers, notation for, 5
 - numbers, standard form, 3
 - numbers, standard notation for, 2
 - numbers, topology of, 10
 - numbers, vector operations on, 5
 - potential, 236
 - roots, sketch of, 24
- compound Gauss-Jacobi quadrature, 245
- computer algebra systems, 319
- conformal, 40, 61, 62, 193
 - mapping, 40, 62, 193
 - mapping and partial differential equations, 225
 - mapping, determination of by boundary points, 240
 - mapping, numerical techniques, 239

- mapping of annuli, 208
- mappings, applications of, 225
- mappings, compendium of, 211
- mappings, explicit examples, 212
- mappings, list of, 225
- mappings of the plane, 194
- mapping to a polygon, 240
- self-mappings of the extended plane, 200
- self-maps of the disc, 196, 197
- self-maps of the plane, 194
- conformality, 61–62
 - characterization of holomorphicity in terms of, 62
- conjugate holomorphic function, 85
- connected set, 10, 107
- continuity
 - definitions of, 178
 - topological definition of, 178
- continuously differentiable function, 31, 52
- convergence of a power series, 100
- convex hull, 174
- cosine function, 18
- counterclockwise orientation, 51
- curve, 51
 - closed, 51
 - continuously differentiable, 53
 - image of, 51
 - parametrized, 51
 - simple, closed, 51
- deformability
 - of curves, 75
 - principle, 77
- deleted neighborhood, 115
- derivatives of a holomorphic function, 93
- differential equation
 - and the Fourier transform, 284
 - and the Laplace transform, 288
 - solution using Fourier series, 273
- differentiated power series, convergence of, 100
- directional derivatives, 34
- Dirichlet
 - problem, 226, 258
 - problem and conformal mapping, 226
 - problem on a general disc, 260
 - problem on a general disc, solution of, 260
 - problem on the disc, 258, 297, 301
 - problem on the disc, solution of, 259, 260
 - problem, physical motivation for, 226
- Dirichlet's definition of convergence of series, 309
- disc
 - biholomorphic self-mappings of, 197
 - closed, 10
 - conformal self-maps of, 196
 - Möbius transformations of, 197
 - of convergence of a power series, 100, 103
 - open, 10
 - rotations of, 196
- discrete set, 108, 161
- distributive law, 15
- domain, 12, 184
 - of convergence of a Laurent series, 122
- indistinguishable from the point

- of view of complex analysis, 193
 - with one hole, 208, 209
- doubly
 - connected domains, characterization of, 209
 - infinite series, convergence of, 121
 - infinite series, negative part, 121
 - infinite series, positive part, 121
- eigenfunction, 307, 308
- electrostatic
 - potential and the Dirichlet problem, 227
- electrostatics
 - and conformal mapping, 234
 - on a disc, 234
- entire function, 96
- essential singularities in terms of Laurent series, 126
- essential singularity, 117, 163
 - at infinity, 163, 164
- Euclidean algorithm, 97
- Euler
 - equidimensional equation, 298
 - formula, 17, 18, 37, 42
- exponential function, 18
 - definition of, 17
- exponentiation, laws of, 19
- extended complex plane, 201
- extended plane, 164, 201
 - topology of, 200
- factorial notation, 17
- field, 15
- finite wave train, 279
 - Fourier analysis of, 279
- fluid flow around a post, 235
- Fourier coefficients, 264
 - calculation of, 266
 - calculation of using complex analysis, 266, 267
- Fourier
 - cosine series, 307
 - inversion formula, 275
 - methods in the theory of differential equations, 295
 - notation, applied math version, 296
 - notations, various, 295
 - series, 263, 264
 - series and heat diffusion, 270
 - series and steady state heat distribution, 268, 274
 - series and the derivative of a function, 270
 - series, convergence of, 264, 265
 - series of the derivative function, 272
 - series on intervals of arbitrary length, 265
 - series, partial sums, 264
 - series, pointwise convergence of, 264
 - series, uniqueness of, 272
 - sine series, 307
 - transform, 274
 - transform and complex variables, 275
 - transform, definition of, 274
 - transform variable, 274
- function that can be expressed in terms of z only, 33
- functional analysis, 309
- functions with multiple singulari-

- ties, 135
- Fundamental Theorem
 - of Algebra, 3, 4, 15, 97, 182
 - of Calculus, 53
 - of Calculus along curves, 54
- $f(z)$, 320
- Gauss-Jacobi quadrature, 245
- Gaussian quadrature, 245
- generalized circles, 203
- Green's theorem, 72, 73, 230
- harmonic conjugate, 47
 - and Cauchy-Riemann equations, 48
 - nonexistence of, 47
- harmonic function, 45, 250
 - as the real part of a holomorphic function, 250, 251
 - definition of, 250
 - real- and complex-valued, 250
 - smoothness of, 251
- harmonicity of real and imaginary parts, 46
- heat diffusion, 226
 - and the Dirichlet problem, 226
- heat distribution, 226, 300
 - and conformal mapping, 232
 - on the disc, 300
- holomorphic function, 33, 31, 36, 38
 - alternative terminology for, 40
 - and polynomials, 31
 - and the complex derivative, 39
 - by way of partial differential equations, 31
 - counting the zeros of, 167
 - definition of, 36
 - derivatives of, 94
 - examples of, 36
 - is infinitely differentiable, 82
 - preimages of, 178
 - in terms of derivatives, 34
 - local geometric behavior of, 167
 - local geometry of, 176
 - on a punctured domain, 115
 - vs. harmonic functions, 91
 - with isolated singularities, 126
- homeomorphism, 201, 206
- homotopic to zero, 87
- Hurwitz's theorem, 182
- i , definition of, 2
- image of curve, 51
- imaginary part of a complex-valued function, 32
- incompressible fluid flow
 - and conformal mapping, 235
 - and the Dirichlet problem, 229
 - with a circular obstacle, 236
- indefinite integrals
 - calculation of, 146, 149, 150, 153, 155
 - summary chart of, 157
- independence of parametrization, 57
- index, 139
 - as an integer-valued function, 139
 - notation for, 139
 - of a curve with respect to a point, 139
- inequalities, fundamental, 25
- infinitely differentiable functions, 32
- integrals
 - calculation of using residues, 146
 - inequalities for, 57

- on curves, 53
 - properties of, 56
- inverse Fourier transform operator, 275
- isolated
 - point, 161
 - singular point, 115
 - singularities, 115
 - singularity, three types of, 116
- Jacobian matrix, 62
- Lagrange's formula, 175
- Laplace
 - equation, 45, 249, 297, 299
 - operator, 45, 226
 - transform, 287
 - transform, definition of, 287
 - transform, key properties of, 287
 - transform, usefulness of, 287
- Laplacian, 45, 250
- Laurent expansion
 - about ∞ , 163
 - existence of, 122, 123
 - uniqueness of, 122
- Laurent
 - polynomial, 129
 - series, 120
 - series, convergence of, 121
 - series, summary chart of, 141
- lens-shaped region, 232
- limit of a sequence of holomorphic functions, 98
- linear fractional transformation, 199, 202
 - and the point at infinity, 200
 - summary chart of, 204
 - utility of, 202
- lines as generalized circles, 203
- Liouville's theorem, 96
 - generalization of, 97
- location of
 - poles, 173
 - zeros, 170
- logarithm, 21, 66
 - and argument, 67
 - and powers, 68
 - as inverse to exponential, 67
- many-to-one holomorphic function, 178
- Maple, 319, 328
- MatLab, 4, 319, 330
- Mathematica, 319, 321
- maximum modulus principle, 184
 - for harmonic functions, 254
- mean value property, 303
 - for harmonic functions, 253
 - implies maximum principle, 254
- meromorphic
 - at ∞ , 163, 164
 - function, 161
 - functions as quotients of holomorphic functions, 162
 - functions, examples of, 162
 - functions in the extended plane, 164
 - functions with infinitely many poles, 162
- midpoint rule for numerical integration, 244
- minimum
 - modulus principle, 185
 - principle for harmonic functions, 254
- Möbius transformation, 188, 197

- monogenic function, 40
- Morera's theorem, 72
- multiple singularities, 161
- multiplicative identity, 2
- multiplicity of a root, 98
- Newton
 - Cotes formula, 245
 - method, 242
- nonrepeating decimal expansions, 1
- north pole, 201
- numerical
 - approximation of a conformal mapping onto a smoothly bounded domain, 245
 - integration techniques, 244
 - techniques, 239
 - techniques in conformal mapping, 239
- odd extension of a function, 307
- open mapping, 178
 - principle, 177
 - principle and argument principle, 177
 - theorem, 176
- open set, 10
- orthogonal matrix, 62
- orthogonality condition, 308
- path-connected set, 10
- path independence, 231
- phase variable, 274
- Picard's Great Theorem, 127
- piecewise
 - C^k curve, 73
 - differentiable function, 265
- planar domains, classification of, 209
- plane, conformal self-maps of, 195
- point at infinity, 202
- Poisson
 - integral formula, 257, 302, 303
 - integral kernel, 257, 258, 303
- polar form of a complex number, 19
- pole, 117, 163
 - at infinity, 163
 - graph of, 118
 - in terms of Laurent series, 126
 - location of, 173
 - of order k , 141
 - source of terminology, 127
- polynomial
 - characterization of, 97, 194
 - factorization of, 97
- population growth and the z -transform, 292
- potential function, 231, 239
- power series, 40, 100
 - and holomorphic functions, 101
 - differentiation of, 100
 - partial sums of, 100
 - representation, coefficients of, 101
 - representation of a holomorphic function, 99
 - table of, 104
- prevertices, 240
- preserving angles, 61
- principal
 - branch of the logarithm, 68
 - part of a function, 129
- principle
 - of persistence of functional relations, 111
 - of superposition, 306
- pseudodifferential operators, 309

- punctured domain, 115
- radius of convergence, 100
 - of a power series, 100
- rational
 - functions, characterization of, 164
 - number system, 1
- real
 - analyticity of harmonic functions, 251
 - numbers as a subfield of the complex numbers, 15
 - number system, 1
 - part of a complex-valued function, 32
- region, 12
- regular function, 40
- removable singularity, 163
 - at infinity, 163, 164
 - in terms of Laurent series, 126
- repeating decimal expansions, 1
- residue, 135, 137
 - calculus of, 135
 - concept of, 135
 - formula, 136, 137
 - method for calculating, 141
 - notation for, 137
 - summary chart of, 141
 - theorem, 136, 137, 140
- Ricci, 330
- Riemann
 - definition of the integral, 309
 - hypothesis, 388
 - mapping theorem, 206
 - mapping theorem, second formulation of, 206
- removable singularities theorem, 116–118
- sphere, 201
 - action of linear fractional transformation on, 202
 - conformal self-mappings of, 202
- right-turn angle, 240
- rotations, 196, 197
- Rouché's theorem, 180
 - and the Fundamental Theorem of Algebra, 182
 - and the winding number, 181
 - applications of, 181
 - variant of, 181
- scalar multiplication, 3
- Schwarz
 - Christoffel map, 212, 240, 242
 - Christoffel parameter problem, 242
 - lemma, 188
 - lemma, uniqueness in, 188
 - Pick lemma, 189
 - Pick lemma, uniqueness in, 189
- self-maps of the disc, 188
- separation of variables, 297, 298, 305
- set theory, 309
- simple
 - root, 98
 - zero, 168
- simply connected, 77, 206
- Simpson's rule for numerical integration, 244
- sine function, 18
- singular set, 161
- singularities

- at infinity, 162
- classification of, 116
- classification of in terms of Laurent series, 126
- sinks of fluid flow, 230
- sources and sinks for a fluid flow, 231
- sources of fluid flow, 230
- space variable, 274
- special orthogonal matrix, 62
- split cylinder, 227
- square root of -1 , 4
- steady state heat distribution, 232, 268, 300
- stereographic projection, 201
- stream function, 236, 239
- streamlines of a fluid flow, 236
- stretching equally in all directions, 61, 62
- Sturm-Liouville theory, 308
- symbol manipulation software, 319
- Table of
 - Laplace transforms, 289
 - Maple Commands, 329
 - Mathematica Commands, 329
- transform theory, 263
- trapezoid rule for numerical integration, 244
- triangle inequality, 9, 25
- trigonometric functions, 37
- uniform
 - convergence, 98
 - limit of holomorphic functions, 98
- unique continuation for holomorphic functions, 108
- uniqueness of analytic continuation, 110
- value β to order n , 169
- vibrating string, 304
- wave equation, 304
 - initial conditions for, 305
- wavelets, 309
- winding number, 139
 - as an integer-valued function, 139
 - of image curve, 172
- zero
 - location of, 167
 - multiplicity of, 168
 - of order n , 168
 - of a holomorphic function, 108
 - of a holomorphic function, counting, 170
 - of a holomorphic function, locating, 167
 - order of, 168
 - simple, 168
- zero set, 108
 - accumulating at boundary, 108
 - of a holomorphic function, 107, 108
 - discreteness of, 108
- z -transform, 291
 - and population growth, 292
 - definition of, 291

